

# X2 Truggy Set-up Sheet

Driver: \_\_\_\_\_

Track: \_\_\_\_\_ / \_\_\_\_\_

Air Temp: \_\_\_\_\_

Track Size      Traction      Surface

<input type="checkbox"/> open	<input type="checkbox"/> High	<input type="checkbox"/> Smooth
<input type="checkbox"/> Medium	<input type="checkbox"/> Medium	<input type="checkbox"/> Medium
<input type="checkbox"/> Tight	<input type="checkbox"/> Low	<input type="checkbox"/> Bumpy

## Front Suspension

Shock Spring: \_\_\_\_\_

Shock Piston:  Standard    Drilled

Shock Oil wt: \_\_\_\_\_

Shock Length  
(Center to Center) \_\_\_\_\_

Toe-IN:  \_\_\_\_\_

Toe-Out:  \_\_\_\_\_

Front Ride Height: \_\_\_\_\_ mm

Sway Bar:  2mm    2.3mm    2.5mm

Camber:  Neg: \_\_\_\_\_

Pos: \_\_\_\_\_

Caster Block:  A/A    B/B

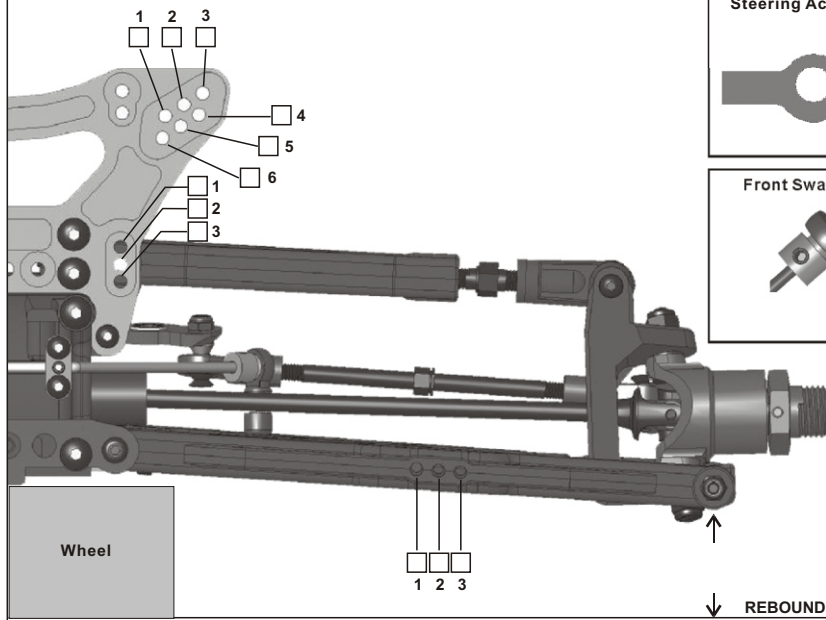
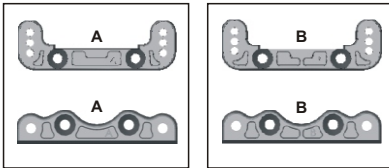

### Steering Ackerman Location



### Front Sway Bar Preload

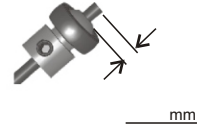

Notes: \_\_\_\_\_

## Rear Suspension

Shock Spring: \_\_\_\_\_

Shock Piston:  Standard    Drilled

Shock Oil wt: \_\_\_\_\_

Shock Length  
(Center to Center) \_\_\_\_\_

Rear Ride Height: \_\_\_\_\_ mm

Sway Bar:  2.3mm    2.5mm    2.8mm  
 \_\_\_\_\_    None

Camber:  Neg: \_\_\_\_\_

Pos: \_\_\_\_\_

Rear Hub/Wheelbase:  Forward    Middle  
 Back

### Rear Toe-In Plate

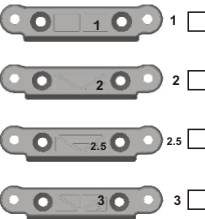

### Anti-Squat Plate

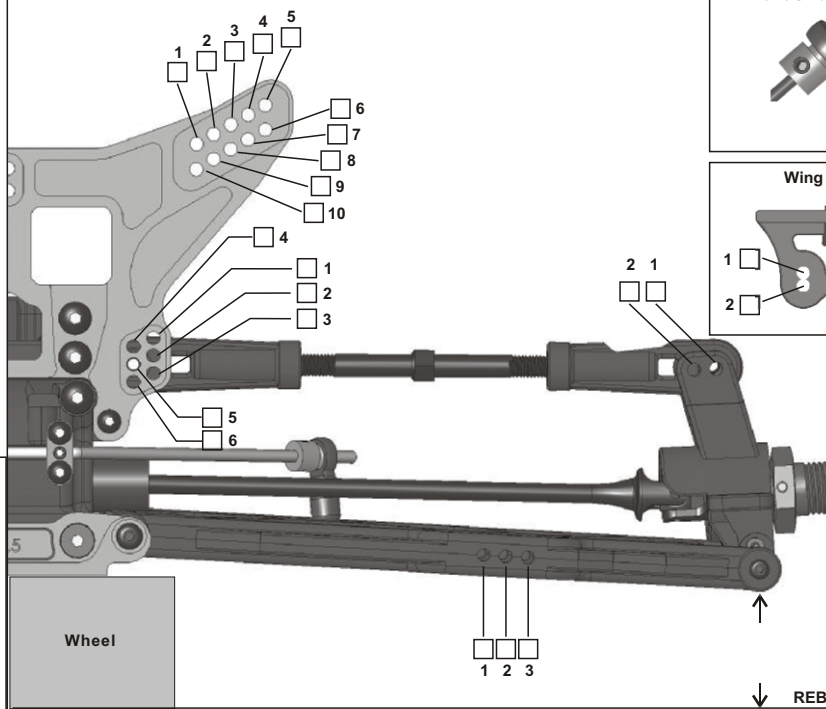
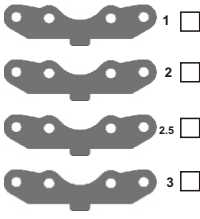

### Front Sway Bar Preload

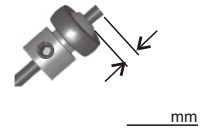

### Wing Position

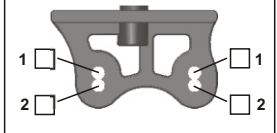

## Differential

Front Type:  STD    Torsen   Oil \_\_\_\_\_ K

Center Type:  STD    Torsen   Oil \_\_\_\_\_ K

Rear Type:  STD    Torsen   Oil \_\_\_\_\_ K

## Tires

Front Type: \_\_\_\_\_ Compound \_\_\_\_\_

Foam: \_\_\_\_\_

Rear Type: \_\_\_\_\_ Compound \_\_\_\_\_

Foam: \_\_\_\_\_

Note: \_\_\_\_\_

## Engine

Type: \_\_\_\_\_

Head Clearance \_\_\_\_\_ Port: \_\_\_\_\_

Pipe: \_\_\_\_\_

Fuel: \_\_\_\_\_ %

Plug \_\_\_\_\_  Turbo    Normal

## CLUTCH

Shoe Brand: \_\_\_\_\_ Compound: \_\_\_\_\_  ALUM:  Blue    Red

Spring Brand: \_\_\_\_\_ Tension \_\_\_\_\_

Gearing: \_\_\_\_\_ 13T \_\_\_\_\_ 14T   TO \_\_\_\_\_ 46T \_\_\_\_\_ 48T

Note: \_\_\_\_\_

### Clutch Shoes:

2 Shoes

3 Shoes

4 Shoes