

J-CONCEPTS BJ4 SET-UP SHEET:

DRIVER: _____

DATE: _____

TRACK/CITY: _____

EVENT: _____

NOTES:

CONDITIONS:

- SMOOTH: _____
- BUMPY: _____
- LOW TRACTION: _____
- MED TRACTION: _____
- HIGH TRACTION: _____
- WET: _____
- DRY: _____
- SANDY: _____
- SOFT DIRT: _____
- GRASS: _____
- BLUE GROOVE: _____
- CLAY: _____
- DUSTY: _____
- OTHER: _____

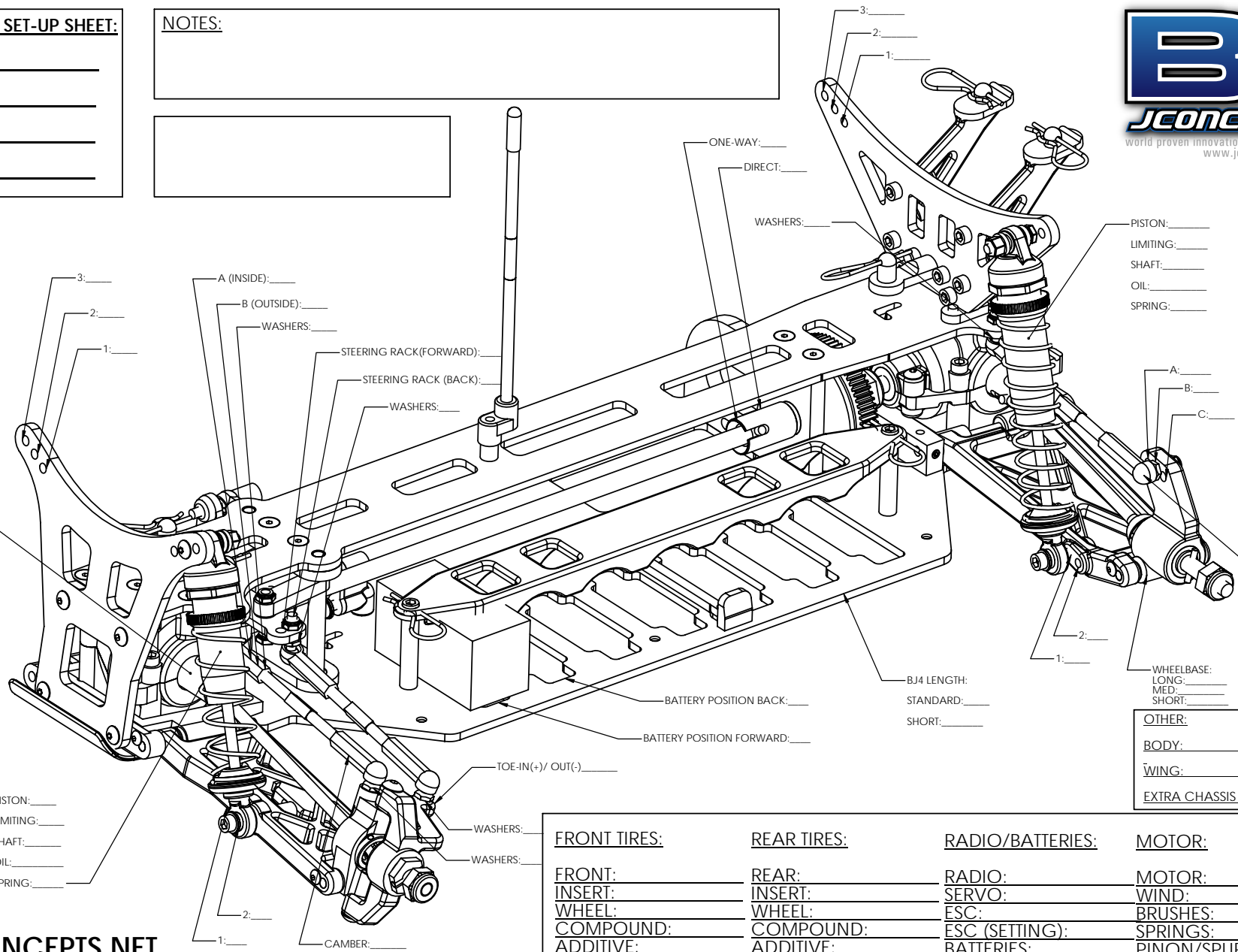

ONE-WAY: _____
DIFF: _____

PISTON: _____
LIMITING: _____
SHAFT: _____
OIL: _____
SPRING: _____

PISTON: _____
LIMITING: _____
SHAFT: _____
OIL: _____
SPRING: _____

A: _____
B: _____
C: _____

CAMBER: _____

WHEELBASE:
LONG: _____
MED: _____
SHORT: _____

OTHER: _____
BODY: _____
WING: _____
EXTRA CHASSIS WEIGHT: _____

FRONT TIRES:	REAR TIRES:	RADIO/BATTERIES:	MOTOR:
FRONT: _____	REAR: _____	RADIO: _____	MOTOR: _____
INSERT: _____	INSERT: _____	SERVO: _____	WIND: _____
WHEEL: _____	WHEEL: _____	ESC: _____	BRUSHES: _____
COMPOUND: _____	COMPOUND: _____	ESC (SETTING): _____	SPRINGS: _____
ADDITIVE: _____	ADDITIVE: _____	BATTERIES: _____	PINON/SPUR: _____