

ACADEMY

HOBBY MODEL KITS

# SB SPORT

1/10 SCALE EP 4WD OFF-ROAD BUGGY

CA709

1594

SB  
SPORT  
4WD

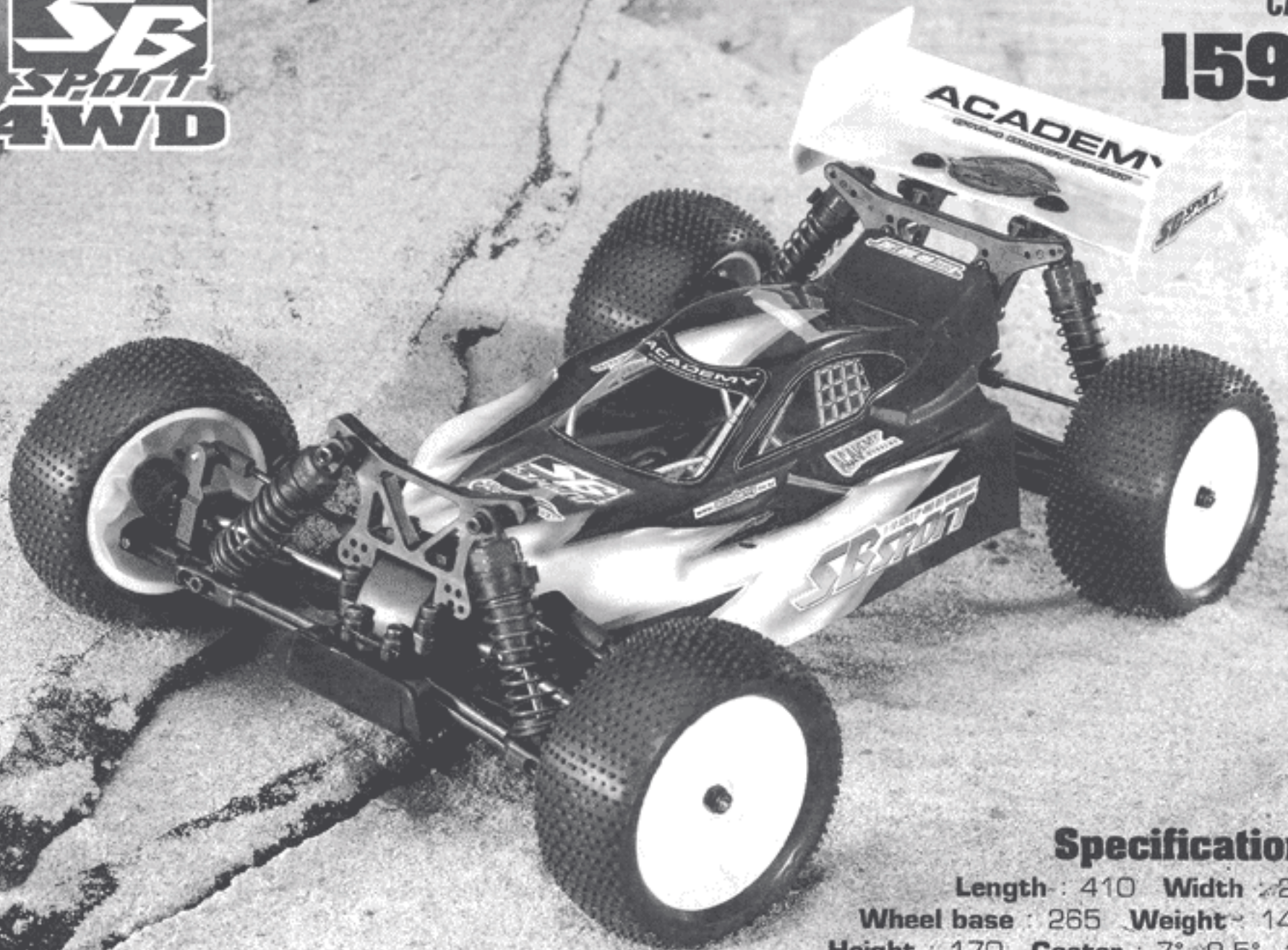

### Specifications

Length : 410    Width : 249  
Wheel base : 265    Weight : 1480  
Height : 170    Caster : 7°, 9.5°, 12°

## INSTRUCTION MANUAL

- Excellent maintenance and extensive Setting available
- Shaft Drive 4wheel Drive System    ○ One piece Black Epoxy Glass(FRP) Chassis
- AI Center Drive Shaft / Oil-filled type Damper    ○ 9×Ball Bearings
- Anti-vibration AI Die Casting Motor Mount
- 정비성이 우수하고 다양한 셋팅이 가능    ○ 샤프트 드라이브 4륜구동 시스템    ○ 원피스 블랙 에폭시 수지 세시 채용
- 알루미늄 센터 드라이브샤프트/오일    ○ 오일 주입식 댐퍼 채용    ○ 볼베어링 9개 사용
- 진동방지 모터 마운트 채용    ○ 유니버설 드라이브 샤프트(전륜) 채용

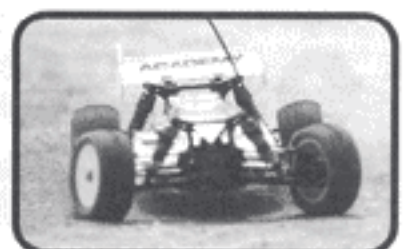
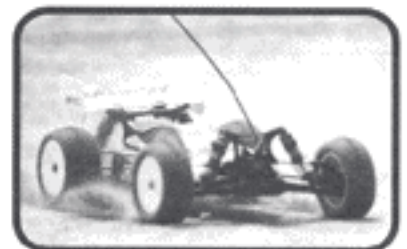

# R/C Equipment (키트 외에 준비 해야할 물품)

## ■ RADIO CONTROL UNIT

2채널 송수신기 세트

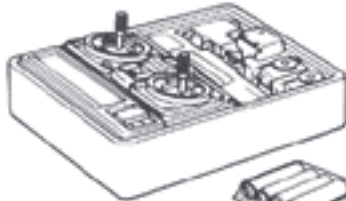

2 channel Radio Control unit  
2채널 송수신기 세트



Battery  
송수신기용 배터리  
(1.5V 8EA)

This kit is designed for a 2 channel 2 servo digital proportional type of radio control system.

Almost any 2 channel radio can be used. A unit can be used in other model.

본 키트에는 2채널 송수신기 세트를 이용한다. 어느 회사의 것이든 무방하며, 일단 1세트가 준비되면 여러가지 R/C 모형에 응용하여 사용할 수 있다.

## ■ BUGGY CAR BODY(Included)

버기카 바디(Kit에 포함)



## ■ 540 TYPE MOTOR

540타입 모터



## ■ Ni-Cd BATTERY

7.2V 충전배터리



Stick pack battery  
스틱팩 배터리

Straight pack battery  
스트레이트팩 배터리

It can be recharged more than 300times.  
니카드 배터리라고도 하며 충전하여 계속 사용(300회 정도) 할 수 있는 전지를 말한다.

## ■ ELECTRONIC SPEED CONTROLLER

전자변속기

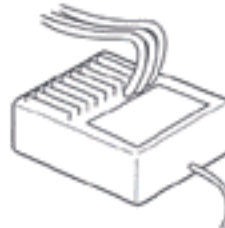

## ■ CHARGER for Ni-Cd Battery

Ni-Cd 배터리 전용 충전기



## ■ GLUE 접착제

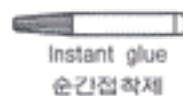

Instant glue  
순간접착제

## ■ TOOLS

조립에 필요한 공구



## ■ POLYCARBONATE PAINT

색칠에 필요한 재료



## ■ RC EQUIPMENT

송수신기의 동작시형

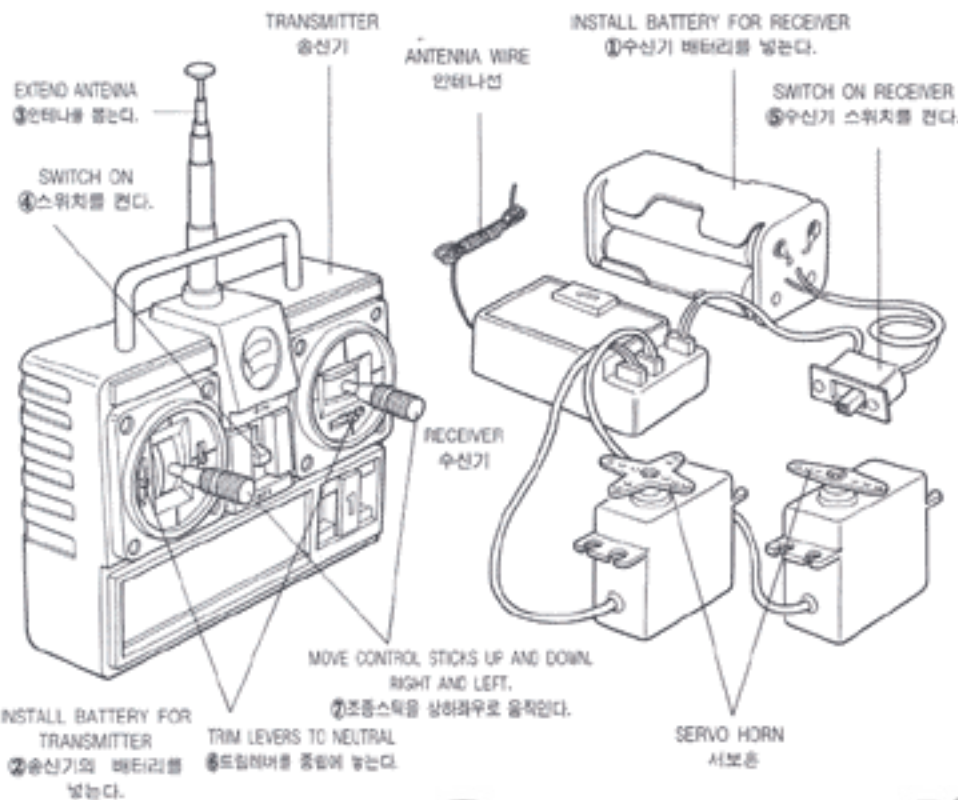

The digital proportional system comprises a transmitter, receiver, servos, etc.

- Transmitter - Servos as a control box. Stick movements are transformed into radio wave signals which are transmitted through antenna.
- Receiver - Receives signal from the transmitter.
- Servos - Servo transforms signals received by the receiver into mechanical movements and actuates the controlled portion of the car.
- Trim Lever - Trim Lever is used to change the direction of the front wheel or to control speed.
- Level Meter - Level Meter shows that batteries for the transmitter are playing out.
- Servo Horn - Servo Horn joints servo with the controlled portion of the car.

2채널 송수신기 세트는 송신기와 수신기, 서어보 및 배터리케이스로 구성되어 있다.

- 송신기 - 조종하는 콘트롤 박스로서 모터의 회전, 키의 좌우 움직임을 안테나를 거쳐 전파로 송신한다.
- 수신기 - 송신기로부터 전파를 받아서 서어보로 보낸다.
- 안테나 - 송신기의 안테나는 전파를 보내고 수신기의 안테나는 전파가 들어오는 중요한 것으로 최대한 길게 사용하는 것이 좋다.
- 트림레버 - 송신기의 트림레버는 서어보의 중심위치를 좌우로 조금씩 움직여 속도조정이나 키의 방향을 수정할 때 사용한다.
- 레벨미터 - 송신기의 전원이 소모된 정도를 나타내는 눈금으로 송수신기의 전원이 약할 경우 잘못된 동작을 하는 경우가 있으니 항상 주의한다.
- 서어보용 - 서어보와 차의 콘트롤부분을 연결하는 것으로써 여러종류가 있으므로 사용 목적에 맞는 형태를 사용한다.

## ■ 부품을 조립하기전에

- 구입 후 조립하기 전에는 반드시 부품도와 대조 확인하고 결함 부품이나 부족한 부품이 있을 경우에는 구입처에 연락하여 교환하거나 환불을 받으십시오.
- 조립을 시작한 후에는 반쯤이나 교란을 사정합니다. 작은 비스, 너트 등은 모양이 비슷하므로 실명서를 잘 읽어 본 후 조립한다.
- 송수신기 및 서어보에 종이 들어갔을 경우 모공수리가 되지 않으니 취급에 주의한다. ● 한 가지씩 조립을 확실히 해나가는 것이 고장을 막고 완성도를 충분히 발휘하는 좋은 R/C모형이 된다.
- Before assembling a kit, please be sure to check the parts up with its parts list. ● Small screws and nuts look alike and read instructions very well before assembling.
- To make a good R/C model of high-performance but less trouble, it needs to make the correct and steady assembling step by step.

※ Do not use excessive force when tightening the tapping screws and bolts. 볼트 및 비스를 질 때 너무 무리하게 힘을 가하지 않는다.

Cut away 잘라낸다	Use allen key, ⊕wrench. L자 또는 ⊕자렌치를 사용하여 조립한다.	Repeat operation 수 만큼 조립한다	Repeat for opposite side 반대측도 조립한다.	Apply grease to the place. 그리스를 바른다
Optional parts 선택한다	Make hole 구멍을 뚫어준다.	Be careful 주의한다.	Apply instant glue to the place. 순간접착제를 바른다	

아카데미제품을 구입해 주셔서 감사합니다. 조립을 시작하기전에 설명서를 충분히 읽어 보아야 합니다. 작업도중 부상을 방지하기 위해 주의가 필요합니다.

Thank you for your purchase ACADEMY products. Be sure to read the instructions fully before starting the assembly. Cares should be taken to avoid any injuries during the works.

# 1 A

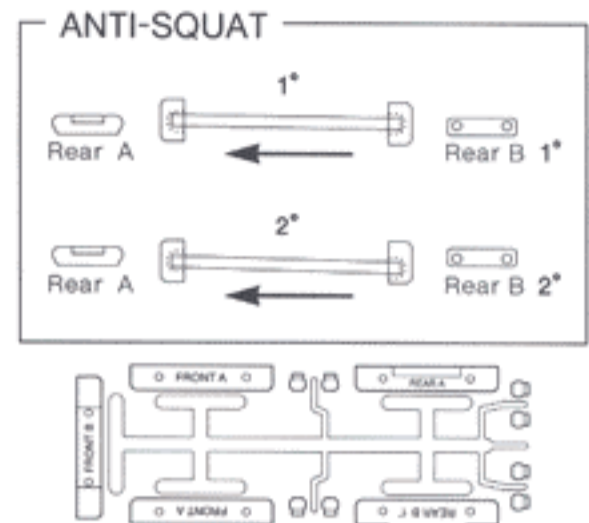
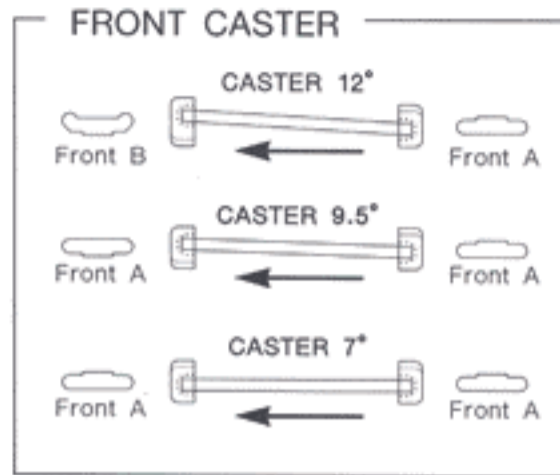
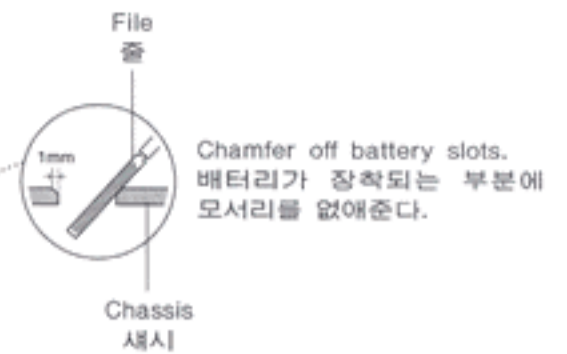

55mm Hinge pin 4  
힌지핀



3x12 F/H Screw 8  
접시볼트



3x6 Washer 8  
와셔

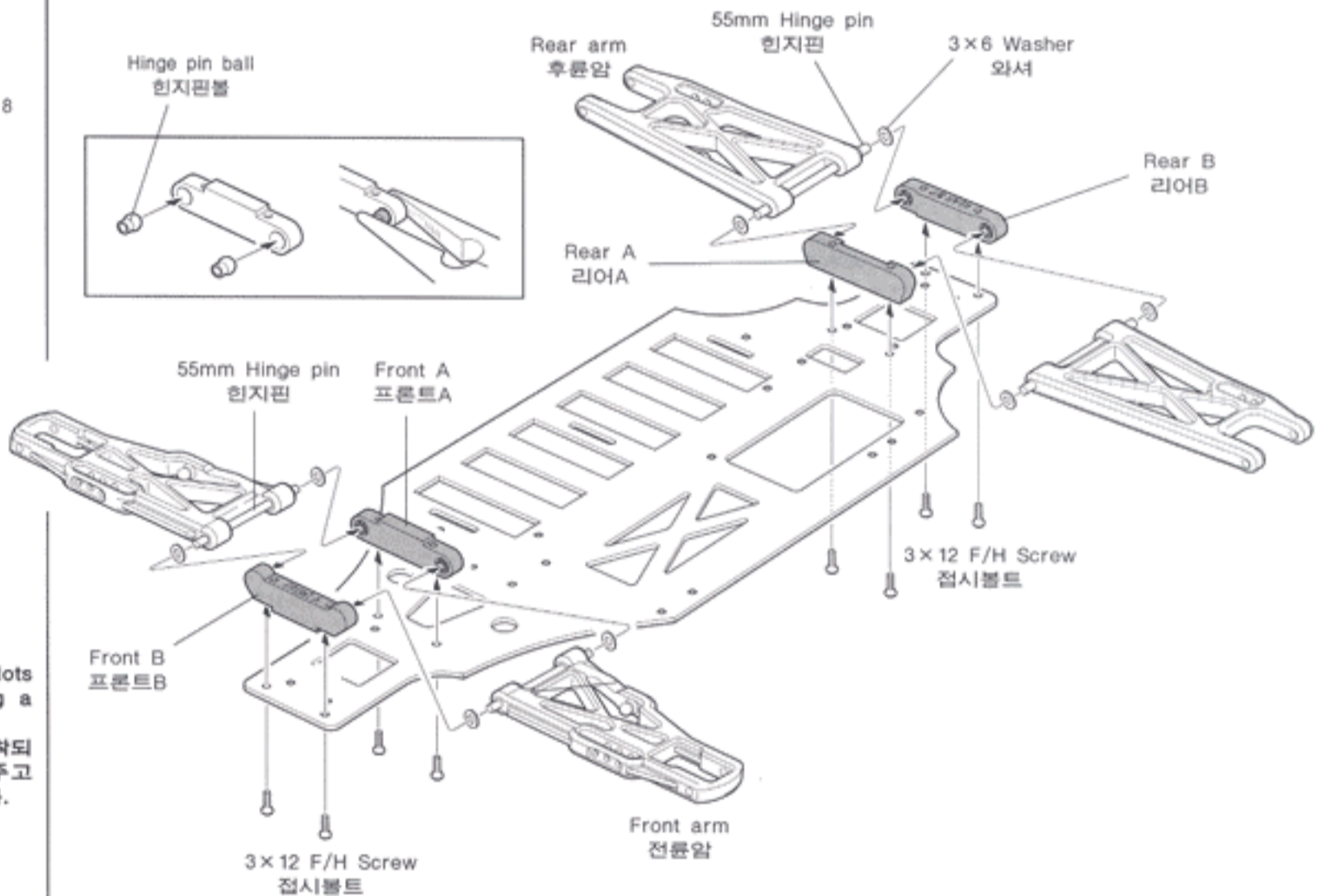
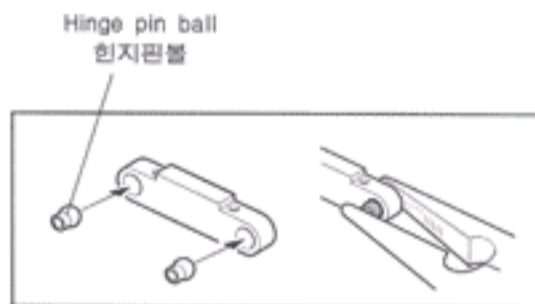

※ Chamfer edges of battery slots and remove any pips using a file.

줄을 사용하여 배터리가 장착되는 부분의 모서리는 없애주고 모든 가공 찌꺼기를 제거한다.





3x8 F/H Tapping screw 5  
비스

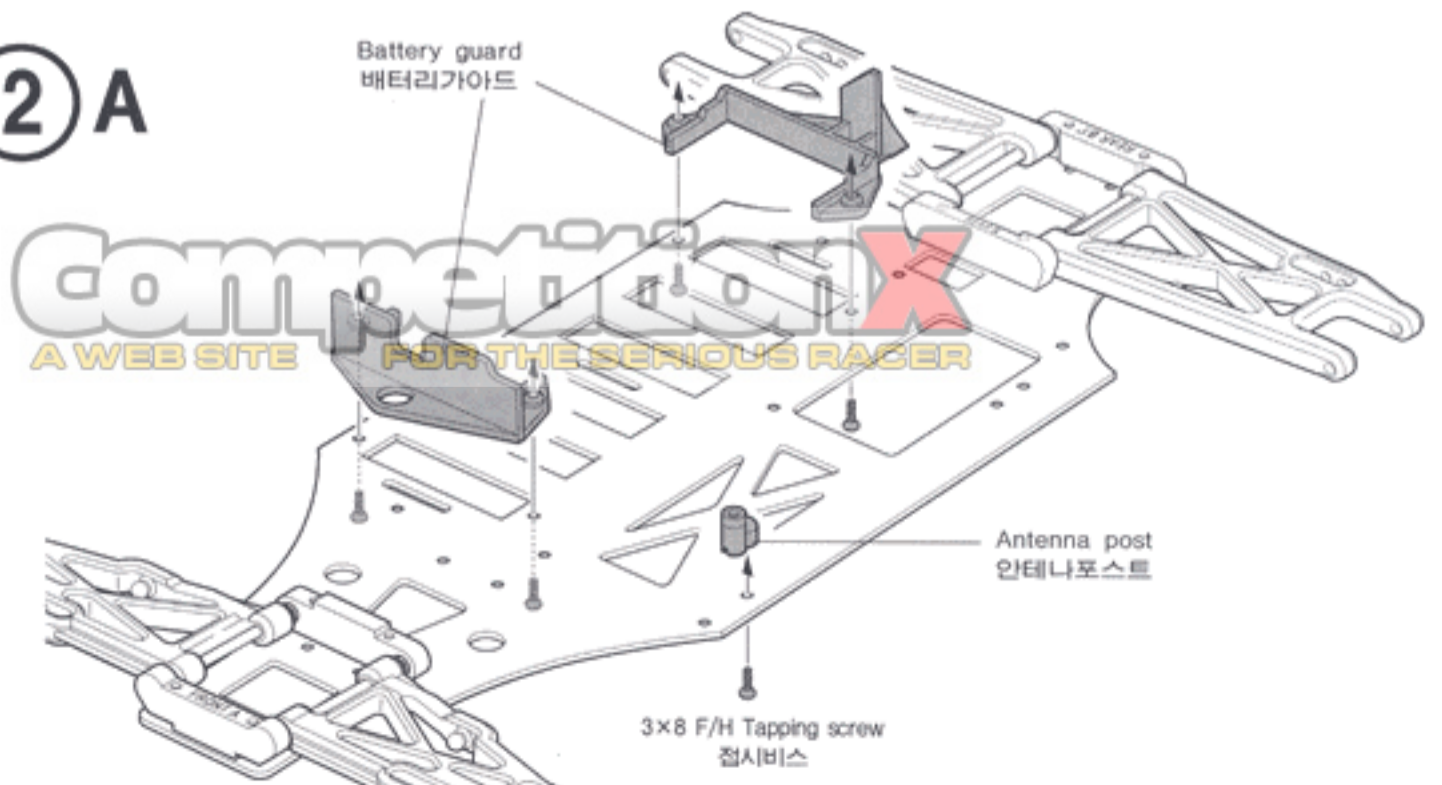





# 2 A



Competition X  
A WEB SITE FOR THE SERIOUS RACER

-  Ball diff. screw 2  
볼디프스크류
-  Ball diff. nut 2  
볼디프너트
-  850 Oilless metal bearing 4  
오일레스메탈 베어링
-  2x6 Thrust washer 4  
스러스트와셔
-  Ball diff. spring 2  
볼디프스프링
-  ø 2.5 Diff. ball 24  
디프볼
-  ø 2 Thrust ball 12  
스러스트볼

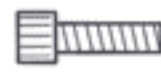
-  Ball diff. washer 4  
볼디프와셔
-  10x13x0.2t Washer 3  
와셔

-  Front bevel gear shaft 1  
전륜베벨기어샤프트
-  ø 1.5x7.5 Pin 1  
핀
-  C-Stop ring 1  
스톱링
-  Center joint cup 1  
센터조인트컵
-  4x4 Set screw 1  
육각렌치볼트
-  3x10 Cap screw 2  
캡스크류
-  1510 Ball bearing 2  
볼베어링
-  1050 Ball bearing 2  
볼베어링

### 3 B 2

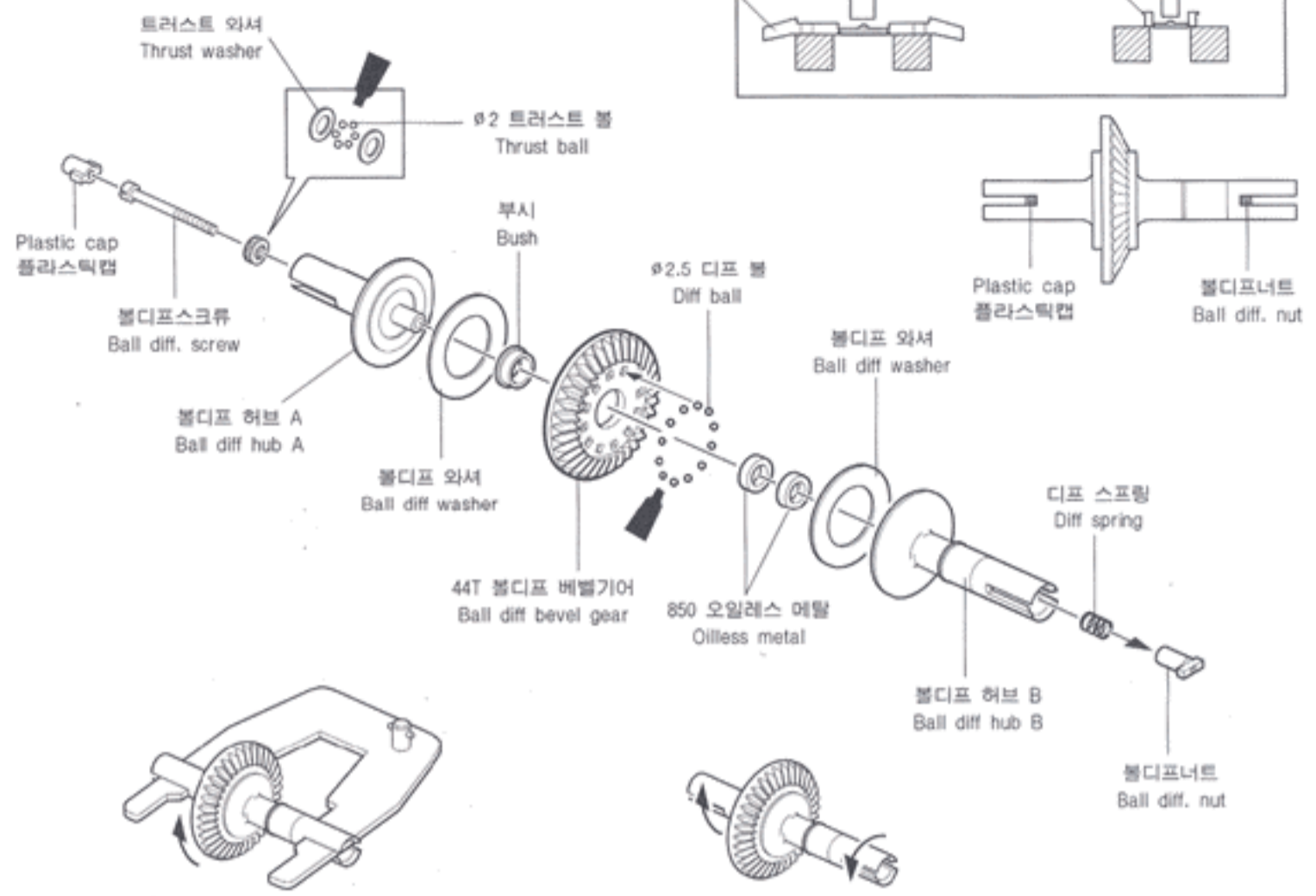

그림과 같이 양쪽의 디프허브를 고정시키고 디프기어가 슬립하지 않을 정도까지 볼디프스크류를 죄어본다. 너무 세게 죄지 말 것. 무리하게 죄면 디프와셔가 파손될 수 있다.  
As shown in picture, holding both of diff joint cups, tighten ball diff screw as much as it does not slip. Do not tighten too much, or diff washer can be damaged.

디프기어는 그림과 같이 부드럽게 움직이도록 조립한다. 볼디프스크류를 너무 세게 죄지 않도록 주의.  
The differential should spin smoothly after they are assembled. Take care not to tighten ball diff screw too much.

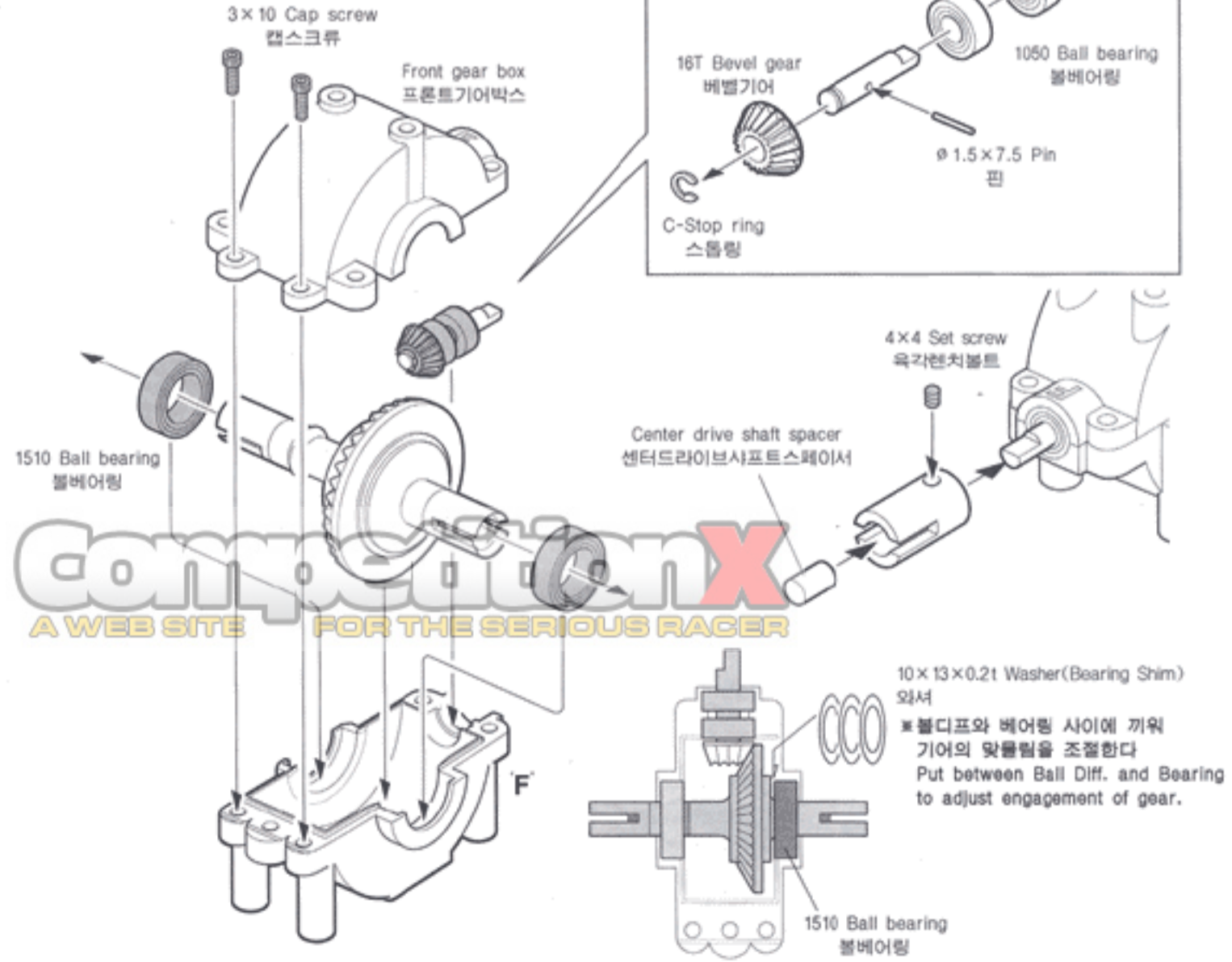

### 4 C



**Competition X**  
A WEB SITE FOR THE SERIOUS RACER



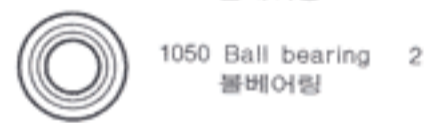

10x13x0.2t Washer (Bearing Shim) 와셔  
\* 볼디프와 베어링 사이에 끼워 기어의 맞물림을 조절한다  
Put between Ball Diff. and Bearing to adjust engagement of gear.

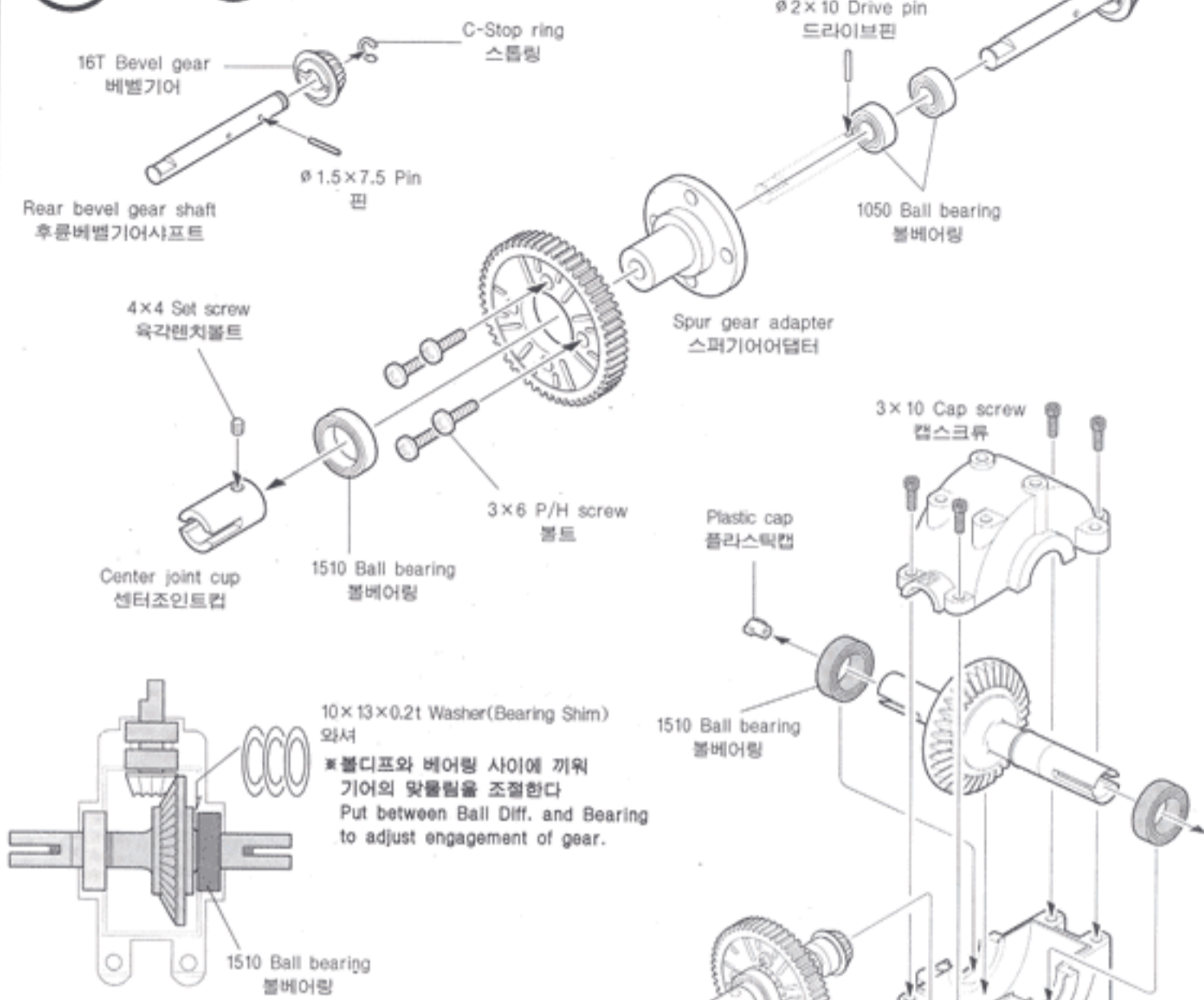
# 5 C

-  Rear bevel gear shaft 후륜베벨기어샤프트 1
-  Center joint cup 센터조인트컵 1
-   $\phi 1.5 \times 7.5$  Pin 핀 1
-   $\phi 2 \times 10$  Drive pin 드라이브핀 1
-  3 x 10 Cap screw 캡스크류 4
-  3 x 6 P/H screw 볼트 4
-  C-Stop ring 스톱링 1
-  4 x 4 Set screw 육각렌치볼트 1
-  1510 Ball bearing 볼베어링 3
-  1050 Ball bearing 볼베어링 2
-  10 x 13 x 0.2t Washer (Bearing Shim) 와셔 3



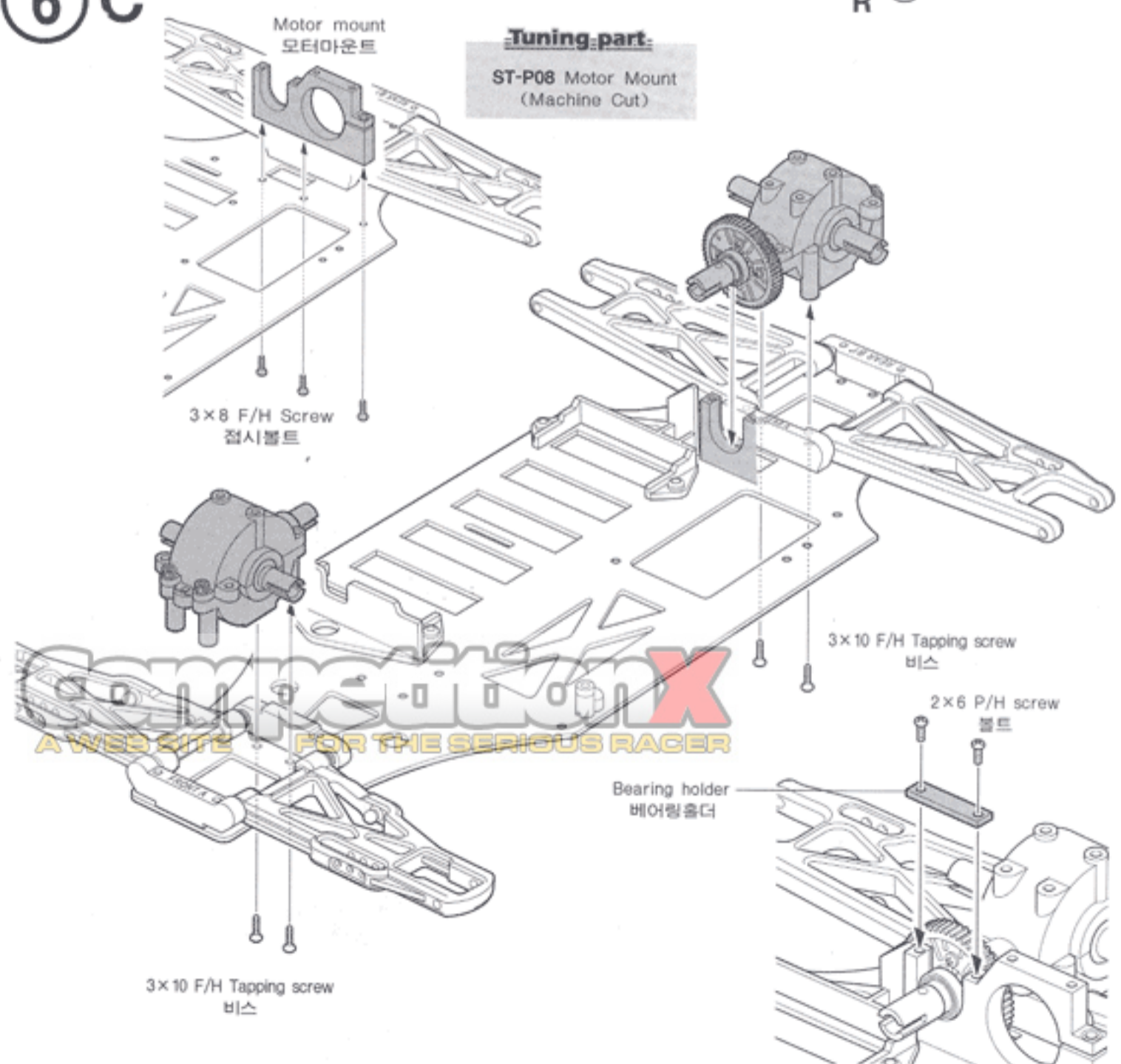

# 6 C

-  Plastic cap 플라스틱캡 1
-  Bearing holder 베어링홀더 1
-  3 x 8 F/H Screw 접시볼트 3
-  2 x 6 P/H screw 볼트 2
-  3 x 10 F/H Tapping screw 비스 4



**COMPETITION X**  
A WEB SITE FOR THE SERIOUS RACER

# 7 D

-   $\phi 2 \times 11$  Joint pin 4  
조인트핀
-   $\phi 4.5 \times 7.5$  Joint pin 4  
조인트핀
-   $3 \times 2.5$  Set screw 4  
육각렌치볼트

-   $\phi 4.3$  Pin ball 4  
핀볼

-  King pin 4  
킹핀

-  26.5mm Hinge pin 2  
힌지핀

-   $\phi 2$  E-Ring 4  
E-링

-  1510 Oilless metal 2  
오일레스메탈 베어링

-  1050 Oilless metal 2  
오일레스메탈 베어링

## Tuning part:

-  **K0603**  
1510 Ball bearing 2  
볼베어링
-  **WT-02**  
1050 Ball bearing 2  
볼베어링

## 2

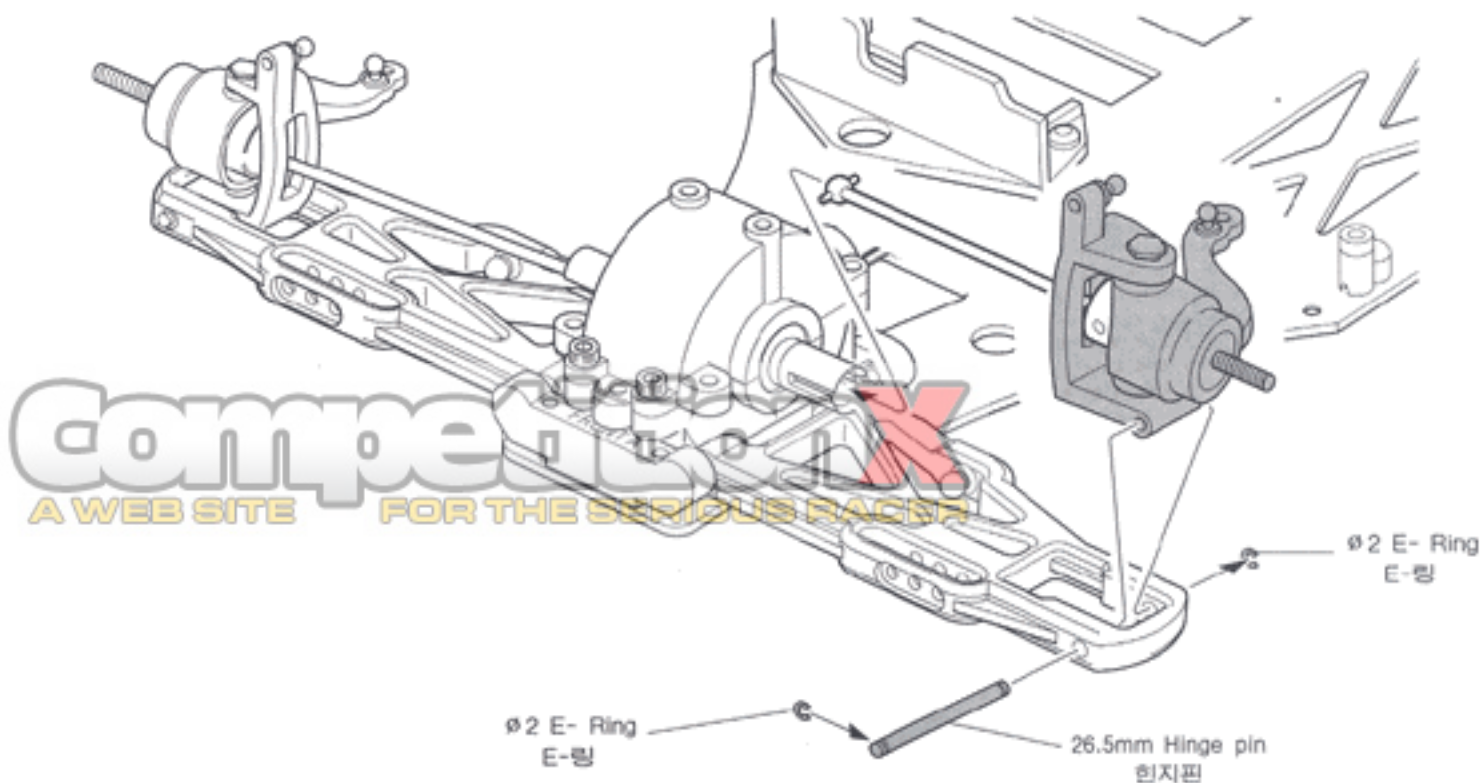
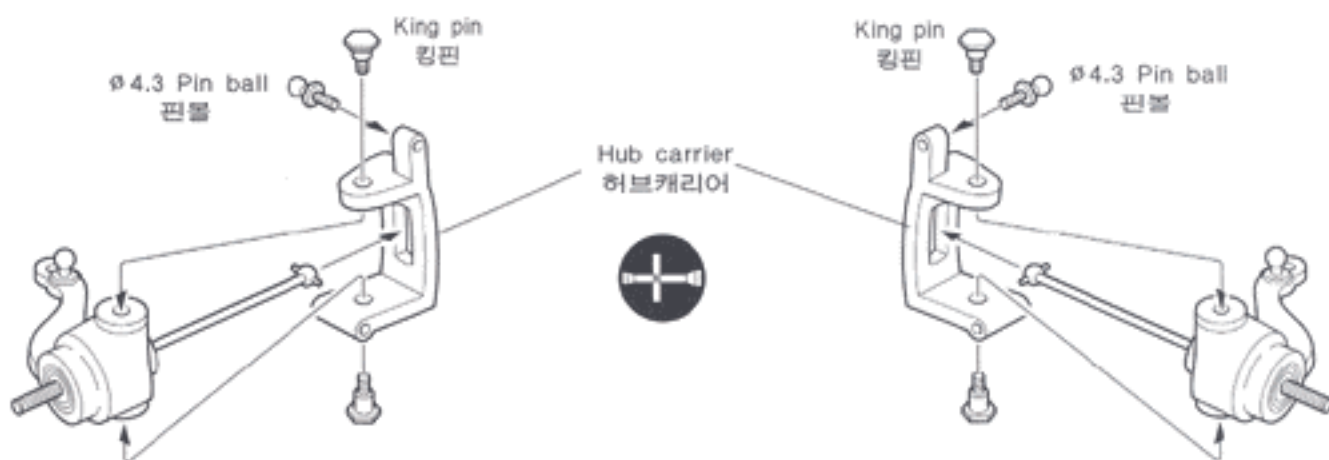
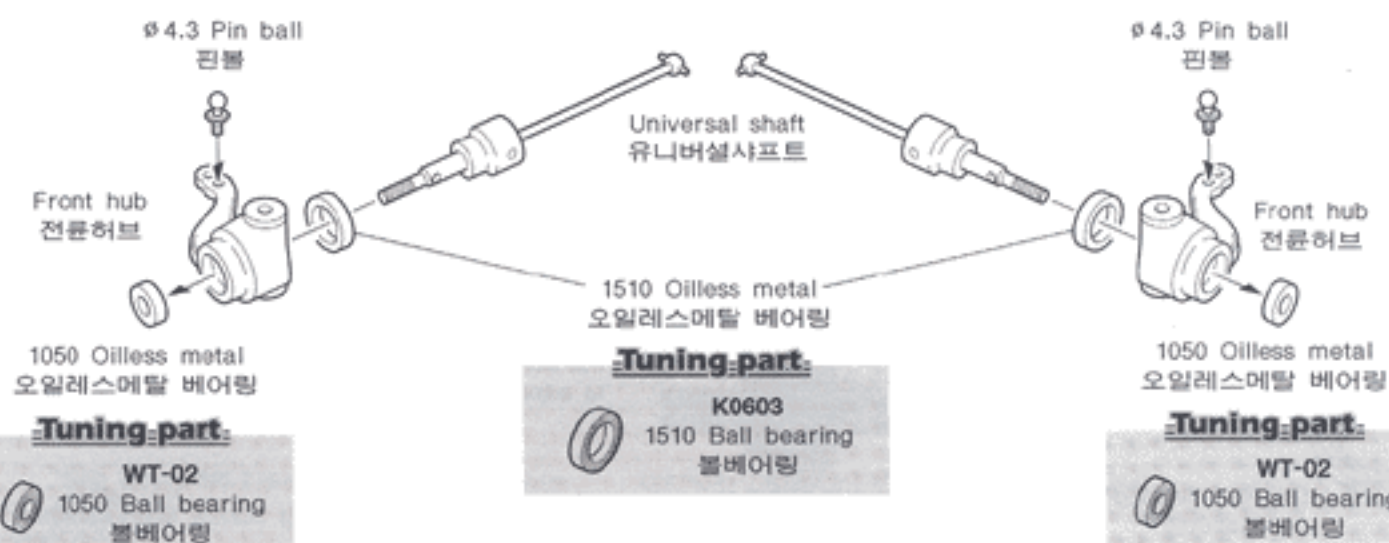
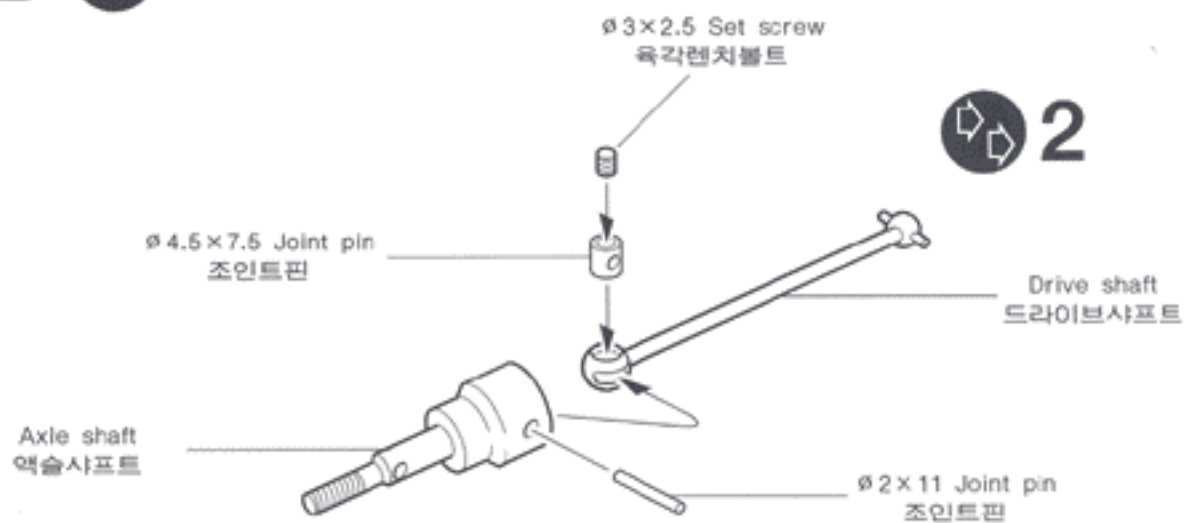

**Competition**  
A WEB SITE FOR THE SERIOUS RACER

# 8 D

  $\phi 4.3$  Pin ball 핀볼 2

 33mm Hinge pin 힌지핀 2

  $\phi 2$  E- Ring E-링 4

 1510 Oilless metal 오일레스메탈 베어링 2

 1050 Oilless metal 오일레스메탈 베어링 2

 Rear hub spacer 후륜허브스페이서 4

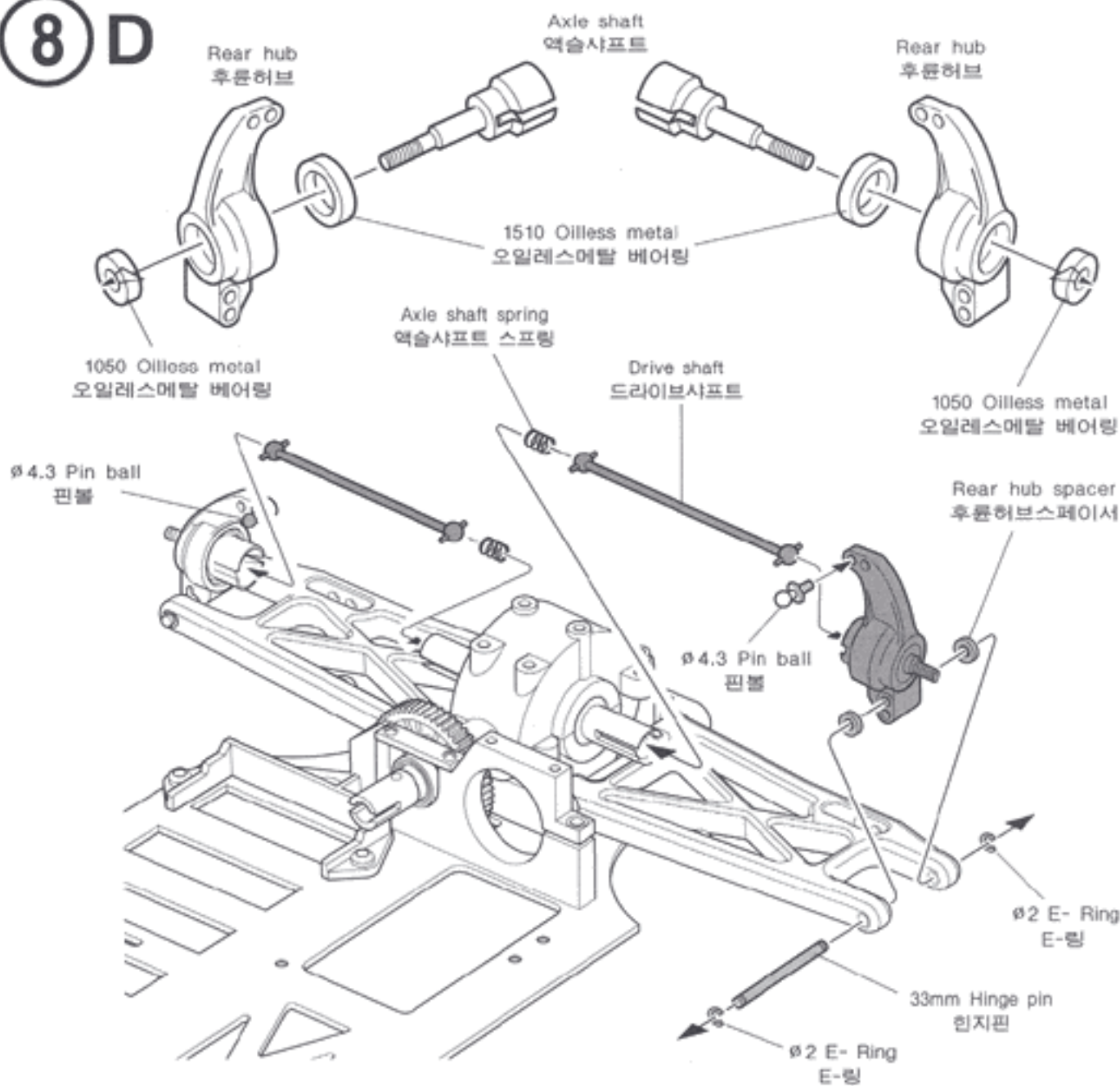

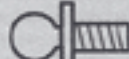

## Tuning part

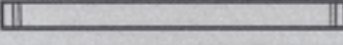
  $\phi 4.3$  Pin ball 핀볼 2

 33mm Hinge pin 힌지핀 2

  $\phi 2$  E- Ring E-링 4

 K0603 1510 Ball bearing 볼베어링 2

 WT-02 1050 Ball bearing 볼베어링 2

 Rear hub spacer 후륜허브스페이서 4

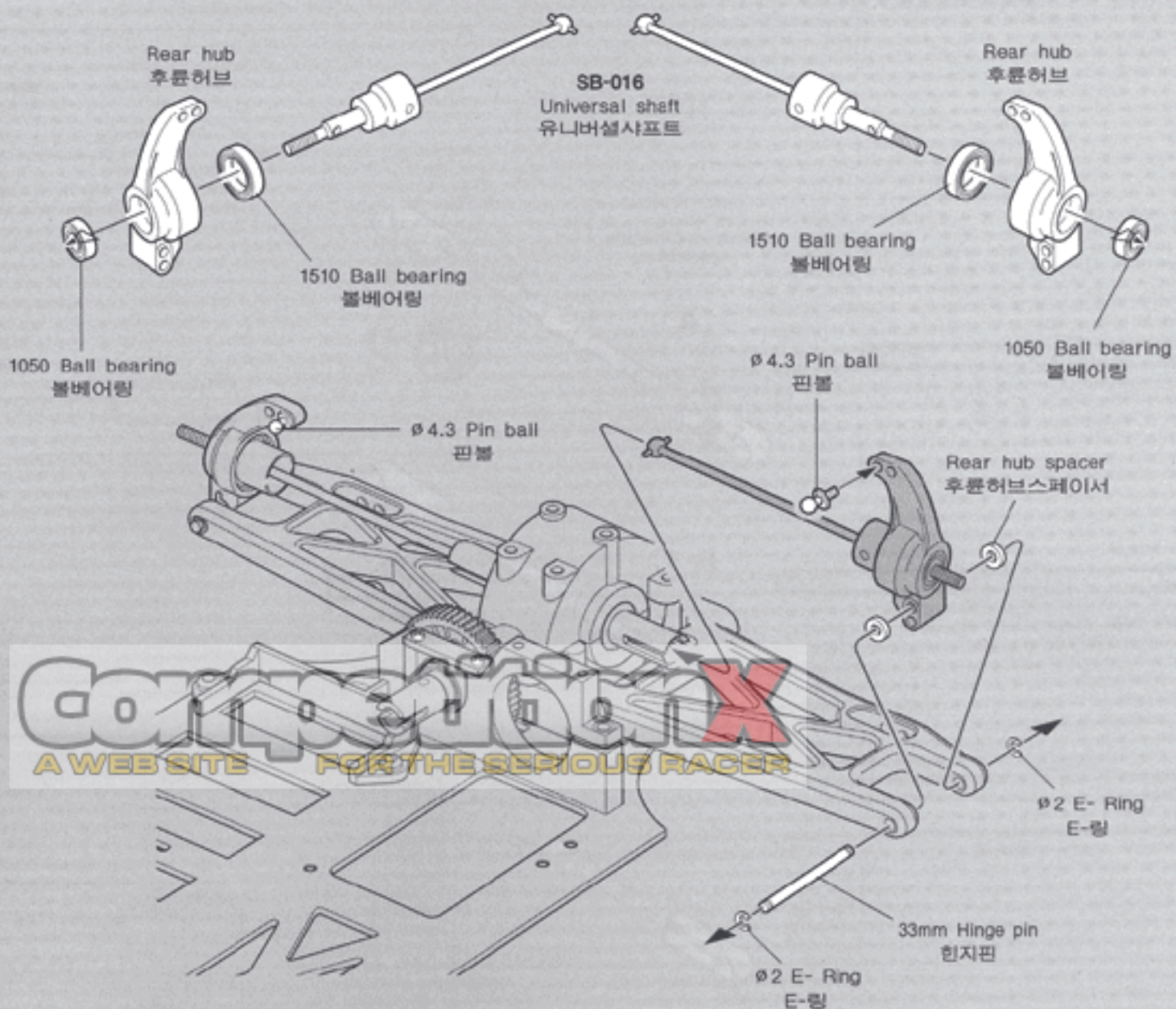

# 9 E

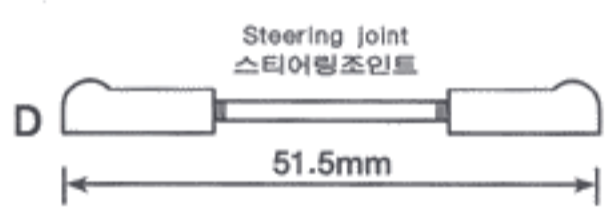
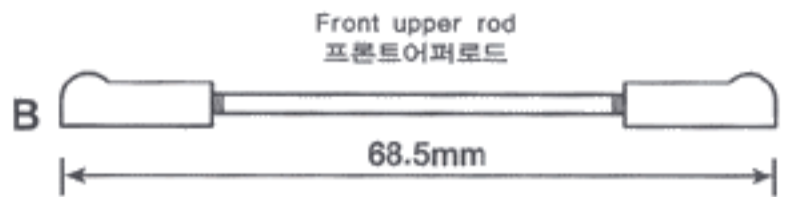
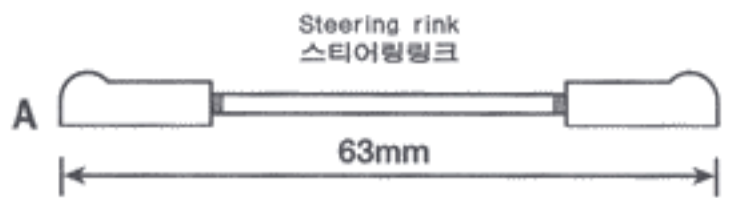
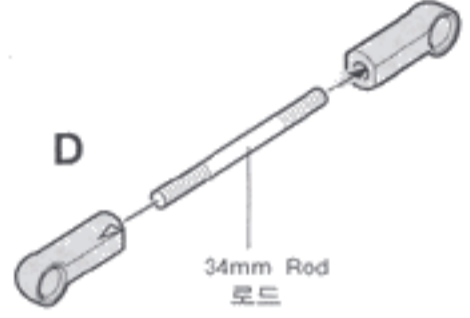
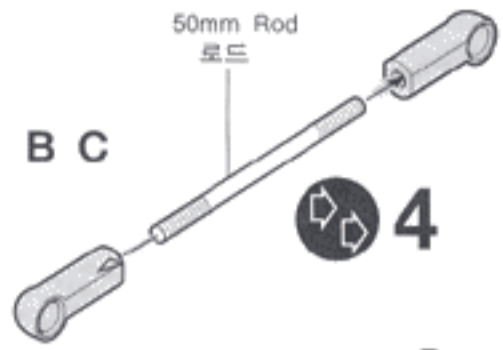
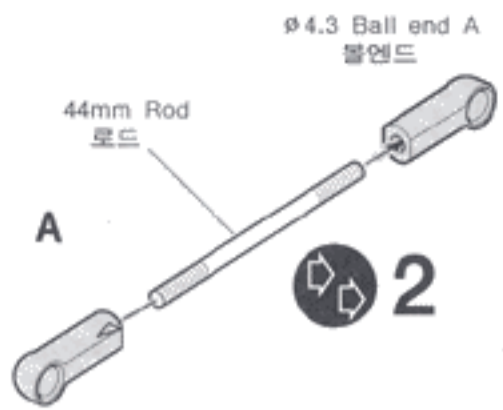
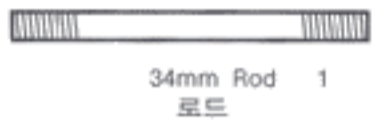
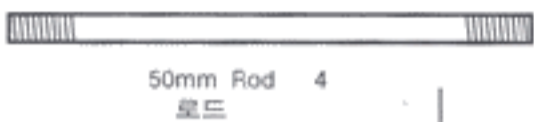

## Tuning part

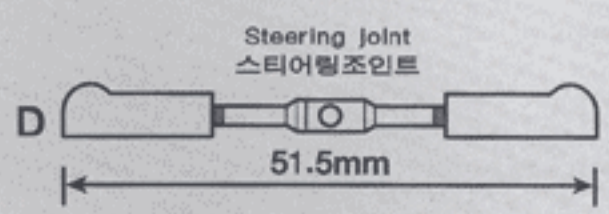
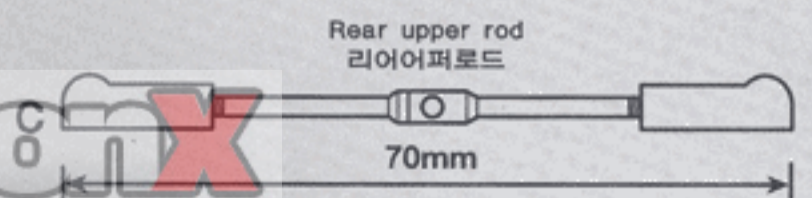
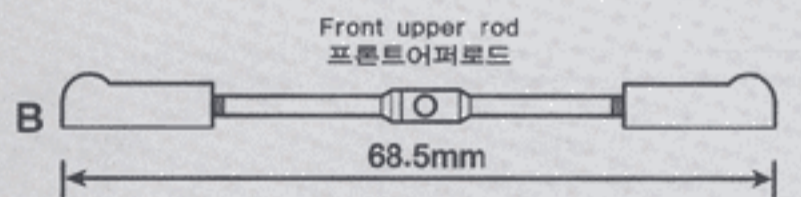
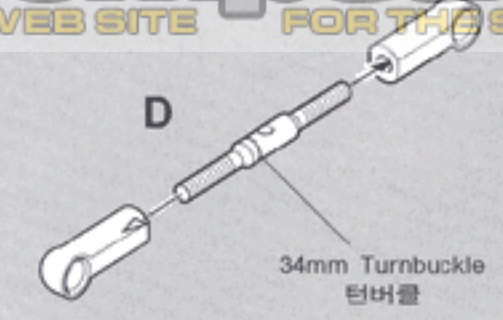
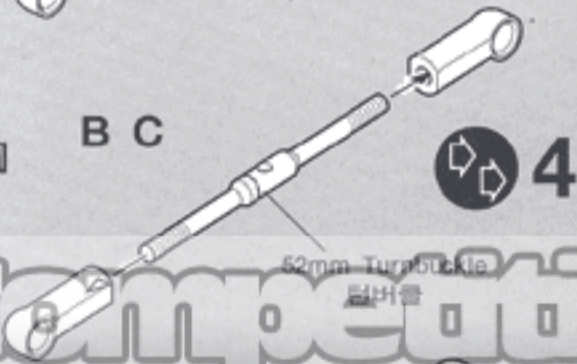
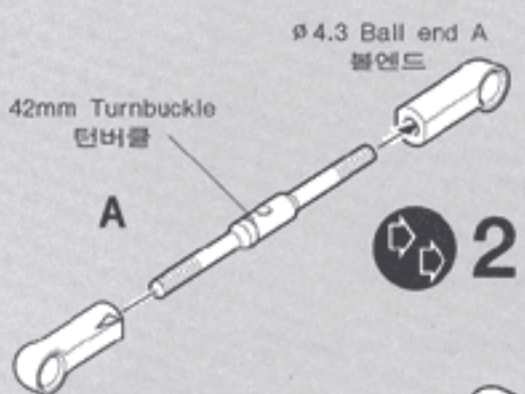
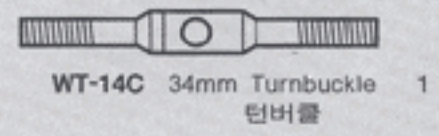
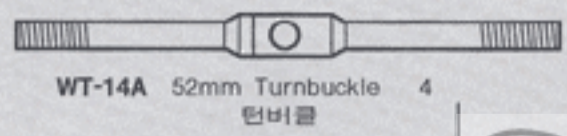

**Competition X**  
A WEB SITE FOR THE SERIOUS RACER



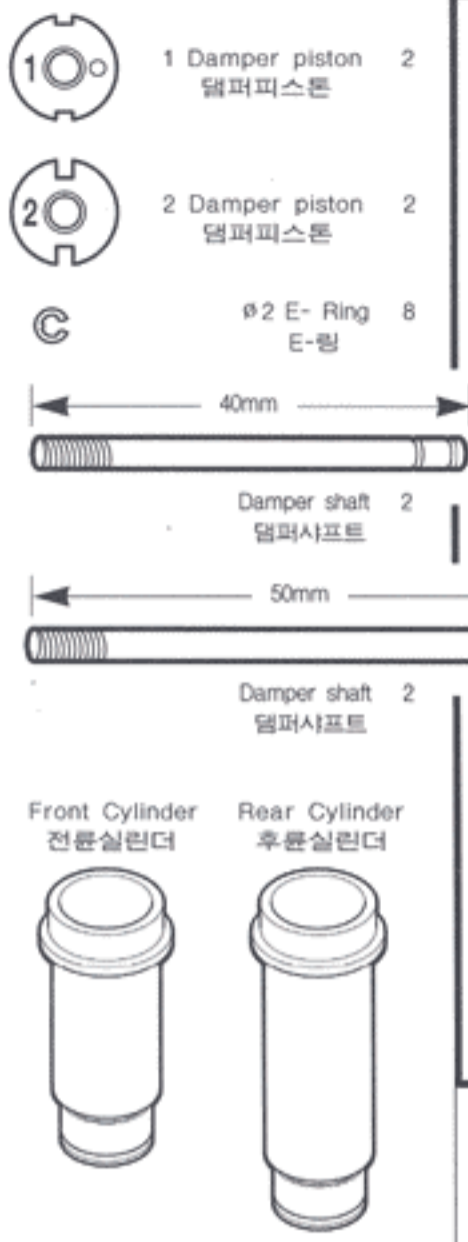

## Damper Exploded View <댐퍼분해도>

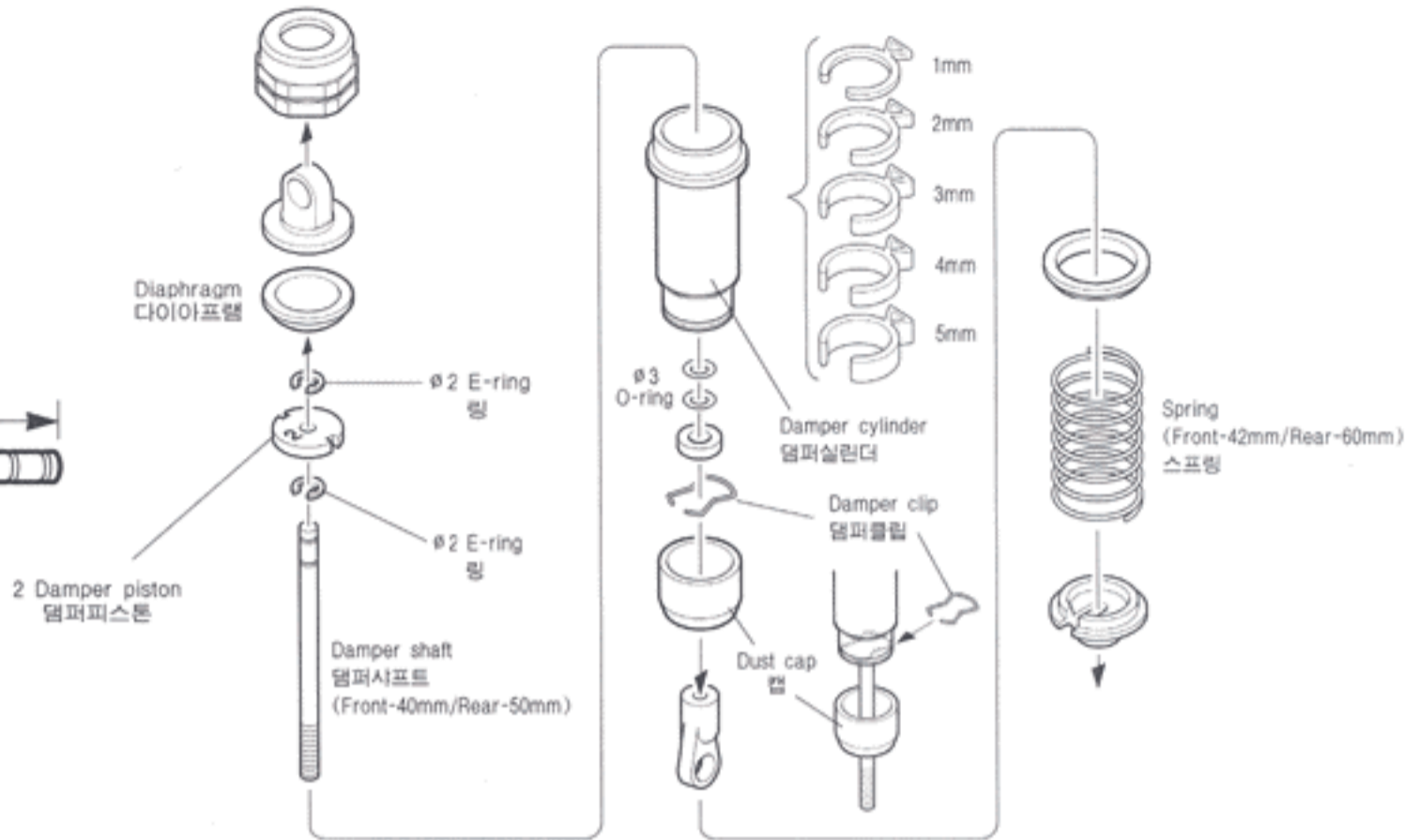

## 10 F 4

Put E-ring using a long nose plier as shown.  
그림과 같이 라디오벤치를 사용하여 E-링을 끼워 넣는다.



Use a pad to protect damper shaft.  
그림과 같이 볼렌드 조립시 미끄러지지 않는 고무패드로 감싼 후 라디오 벤치로 잡고 조인다.

**\* Notice**  
Scratches on damper shaft by tools can be a reason of drop in its efficiency.  
\*주의- 댐퍼샤프트에 벤치 등으로 인한 상처(흠집)가 나면 댐퍼의 기능이 떨어진다.

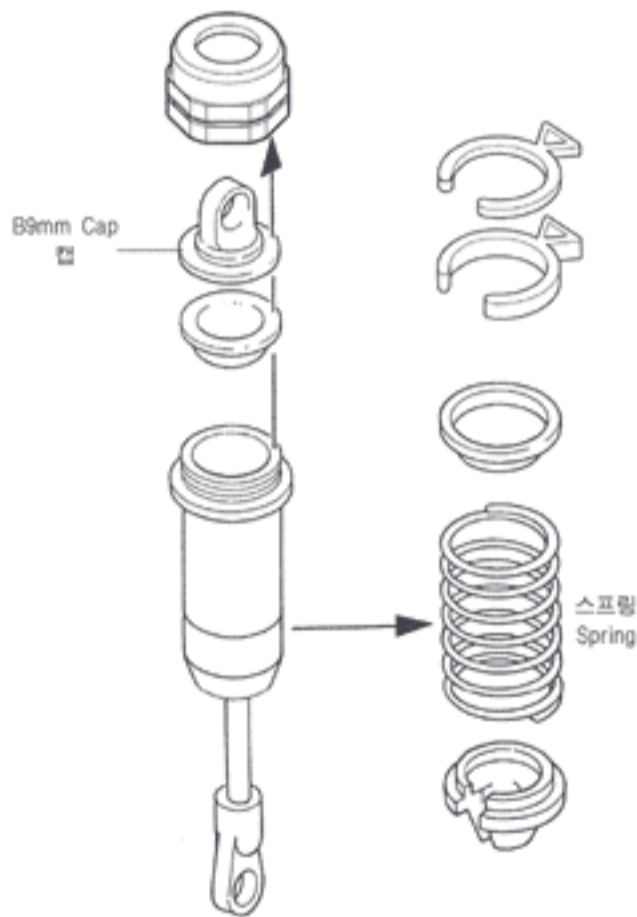



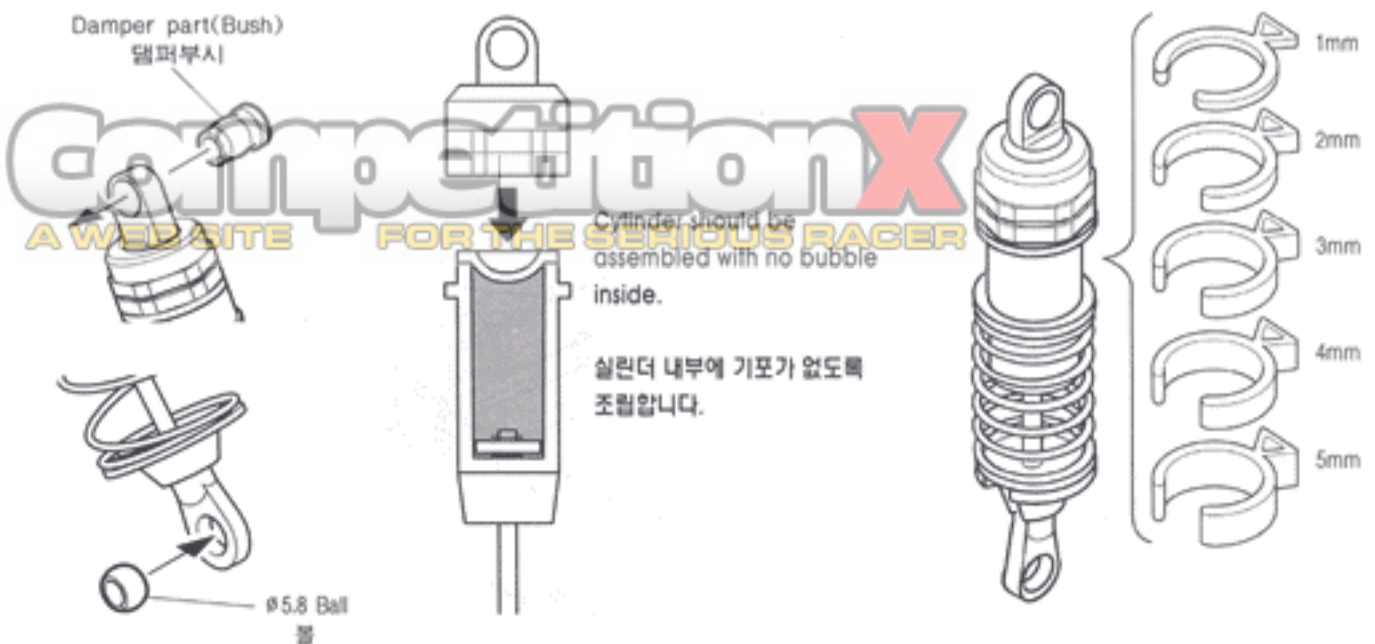

Fill up OIL into Cylinder, and remove bubbles by moving piston up and down.

실린더 속에 오일을 가득 채우고 피스톤을 위아래로 움직여 기포를 제거합니다.

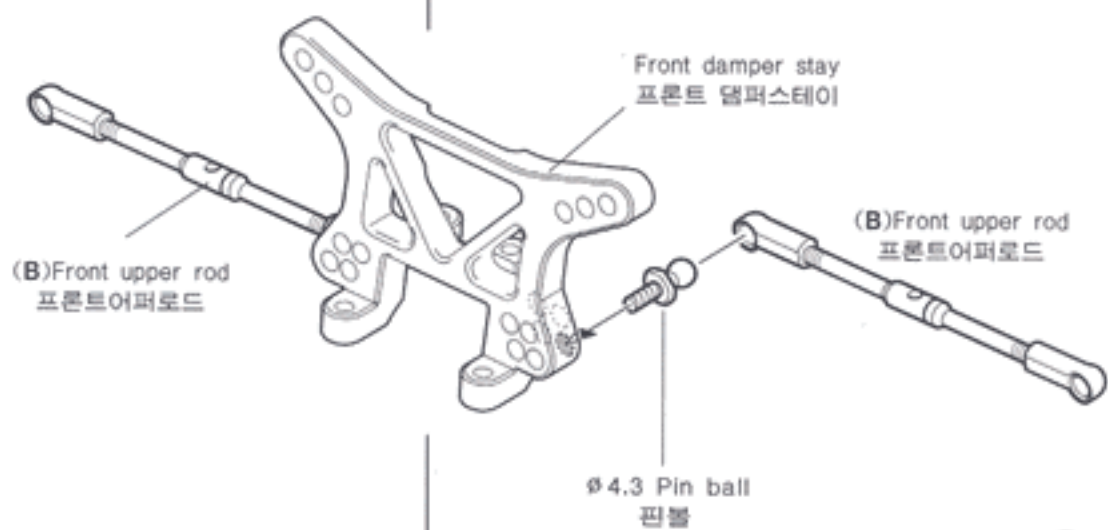

# 11 G



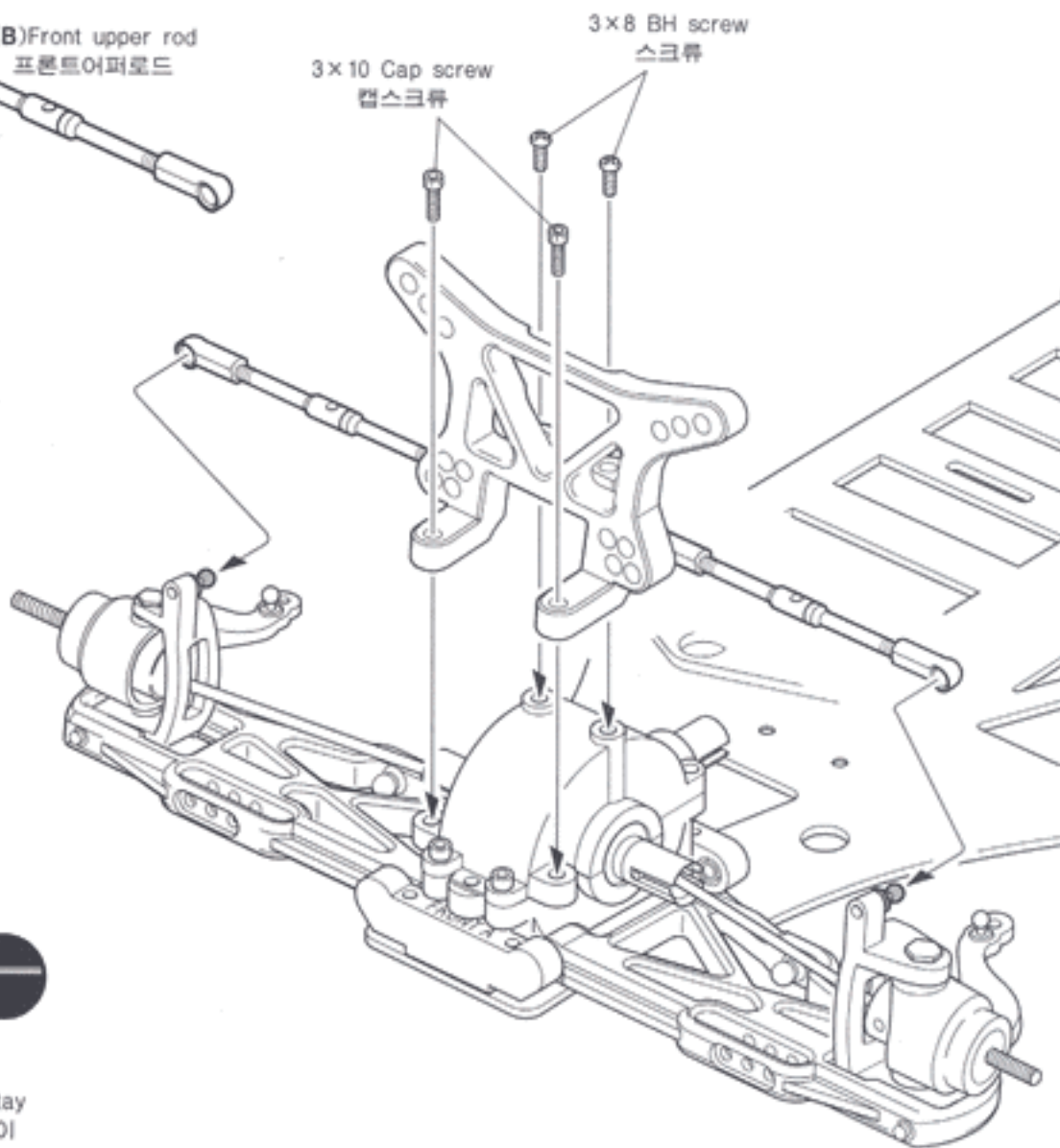

-  Ø 4.3 Pin ball 2  
핀볼
-  3x10 Cap screw 2  
캡스크류
-  3x8 B/H screw 2  
스크류

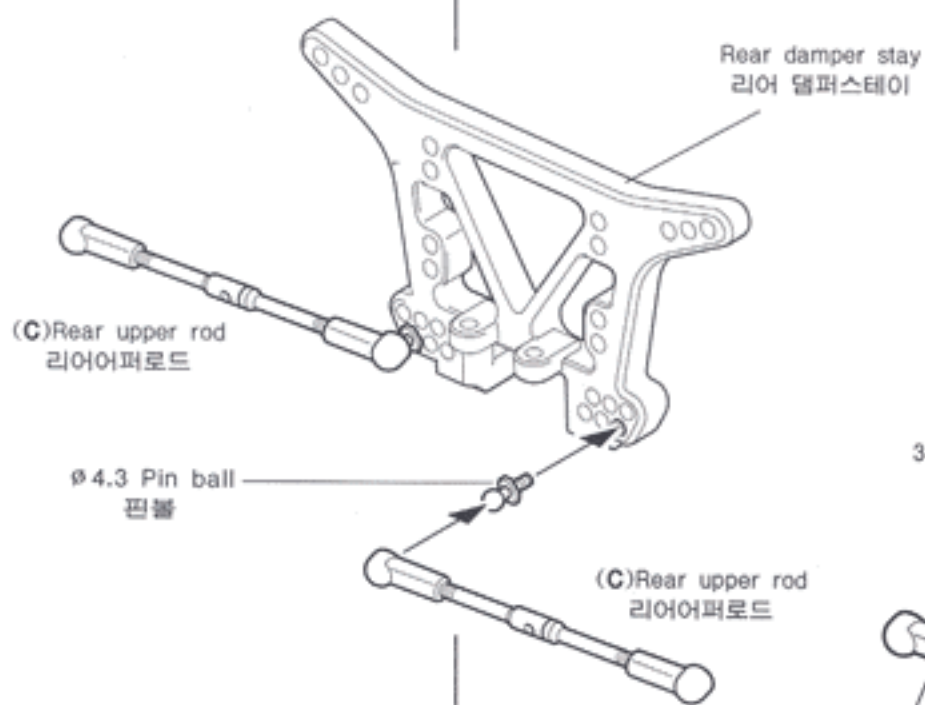

# 12 G



-  Ø 4.3 Pin ball 2  
핀볼
-  3x10 Cap screw 2  
캡스크류
-  3x8 B/H screw 2  
스크류

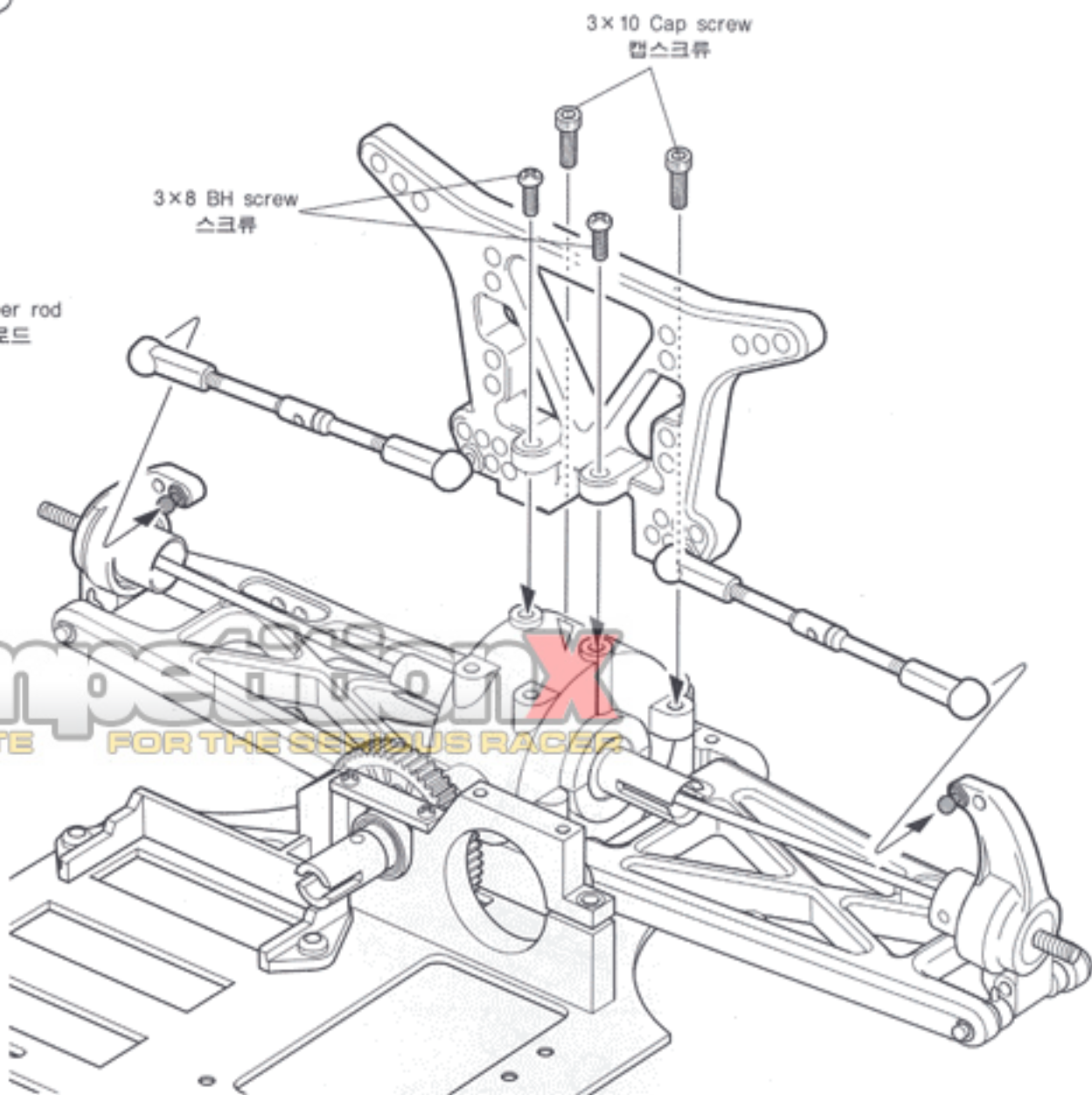

COMPETITION  
A WEB SITE FOR THE SERIOUS RACER

**13** G  

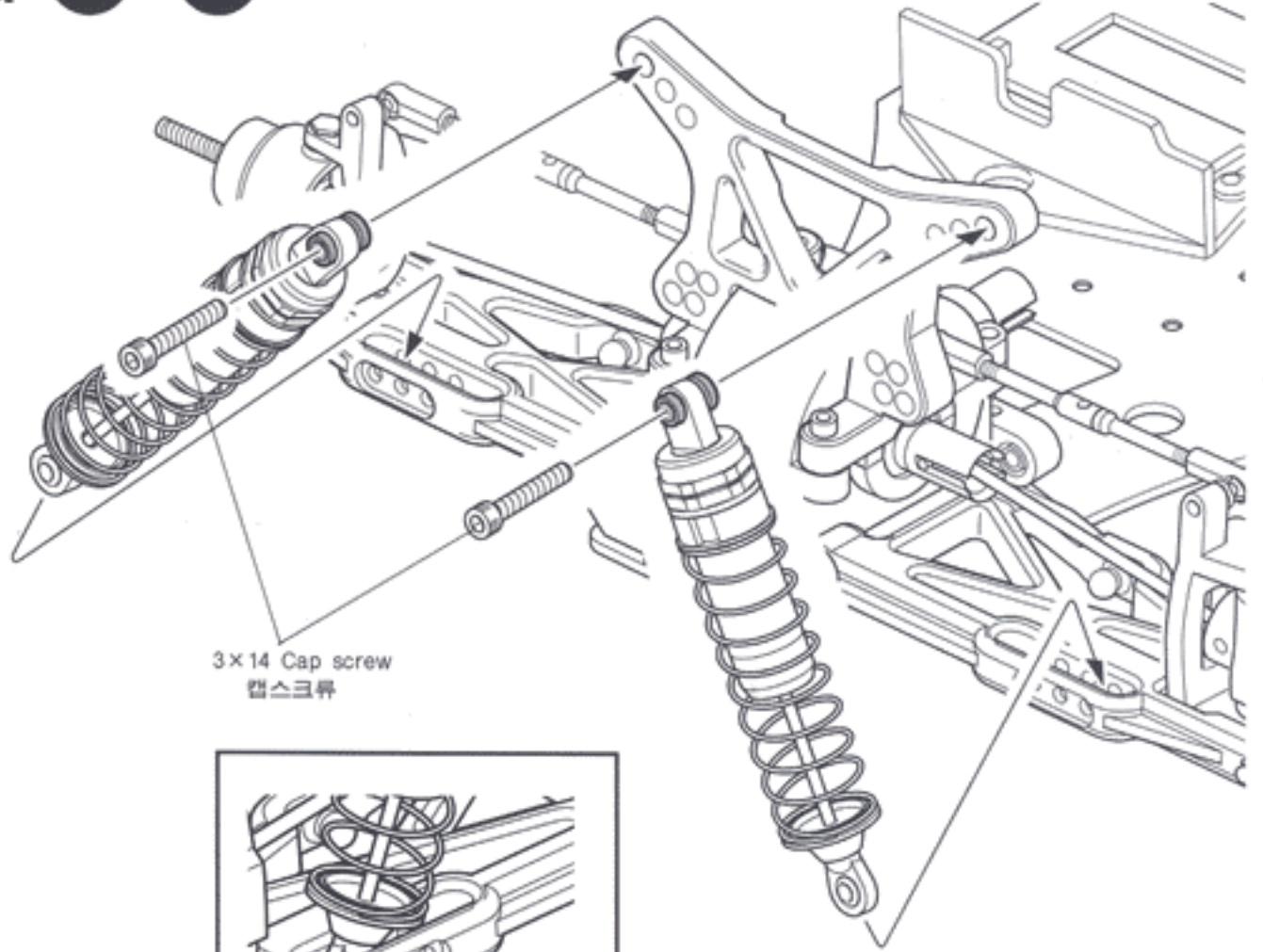

3 x 14 Cap screw 2  
캡스크류



3 x 12 Cap screw 2  
캡스크류

3 x 14 Cap screw  
캡스크류

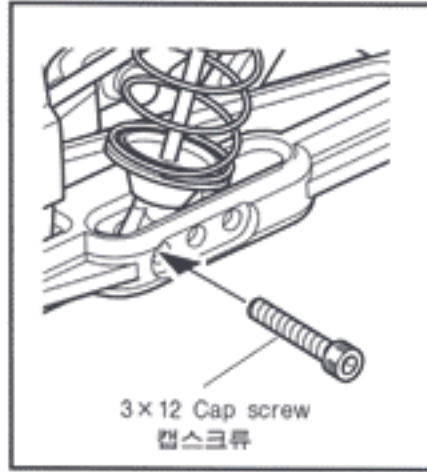

3 x 12 Cap screw  
캡스크류

**14** G 

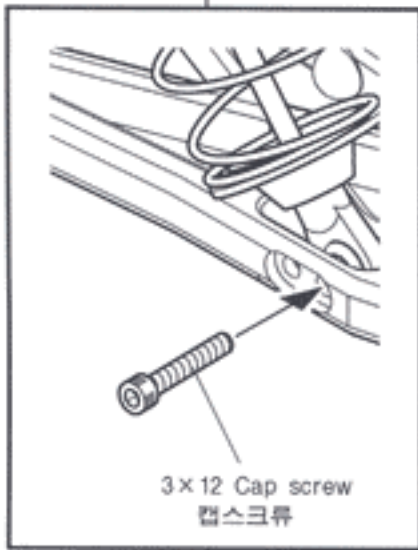

3 x 12 Cap screw  
캡스크류



3 x 14 Cap screw 2  
캡스크류



3 x 12 Cap screw 2  
캡스크류

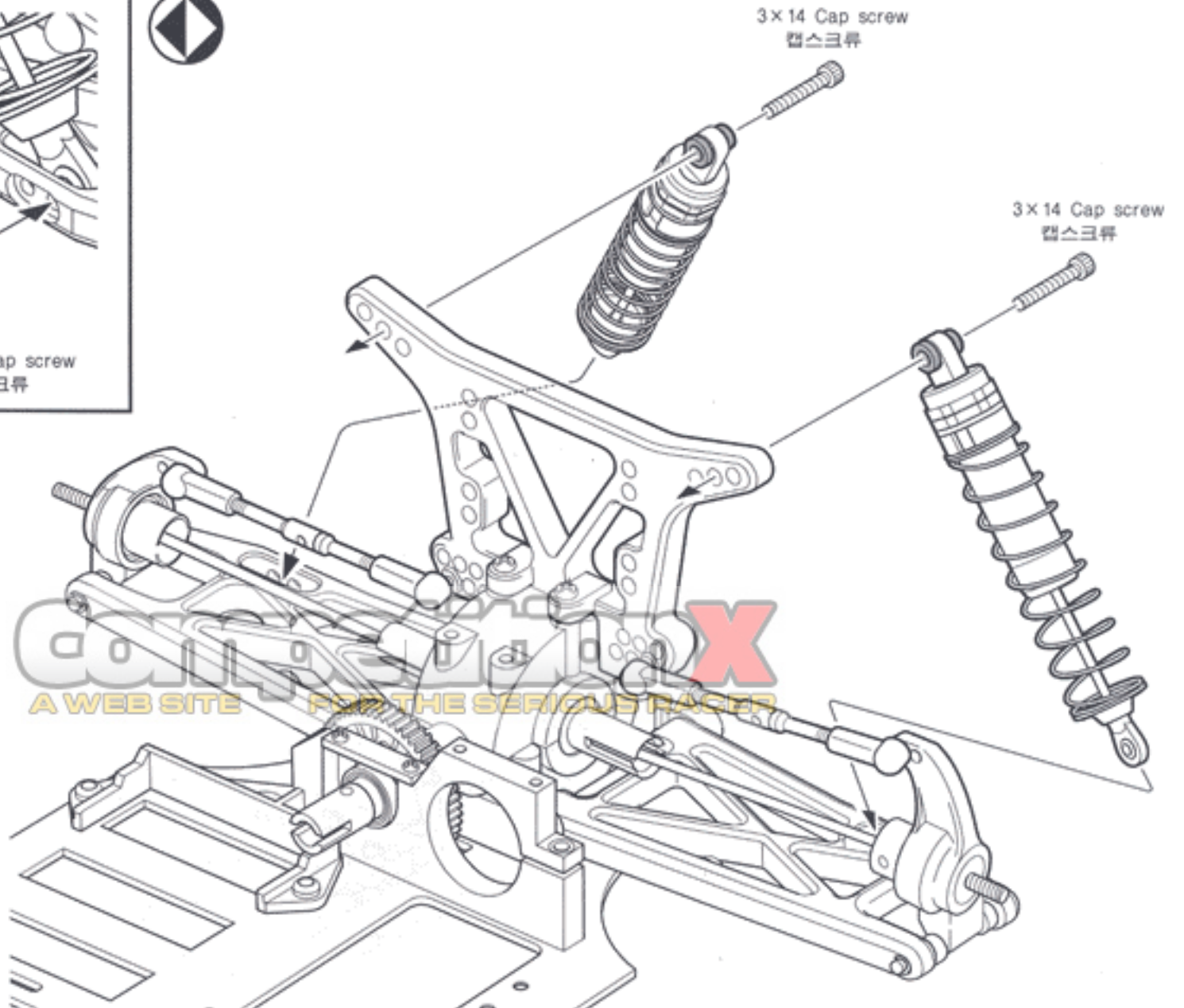

3 x 14 Cap screw  
캡스크류

3 x 14 Cap screw  
캡스크류

GOLFBIKE  
A WEB SITE FOR THE SERIOUS RACER

# 15 H

  $\phi$ 4.3 Pin ball 핀볼 5

 Saver spring adjuster 세이버스프링어저스터 1

 Saver spring 세이버스프링 1

 F840 Bush 부시 2

 Upper deck post B 어퍼데크포스트 2

 Upper deck post C 어퍼데크포스트 1

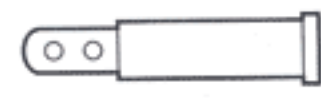
 Battery strap post 배터리스트랩포스트 1

 3x8 F/H Screw 접시볼트 4

  $\phi$ 5 E-Ring E-링 2

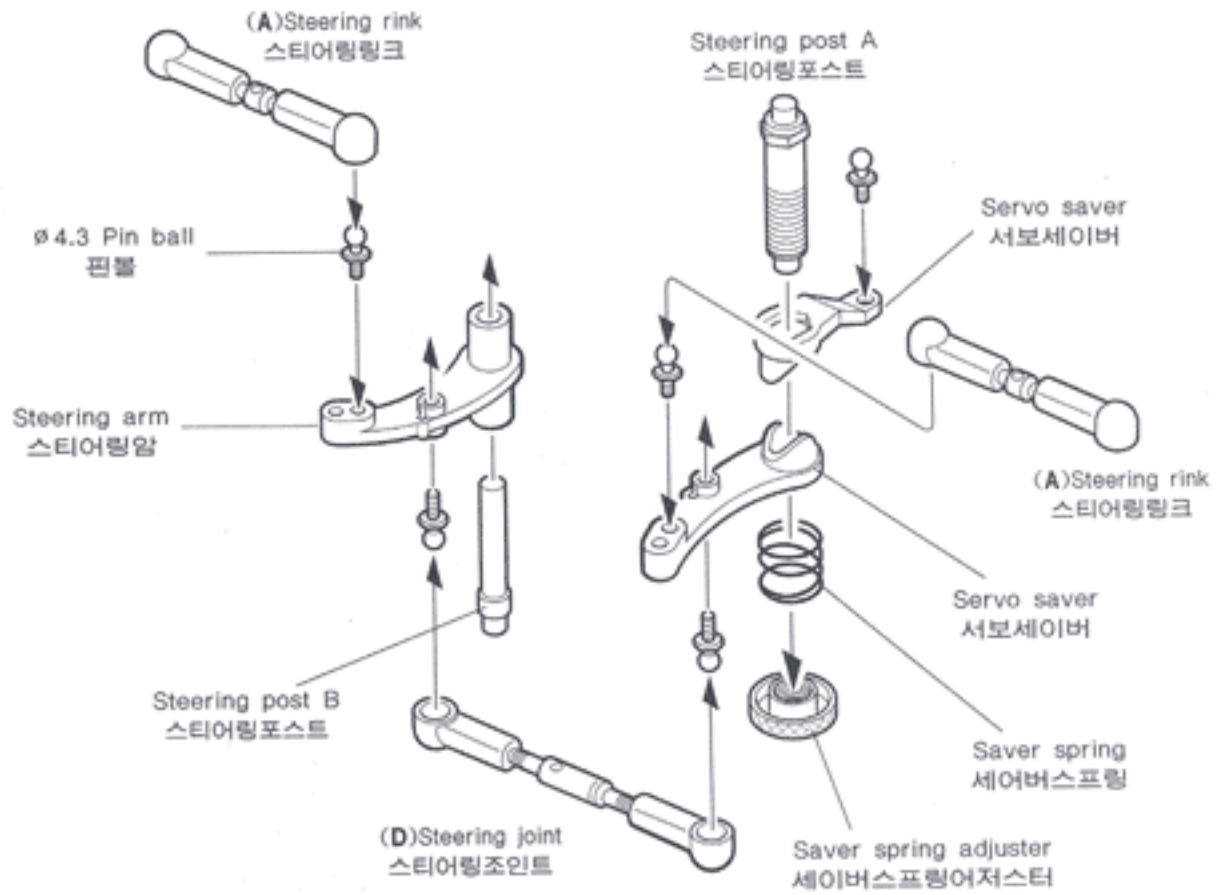

# 16 H

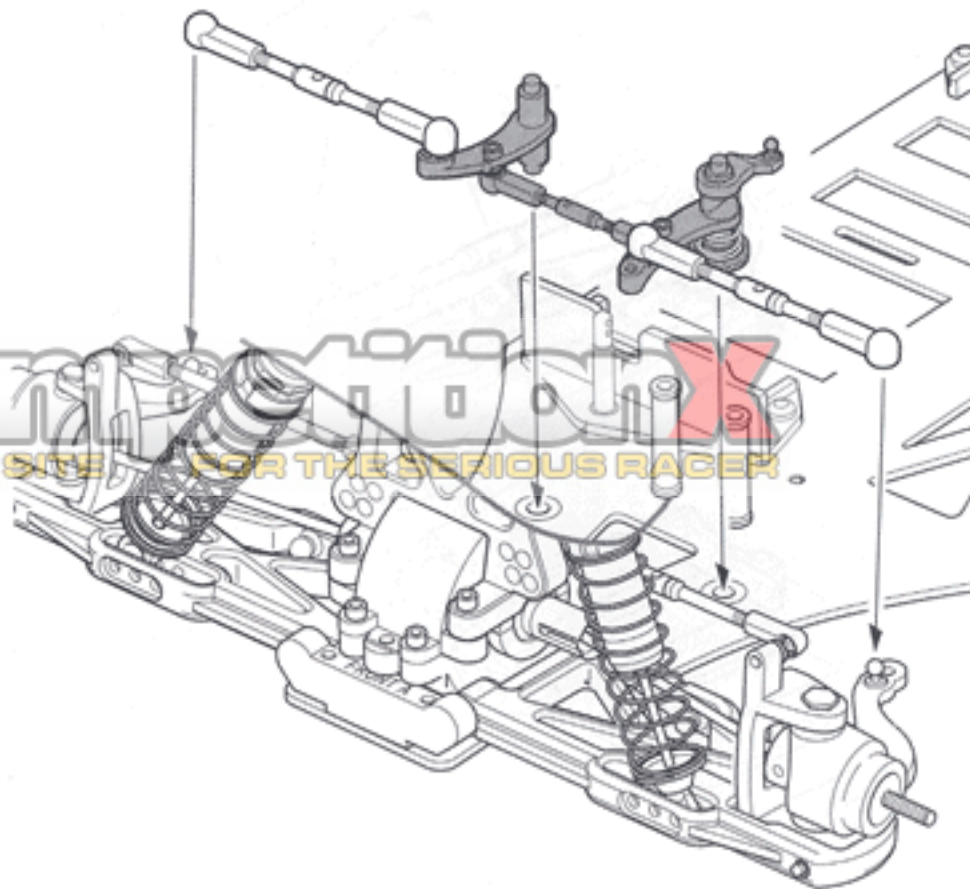
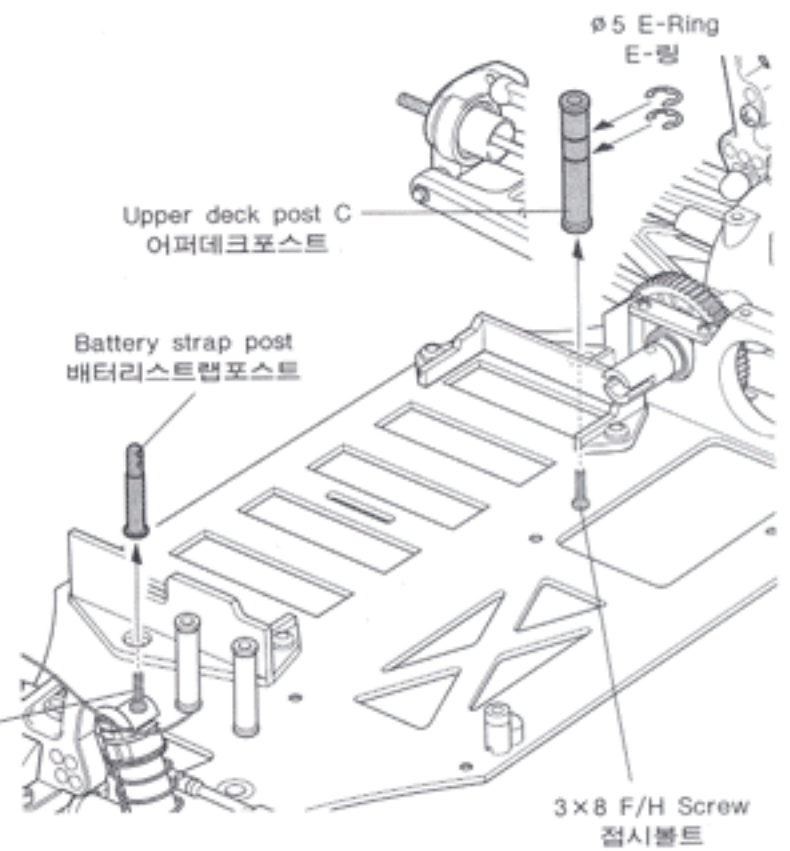
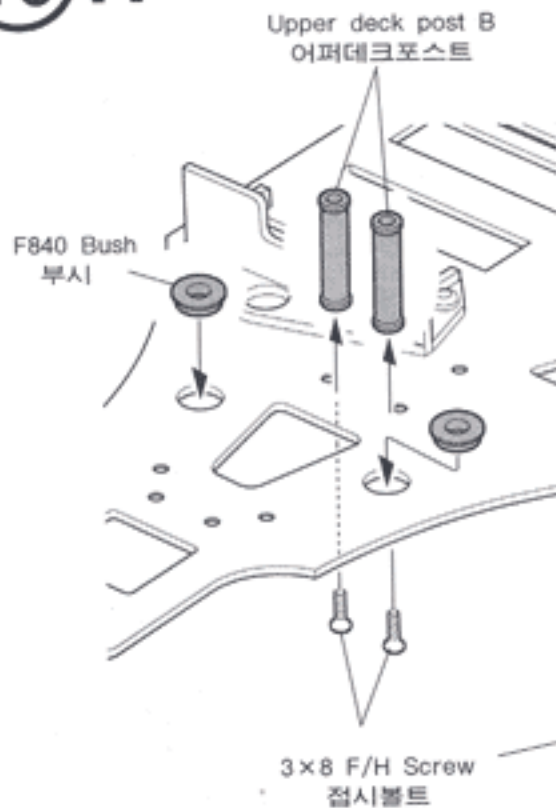

# 17 I



Front upper plate spacer 2  
프론트 아퍼플레이트 스페이서



F840 Bush 2  
부시



F/H Washer 2  
와셔



3x16 F/H Screw 2  
접시볼트



Joint cup spring 1  
조인트컵스프링

# 17 I

## Tuning part:

**ST-T23**  
Carbon Front Upper Plate  
카본프론트아퍼플레이트

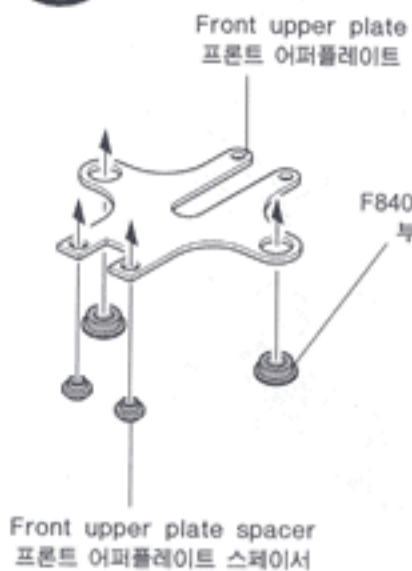

## Tuning part:

**ST-P06**  
Carbon Center Drive Shaft  
카본센터드라이브샤프트

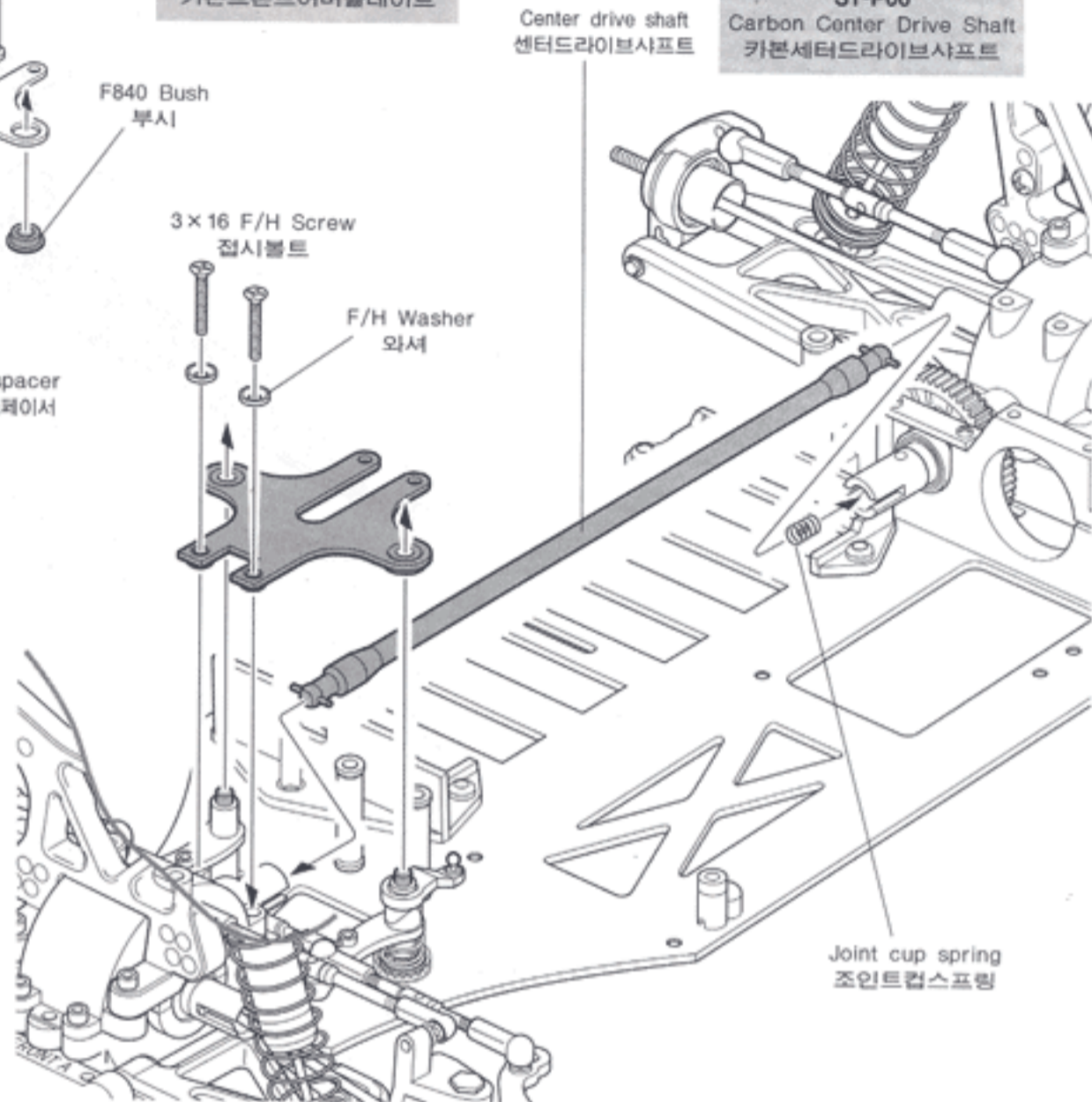

# 18 I



F/H Washer 7  
와셔



3x22 F/H Screw 2  
접시볼트



3x8 F/H Screw 5  
접시볼트



Upper deck post A 2  
어퍼데크포스트 A

## Tuning part:

**ST-P17**  
Carbon Upper Deck  
카본어퍼데크

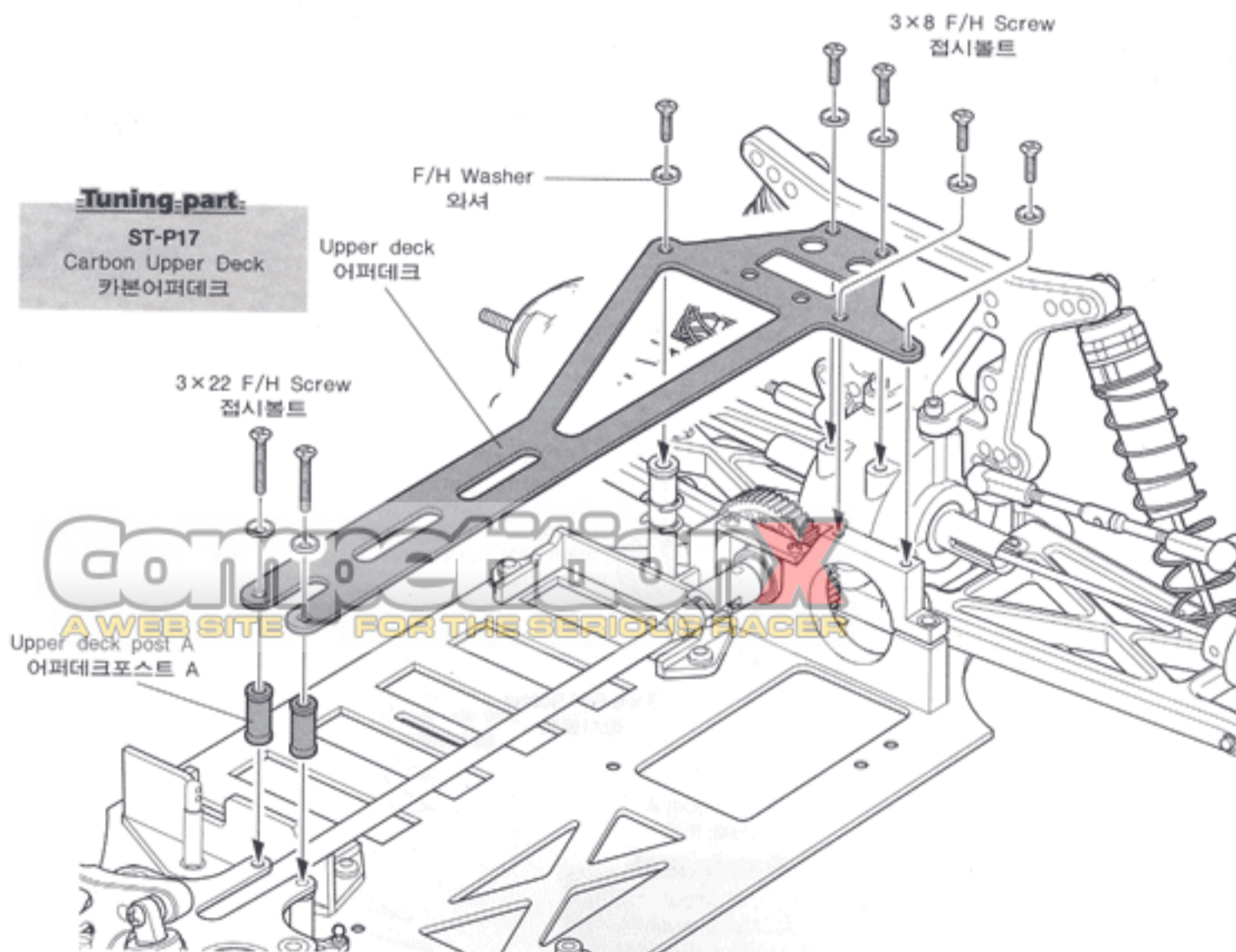

COMPETITION  
A WEB SITE FOR THE SERIOUS RACER

19 |

**Tuning part:**

**ST-P18**  
Carbon Battery Strap  
카본배터리스트랩

Battery Strap  
배터리스트랩



Straight pack  
스트레이트팩



Stick pack  
스틱팩

Body pin  
바디핀

Body pin 1  
바디핀

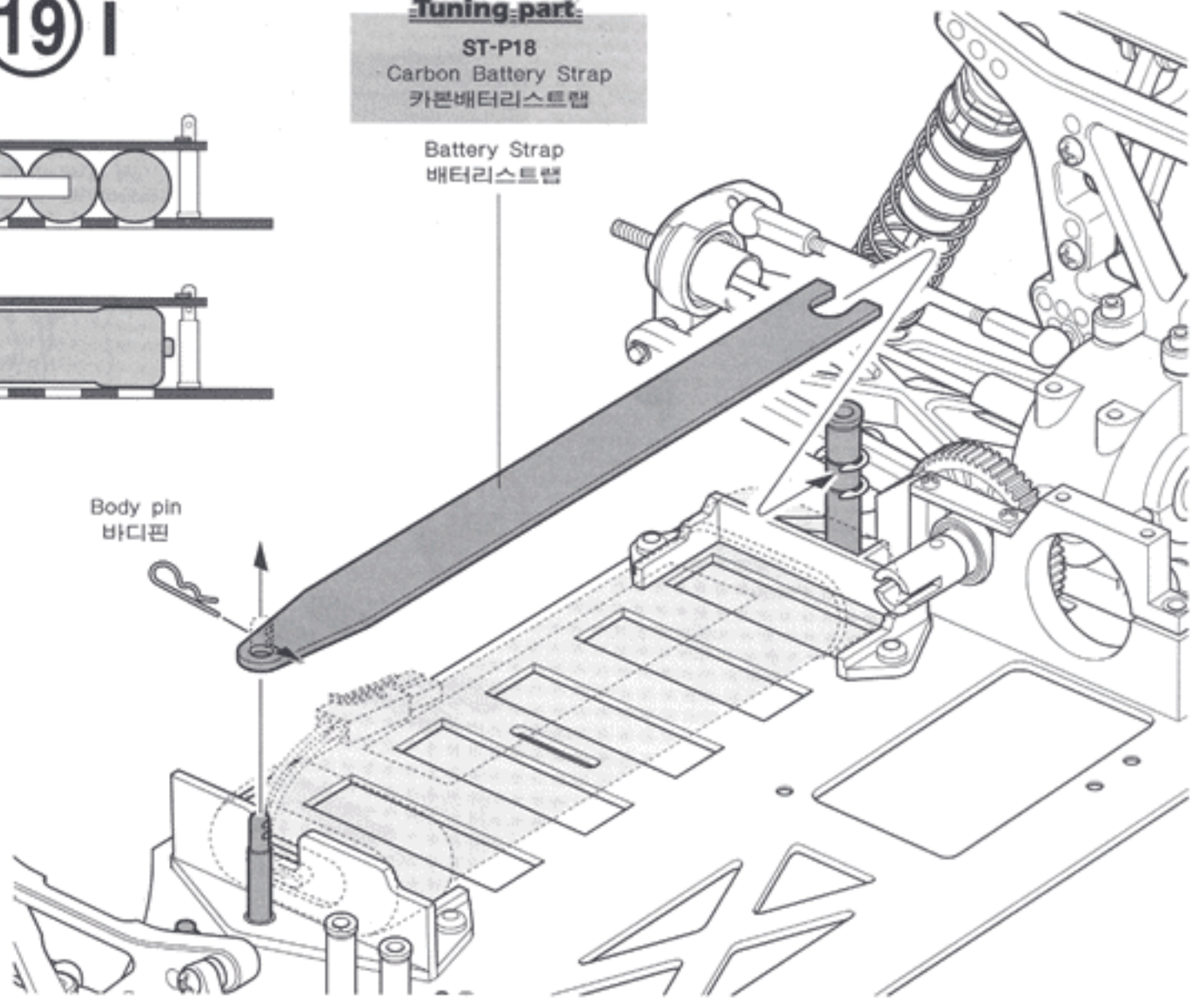

20 |

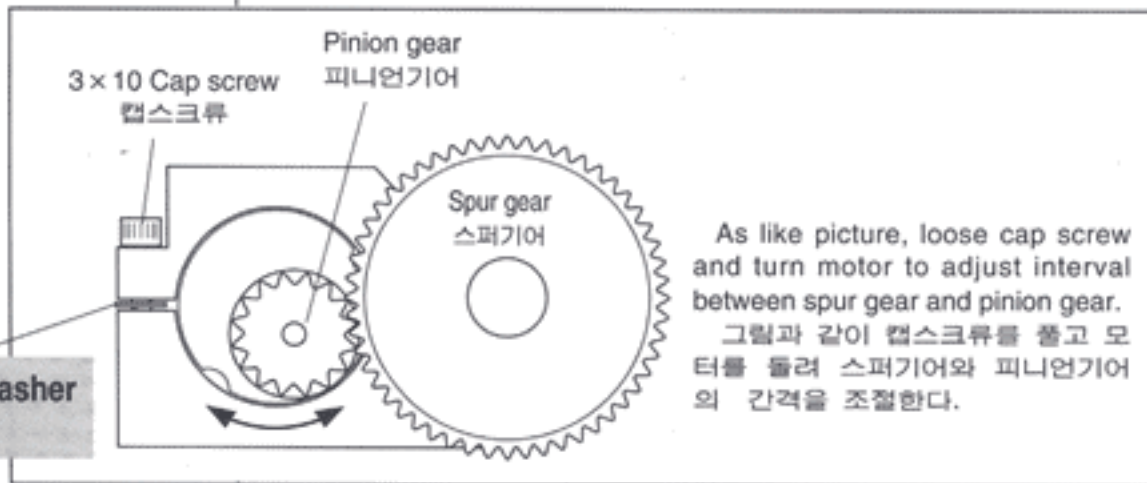

3 x 10 Cap screw  
캡스크류

Pinion gear  
피니언기어

Spur gear  
스퍼기어

3 x 6 x 0.5t Washer  
와셔

As like picture, loose cap screw and turn motor to adjust interval between spur gear and pinion gear.  
그림과 같이 캡스크류를 풀고 모터를 돌려 스퍼기어와 피니언기어의 간격을 조절한다.

3 x 10 Cap screw  
캡스크류

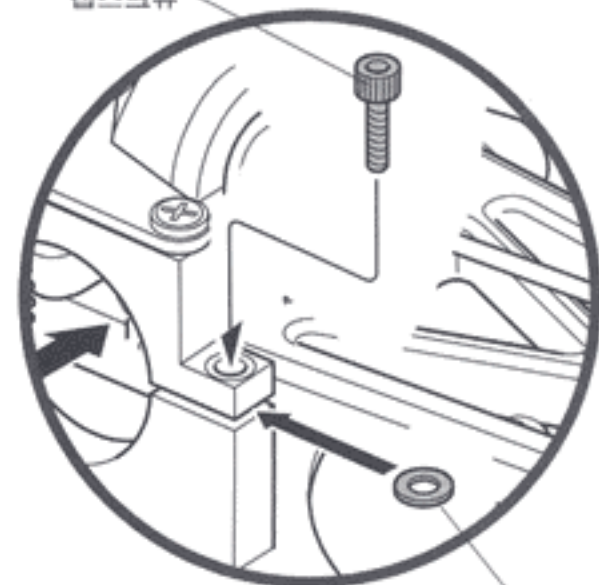

3 x 6 x 0.5t Washer  
와셔

3 x 10 Cap screw 1  
캡스크류

3 x 6 F/H Screw 2  
접시볼트

3 x 3 Set screw 1  
육각렌치볼트

3 x 3 Set screw  
육각렌치볼트

Pinion gear  
피니언기어

3 x 6 F/H Screw  
접시볼트

Motor mount A  
모터마운트

**Tuning part:**

**ST-T20**  
AL Motor Mount A  
알루미늄모터마운트A

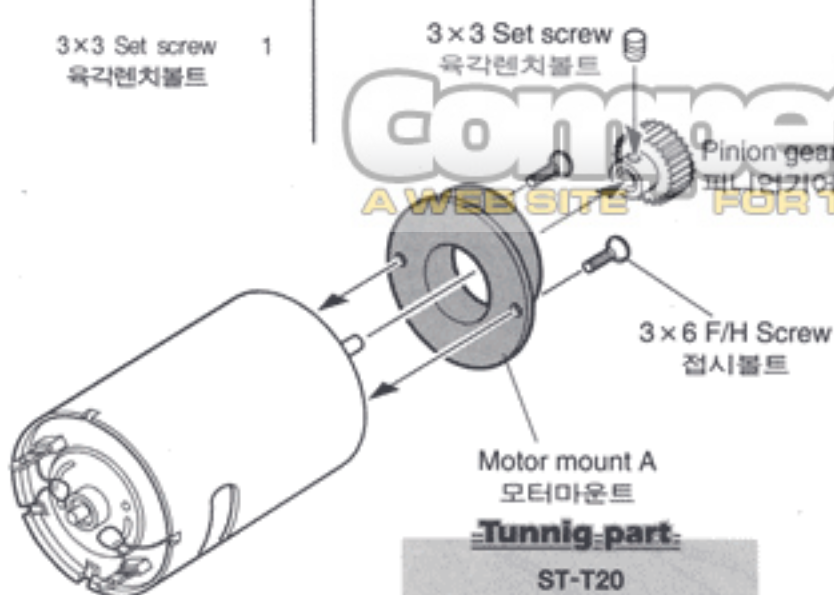

3 x 10 Cap screw  
캡스크류

3 x 6 x 0.5t Washer  
와셔

Motor Heat sink  
모터방열판

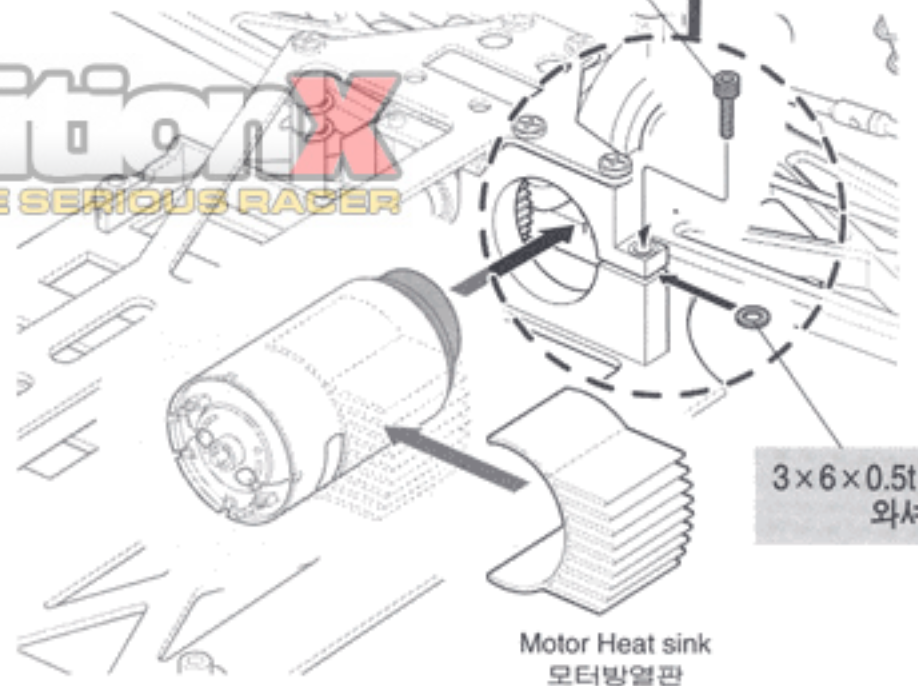

# 21 J

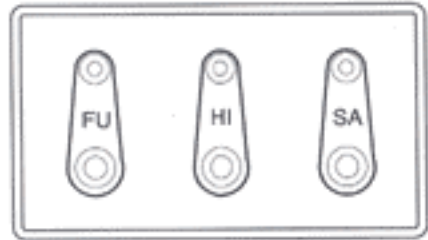

FUTABA 후디바    HITEC 하이텍    SANWA 산와

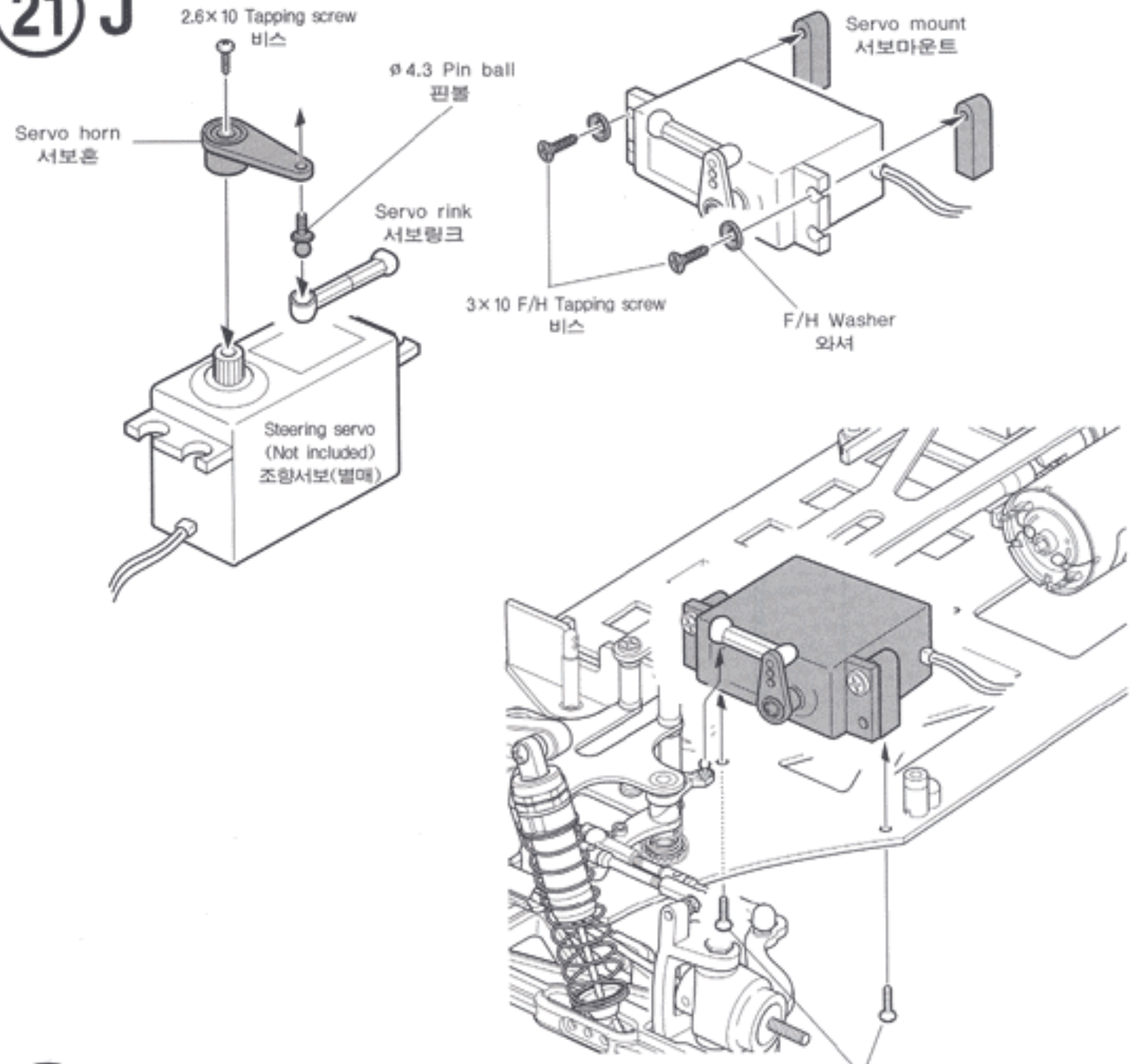

- 2.6x10 Tapping screw 비스 1
- F/H Washer 와셔 2
- 3x10 F/H Tapping screw 비스 4
- $\phi$  4.3 Pin ball 핀볼 1

# 22 J

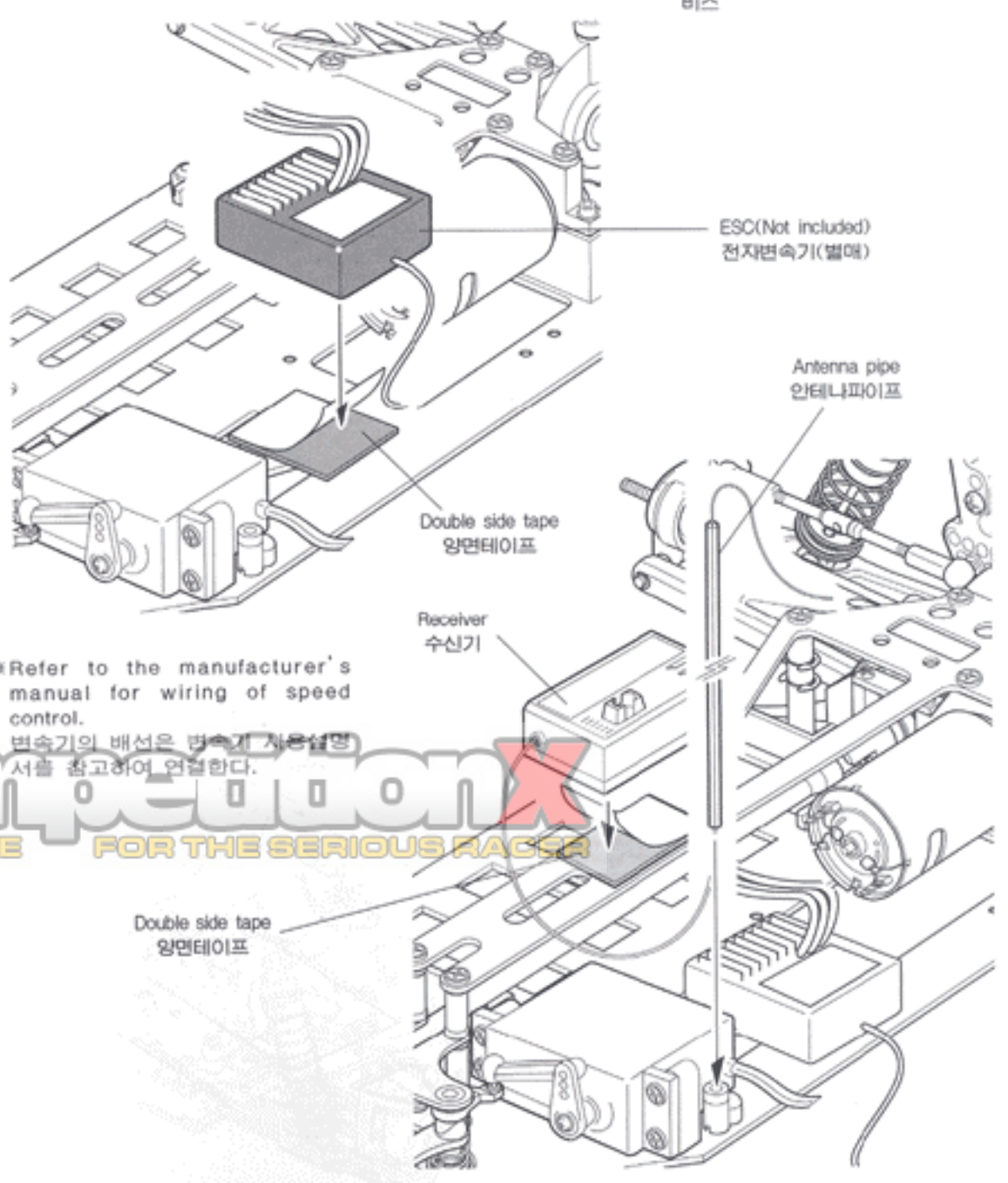
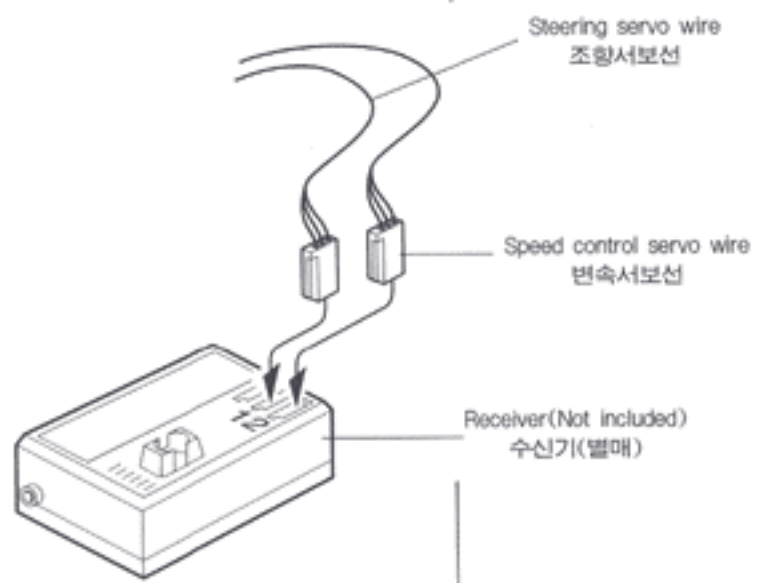

※Refer to the manufacturer's manual for wiring of speed control.  
 변속기의 배선은 변속기 사용설명서를 참고하여 연결한다.

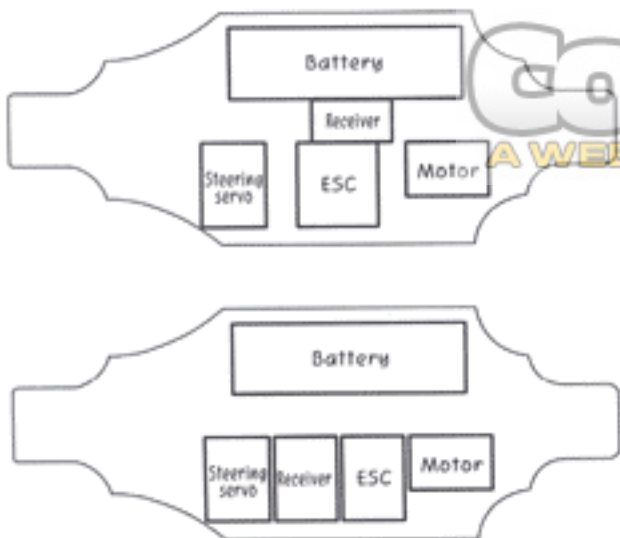

**Competition**  
 A WEB SITE FOR THE SERIOUS RACER

# 23 J

 3x10 Cap screw 4  
캡스크류

 3x8 Washer 4  
와셔

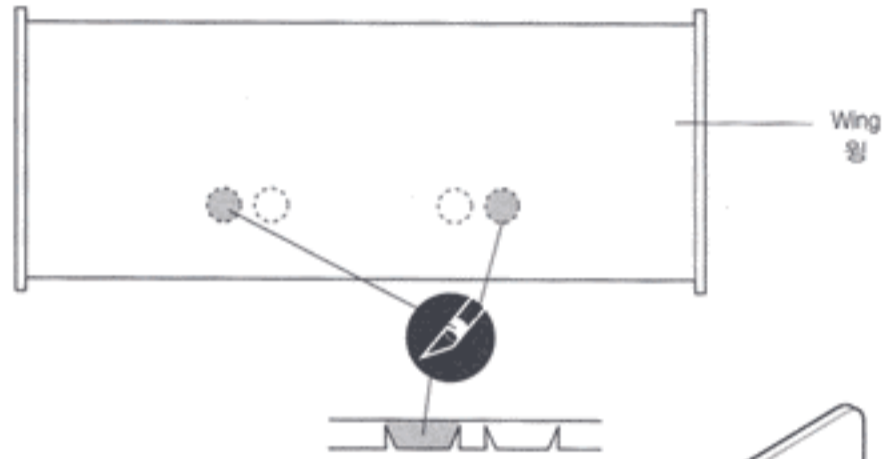
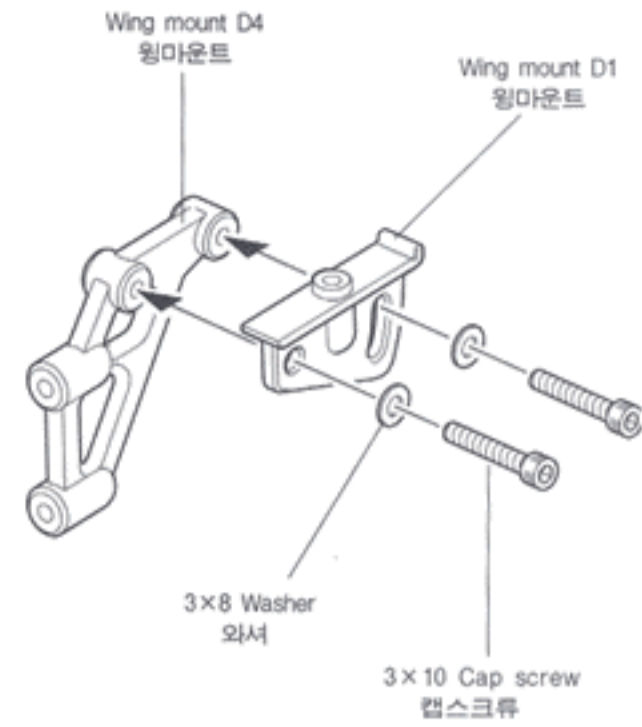
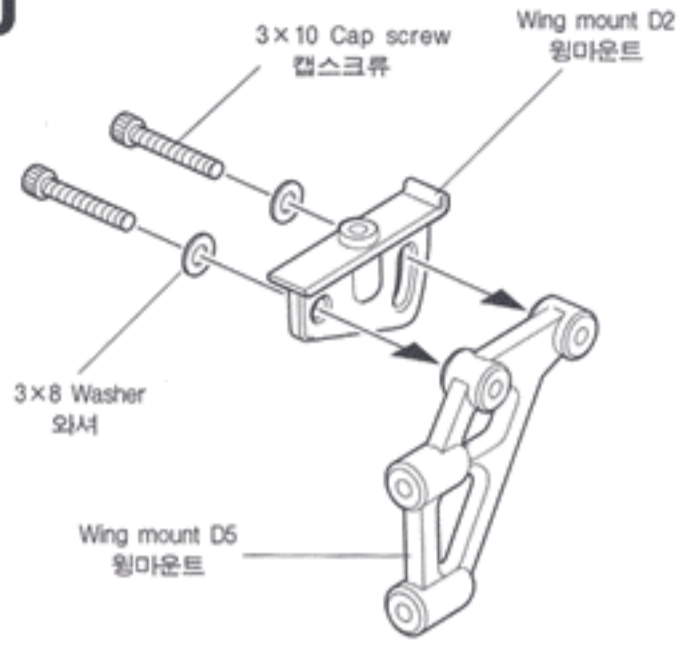

3x10 F/H Tapping screw  
비스

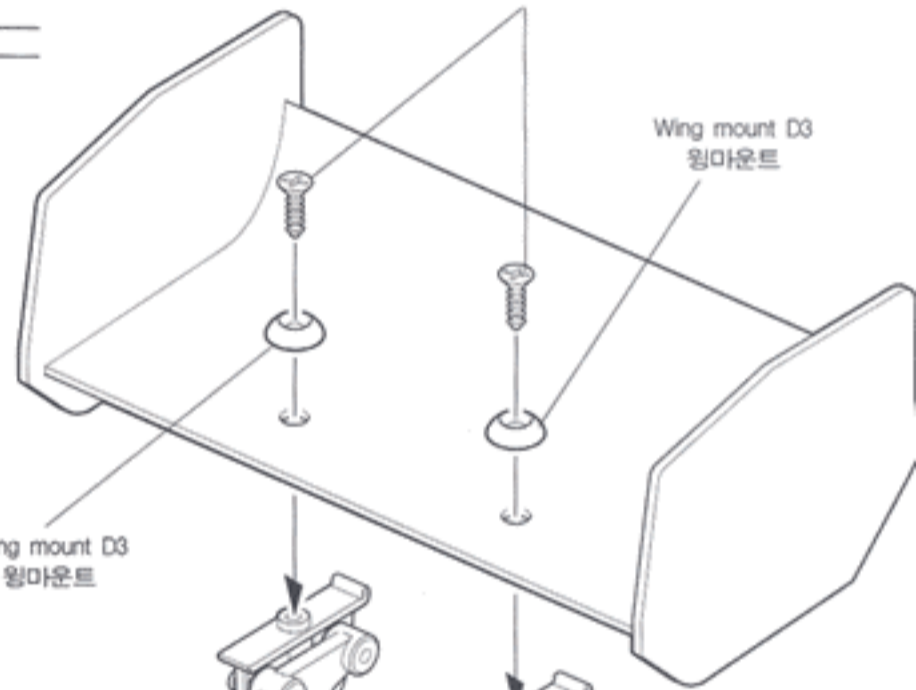

 3x10 F/H  
Tapping screw 2  
비스

 3x15 B/H Tapping screw 4  
비스

3x15 B/H Tapping screw  
비스

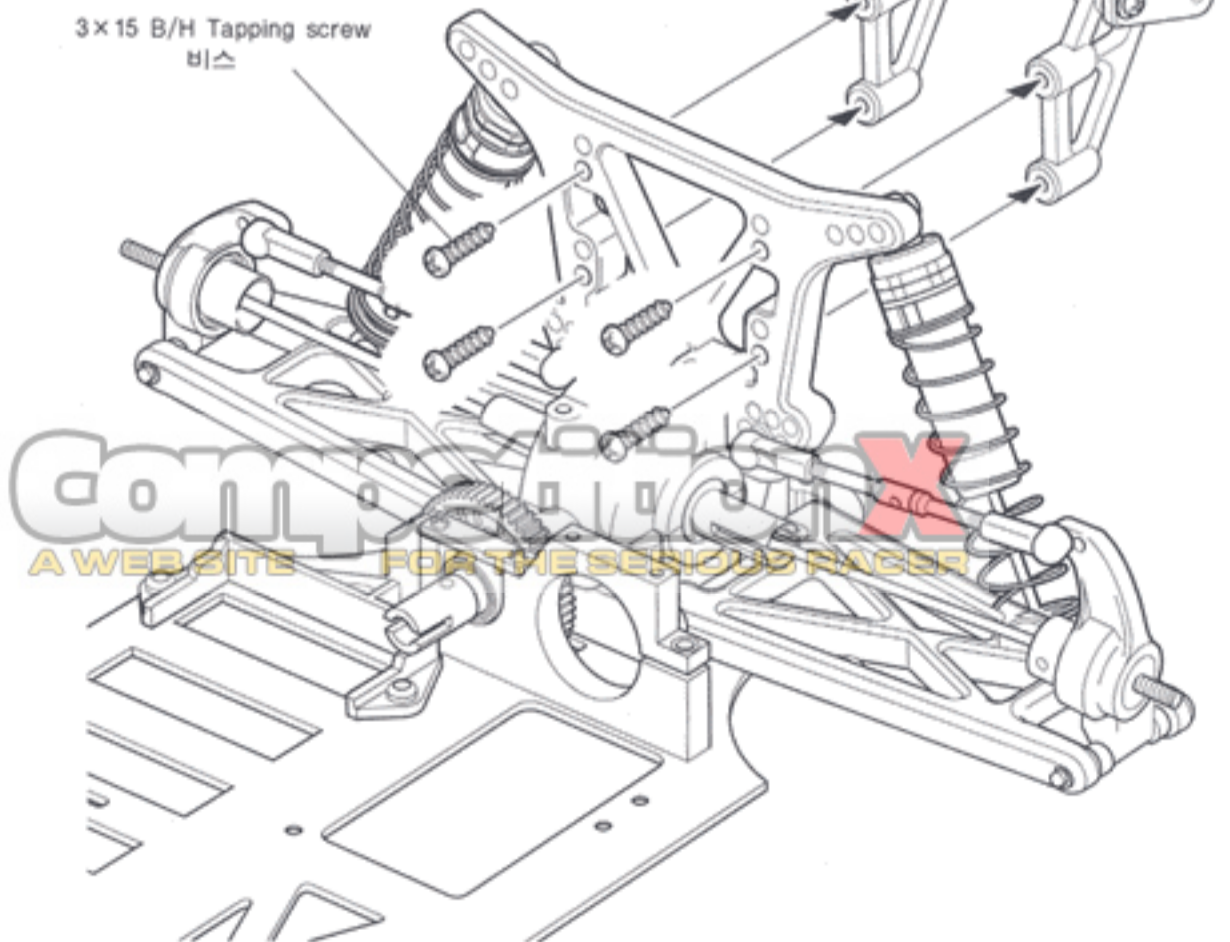

COMPTON  
A WEB SITE FOR THE SERIOUS RACER



24 J  

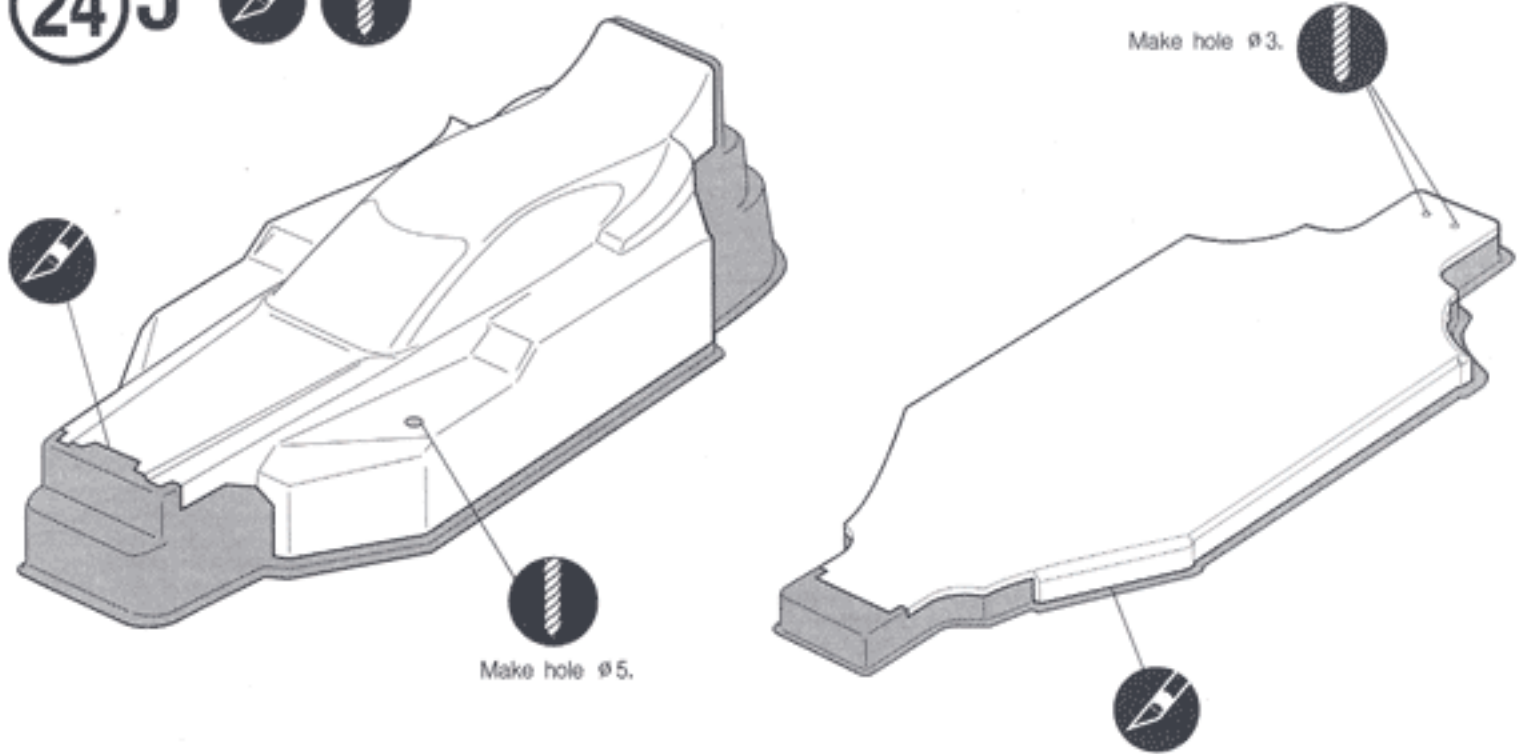

### ■ Painting 색칠하기

- 1) 색칠전에 중성세제로 내부를 씻어 준다.  
Before painting, wash inside with neutral detergent.
- 2) 창문에 마스킹을 한 후 폴리카보네이트 페인트를 칠해 준다.  
Apply polycarbonate painting after masking off windows.
- 3) 색칠이 마르면 마스킹과 보호 필름을 벗겨 낸다.  
When paintings are dried out, peel off masking and protective films.

### ■ NOTICE (참고)

Attach the decals as you want.

스티커는 상자그림을 참조하여 임의대로 붙인다.

 3x10 F/H Tapping screw 4 비스

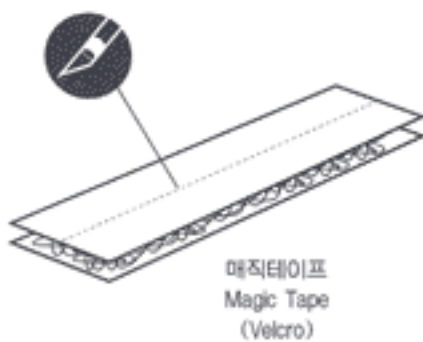
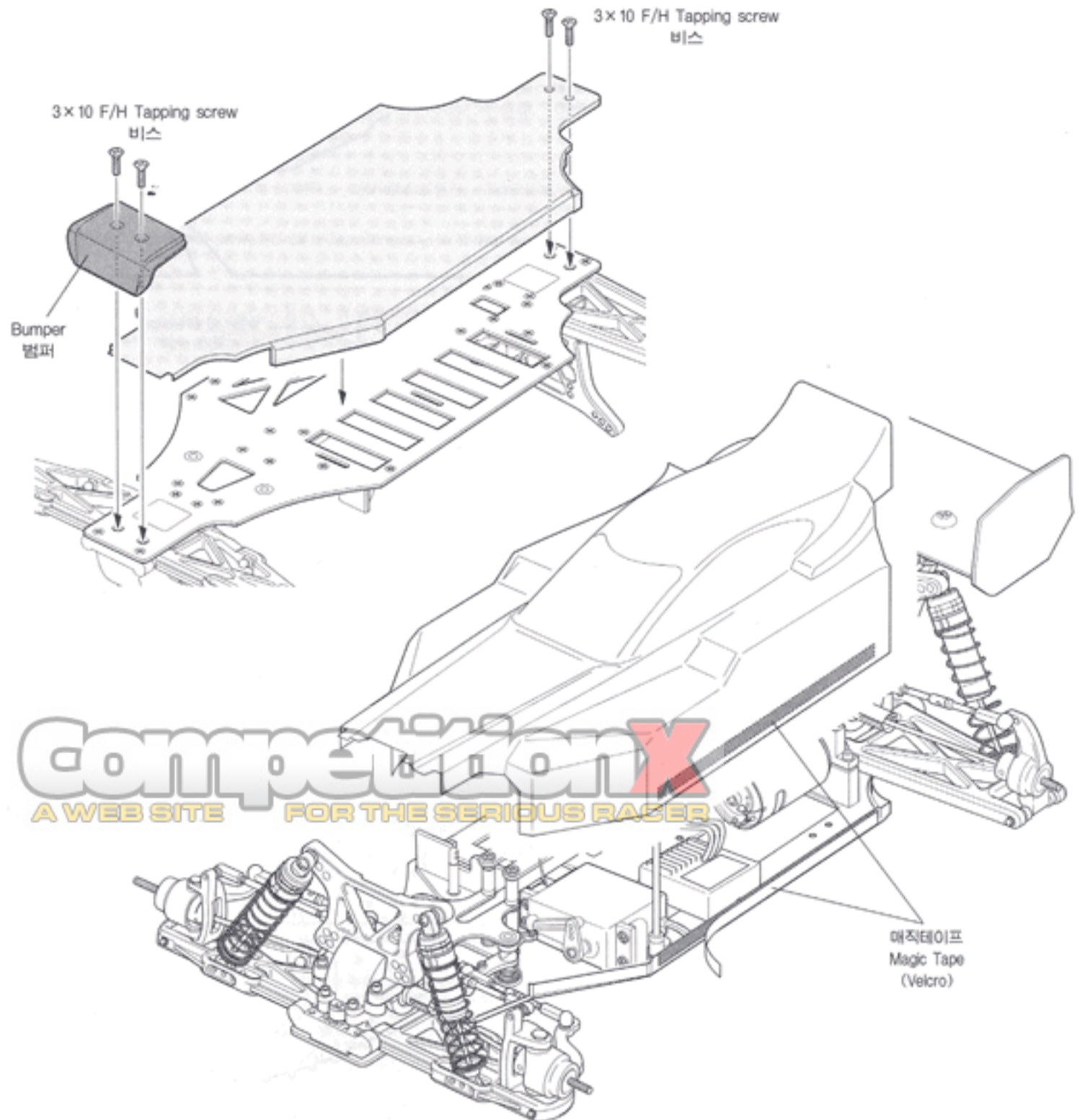

25



Front wheel  
프론트휠

Rear wheel  
리어휠

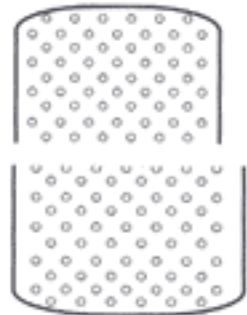

Front tire  
프론트타이어

Rear tire  
리어타이어



Front Hub  
프론트허브



ø4 Nylon nut 4  
나일론너트



Wheel hub 4  
휠허브

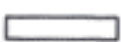

ø2x10 Drive pin 4  
드라이브핀



ø5x8x0.2t Washer 8  
와셔

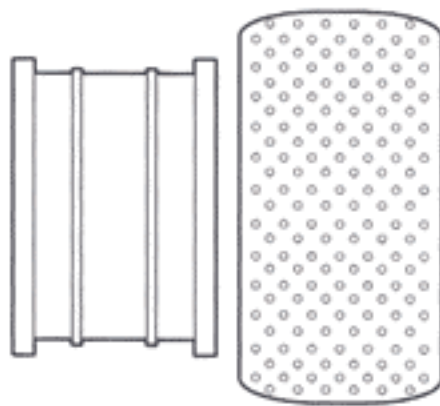

Front wheel  
프론트휠

Front tire  
프론트타이어

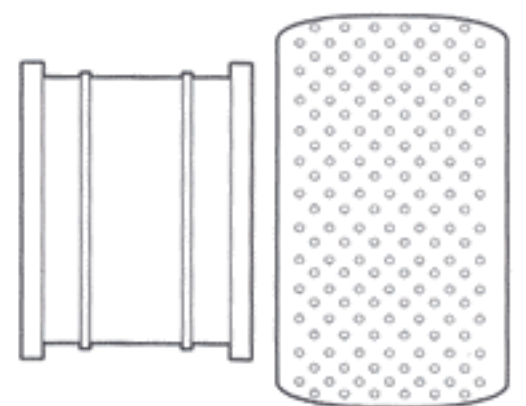

Rear wheel  
리어휠

Rear tire  
리어타이어

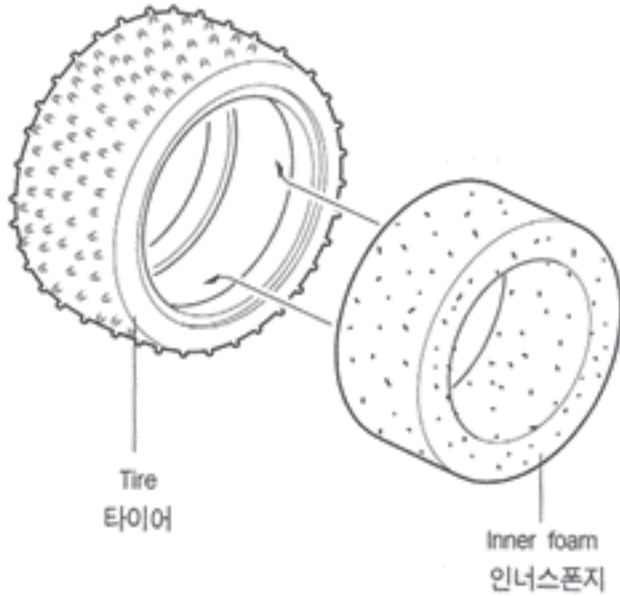

Tire  
타이어

Inner foam  
인너스폰지

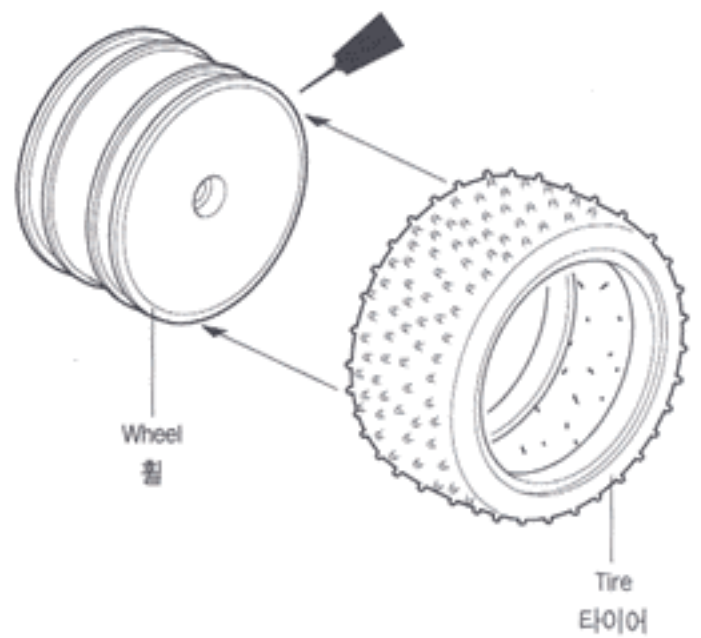

Wheel  
휠

Tire  
타이어

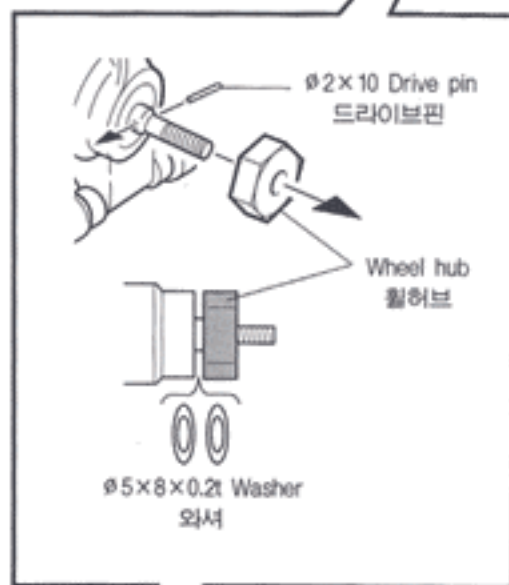
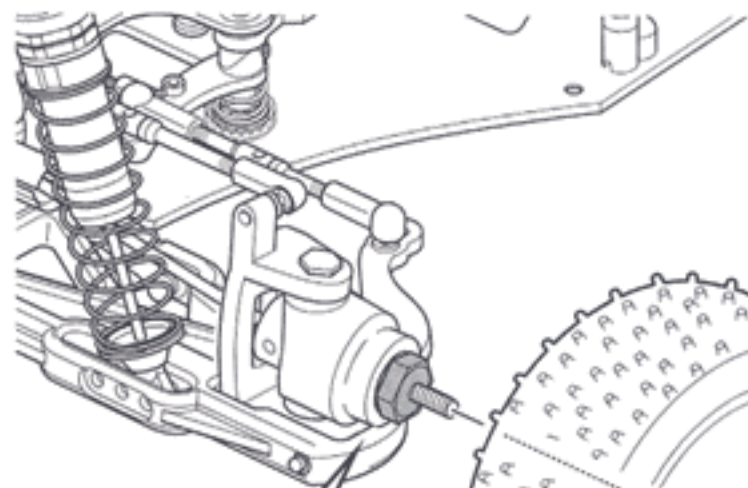

ø2x10 Drive pin  
드라이브핀

Wheel hub  
휠허브

ø5x8x0.2t Washer  
와셔

ø4 Nylon nut  
나일론너트

※휠허브와 베어링 사이의 유격을 와셔(ø5x8x0.2t Washer)를 이용하여 조절한다.  
Put Washer(ø5x8x0.2t) between Wheel Hub and Bearing to adjust engagement.

Operation X  
A WEB SITE FOR THE SERIOUS RACER

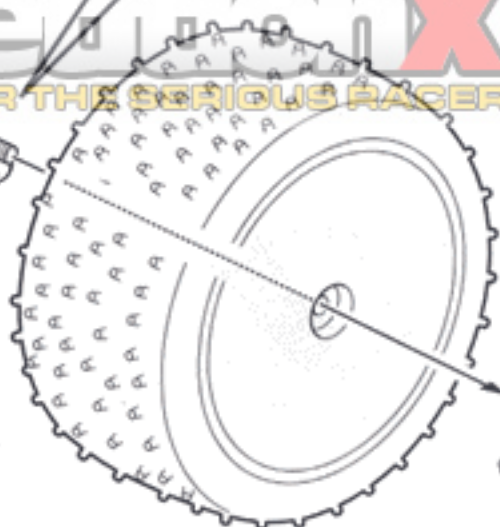

ø4 Nylon nut  
나일론너트

# SB Sport Packing List

PACKING	SB Sport BUGGY
SB-A	<p>새시X1, 전륜로어암X2, 후륜로어암X2, 로어암마운트세트X1, 3X8접시비스X5, 3X12접시볼트X8, #3x6와셔x8, 55mm힌지핀X4, 배터리가이드(전)X1, 배터리가이드(후)X1, 인테나포스트X1, #1.5L렌치X1, #2L렌치X1, #2.5L렌치X1, 십자렌치X1</p> <p>ChassisX1, Front Lower ArmX2, Rear Lower ArmX2, Lower Arm Mount SetX1, #3X8 F/H Tapping ScrewX5, #3X12 F/H ScrewX8, #3X6 WasherX8, 55mm Hinge PinX4, Battery Guard(F)X1, Battery Guard(R)X1, Antenna PostX1, #1.5Allen KeyX1, #2.0Allen KeyX1, #2.5Allen keyX1, WrenchX1</p>
SB-B	<p>44T베벨기어X2, 사출부쉬X2, 사출너트(소)x2, 디스크와셔x4, 850오일레스메탈X4, #2.5디프볼X24, #2트러스트볼X12, 볼디프너트X2, 2x25볼디프스크류X2, 2x6트러스트와셔X4, 디프스프링X2, 볼디프너트X2, 볼디프너트X2, 실리콘그리스(대)x1</p> <p>44T Bevel GearX2, BushX2, Plastic CapX2, Disk WasherX4, 850 Oilless MetalX4, #2.5Diff BallX24, #2Thrust BallX12, Ball Diff NutX2, 2x25Ball Diff ScrewX2, 2X6Thrust WasherX4, Ball Diff SpringX2, Ball Diff HubX2, Silicon GreaseX1</p>
SB-C	<p>기어박스(하)전.후X1, 기어박스(상)전.후X1, 1510베벨어링X5, 1050베벨어링X4, 1.5X7.5핀X2, 2X10핀X1, #4C스톱링X2, 16T 베벨기어X2, 4X4세트스크류X2, 10x13x0.2t와셔x6, 센터조인트컵X2, 센터드라이브샤프트스페이서X1, 3X8 접시볼트X3, 2X6 볼트X2, 전륜베벨기어샤프트X1, 후륜베벨기어샤프트X1, 3X10접시비스X4, 3X6볼트X4, 3X10캡스크류X8, AL스퍼기어어댑터X1, 스퍼기어(62T,65T,67T,70T각)X1, 진동방지모터마운트X1, 베어링홀더X1, 사출캡x1, 3x6x0.5t와셔x1</p> <p>Gear Box(Upper)F.RX1, Gear Box(Lower)F.RX1, 1510Ball BearingX5, 1050Ball BearingX4, 1.5X7.5PinX2, #4C-Stop RingX2, 2X10 Pin, 16T Bevel GearX2, 4X4Set ScrewX2, 10x13x0.2tWasherX6, Center Joint CupX2, Center Drive Shaft SpacerX1, 3X8 F/H ScrewX3, 2X6 P/H ScrewX2, Front Bevel Gear ShaftX1, Rear Bevel Gear ShaftX1, 3X10 F/H Tapping ScrewX4, 3X6 P/H ScrewX4, 3X10 Cap ScrewX6, AL Spur Gear AdapterX1, Spur Gear(62T,65T,67T,70T 1EA), Antivibration Motor MountX1, Bearing HolderX1, Plastic CapX1, 3x6x0.5t Washer x1</p>
SB-D	<p>전륜허브X2, 후륜허브X2, 허브캐리어(7°)L,RX1, 1510오일레스메탈X4, 1050오일레스메탈X4, 역축샤프트x2, 드라이브샤프트X2, 유니버셜샤프트X2, 유니버셜역축샤프트X2, 4.5x7.5 조인트핀x2, 2x11 조인트핀x2, 3x2.5육각렌치볼트x2, #4.3핀볼X6, 링핀X4, 26.5mm힌지핀X2, 33mm힌지핀X2, #2 E-링X9, 역축샤프트 스프링x2</p> <p>Front HubX2, Rear HubX2, Hub Carrier(7°)L - RX1, 1510 Oilless MetalX4, 1050 Oilless MetalX4, Axle Shaft x2, Drive Shaftx2, Universal ShaftX2, Universal Axle Shaft x2, 4.5x7.5Joint Pin x2, 2x11Joint Pin x2, 3x2.5 Set Screw x2, #4.3Pin BallX6, King PinX4, 26.5mm Hinge PinX2, 33mm Hinge PinX2, #2E-RingX9, Axle Shaft Springx2</p>
SB-E	<p>#4.3볼엔드X20, 50mm로드x4, 34mm로드x1, 44mm로드x2</p> <p>#4.3 Super Ball EndX20, 50mm Rodx4, 34mm Rodx1, 44mm Rodx2</p>
SB-F	<p>댐퍼파트X2Set, 60mm댐퍼스프링x2, 42mm댐퍼스프링x2, 9mm댐퍼캡x4, 7mm댐퍼캡x4, 스프링가드x4, 1mm댐퍼텐셔너x4, 2mm댐퍼텐셔너x4, 3mm댐퍼텐셔너x4, 4mm댐퍼텐셔너x4, 5mm댐퍼텐셔너x4, 알루미늄댐퍼캡x4, #3O-링x8, 디어프렘x4, 댐퍼클립스프링x4, 댐퍼실린더(M)x2, 댐퍼실린더(S)x2, 40mm댐퍼샤프트x2, 50mm댐퍼샤프트x2, #2 E-링x9, #5.8볼x4, 실리콘오일x2, 댐퍼피스톤x4, 더스트캡x4</p> <p>Damper PartX2, 60mm Damper SpringX2, 42mm Damper SpringX2, 9mm Damper CapX4, 7mm Damper CapX4, Spring GuardX4, 1mm Damper TensionerX4, 2mm Damper TensionerX4, 3mm Damper TensionerX4, 4mm Damper TensionerX4, 5mm Damper TensionerX4, AL Damper CapX4, #3 O-RingX8, DiaphragmX4, Damper Clip SpringX4, Damper Cylinder(M)X2, Damper Cylinder(S)X2, 40mm Damper ShaftX2, 50mm Damper ShaftX2, #2 E-Ring x9, #5.8 Ball x4, Silicon Oil x2, Damper PistonX4, Dust CapX4</p>
SB-G	<p>전륜댐퍼스테이X1, 후륜댐퍼스테이X1, 3X14캡스크류X4, 3X12캡스크류X4, 3X10캡스크류X4, 3X8 B/H볼트X4, #4.3핀볼x4</p> <p>Front Damper StayX1, Rear Damper StayX1, 3X14Cap ScrewX4, 3X12Cap ScrewX4, 3X10 Cap ScrewX4, 3X8 B/H ScrewX8, #4.3 Pin BallX4</p>
SB-H	<p>서보세이버X1Set, 어저스터블스티어링포스트X1, 4X29스티어링포스트X1, 세이버스프링어저스터X1, 세이버스프링X1, 배터리스트랩포스트X1, 어퍼데크포스트BX2, 어퍼데크포스트CX1, #4.3핀볼X5, 3X8접시볼트X4, #5E-링X2, F840오일레스메탈X2</p> <p>Servo Saver x1Set, Steering Post A - BX1, Saver Spring AdjusterX1, Saver SpringX1, Battery Strap PostX1, Upper Deck Post BX2, Upper Deck Post CX1, #4.3Pin BallX5, 3X8 F/H ScrewX4, #5 E-RingX2, F840 Oilless Metal x2</p>
SB-I	<p>AL센터드라이브샤프트x1, 배터리스트랩x1, 어퍼데크x1, 프론트어플레이트x1, 방열판x1, AL모터마운트어댑터x1, 어퍼데크포스트x2, 어퍼데크클레이스트스페이서x2, AL접시와셔x9, 3x8접시볼트x5, 3x16접시볼트x2, 3x22접시볼트x2, F840오일레스메탈x2, 바디핀x1, 3x6접시볼트x2, 3x3육각렌치볼트x1, 3x10캡스크류x1, 20T 피니온기어X1, 조인트캡스프링x1</p> <p>AL Center Drive Shaftx1, Battery Strapx1, Upper DeckX1, Front Upper PlateX1, Motor Heat SinkX1, Motor Mount AdapterX1, Upper Deck PostX2, Upper Plate SpacerX2, AL F/H WasherX9, 3X8 F/H ScrewX5, 3X16 F/H ScrewX2, 3X22 F/H ScrewX2, F840 Oilless Metalx2, Body PinX1, 3X6 F/H ScrewX2, 3X3Set ScrewX1, 3X10Cap ScrewX1, 20T Pinion GearX1, Joint Cup SpringX1</p>
SB-J	<p>30cm매직테이프x1, 윙x1, 전륜범퍼x1, 윙마운트세트x1, 25x75양면테이프x1, 서어보온x1세트, 2.6x10 비스x1, 3x15비스x4, 3x10접시비스x10, 3x10캡스크류x4, #3와셔x4, 5x8x0.2t트러스트와셔x8, 전시와셔x2, #4.3핀볼x1, 조항서어보마운트x2, #4나일론너트x4, 2x10드라이브핀x4, 알루미늄휠허브x4, 인너폼(전)x2, 인너폼(후)x2, 퓨전타이어(전)x2, 퓨전타이어(후)x2, 스티커x1, 디스크휠(전)x2, 디스크휠(후)x2, 배터리(상,하)x1</p> <p>30cm Magic TapeX1, WingX1, Front BumperX1, Wing Mount SetX1, 25X75 Double Side TapeX1, Servo Horn SetX1, 2.6X10 B/H Tap ScrewX1, 3X15 B/H Tap ScrewX4, 3X10 F/H Tap ScrewX10, 3X10 Cap ScrewX4, #3 WasherX4, 5X8X0.2t WasherX8, F/H WasherX2, #4.3 Pin BallX1, Servo MountX2, #4 Nylon NutX4, 2X10 Drive PinX4, AL Wheel HubX4, Inner Foam(F)X2, Inner Foam(R)X2, Fusion Tire(F)X2, Fusion Tire(R)X2, SlickerX1, Disk Wheel(F)X2, Disk Wheel(R)X2, Upper BodyX1, Under BodyX1</p>

**■부품이 파손되었거나 분실했을 경우**

●부품의 가격 및 판매에 관한 자세한 사항을 본사 서비스센터, 직매점, 총판점 및 가까운 과학교재사에 문의하시고 부품명과 부품번호를 확인하여 구입하시기 바랍니다.  
 ●직매점 겸 A/S센터      상선교: 742-9290, 발매동: 552-9293, 양재동: 575-9997, 용산: 796-1214, 아셈하버센터: 6002-6293, 구로하버센터: 853-9293  
 ●A/S센터                      본사: 906-7000(교동147), 동대문: 745-9293, 경호동: 473-9293  
 ●총판점 겸 A/S센터        동이카데미: 907-0940, 양천이카데미: 691-7108, 강남이카데미: 485-8884, 강북이카데미: 762-0980  
 A/S센터: (031)458-5591, 서면이카데미: (051)816-9773, 대구이카데미: (053)744-9293  
 이카데미피렌다: 586-9293  
 ●유통사접부                      http://www.academy.co.kr  
 ●홈페이지                      080-969-7000  
 ●고객상담문의

**ACADEMY**  
HOBBY MODEL KITS

**ACADEMY PLASTIC MODEL CO., LTD.**  
 273-64, Suyu-dong, Kangbuk-gu, Seoul, Korea  
 TEL:82-2-908-7000 FAX:82-2-997-3003

Name : \_\_\_\_\_  
 Date : \_\_\_\_\_  
 Track : \_\_\_\_\_

**Track conditions**

Size :  Open  Med.  Tight  
 Traction :  High  Med.  Low  
 Surface :  Smooth  Bumpy

## Front suspension

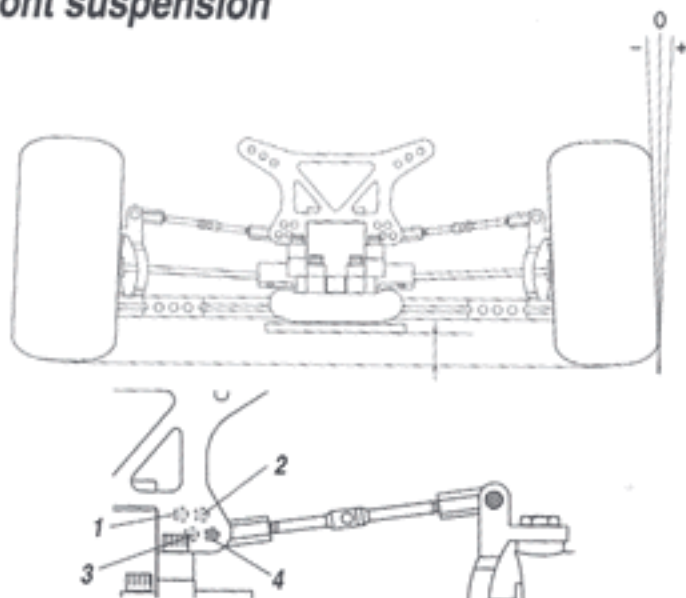

Ride height \_\_\_\_\_ mm  
 Camber angle \_\_\_\_\_ °  
 Caster angle  12°  9.5°  7°  
 Toe angle in/out \_\_\_\_\_ °  
 Rebound \_\_\_\_\_ mm  
 Upper arm position \_\_\_\_\_  
 Anti-roll bar \_\_\_\_\_ ø

## Front shocks

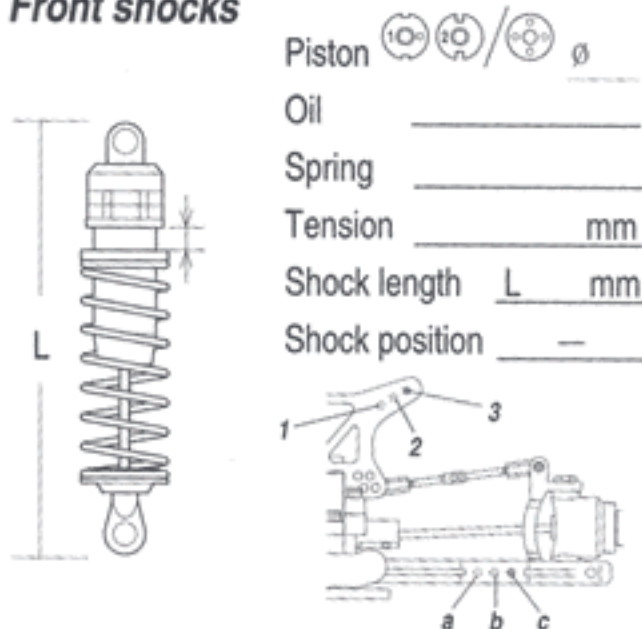

Piston  100  200 /  300 ø \_\_\_\_\_  
 Oil \_\_\_\_\_  
 Spring \_\_\_\_\_  
 Tension \_\_\_\_\_ mm  
 Shock length L mm  
 Shock position \_\_\_\_\_

## Rear suspension

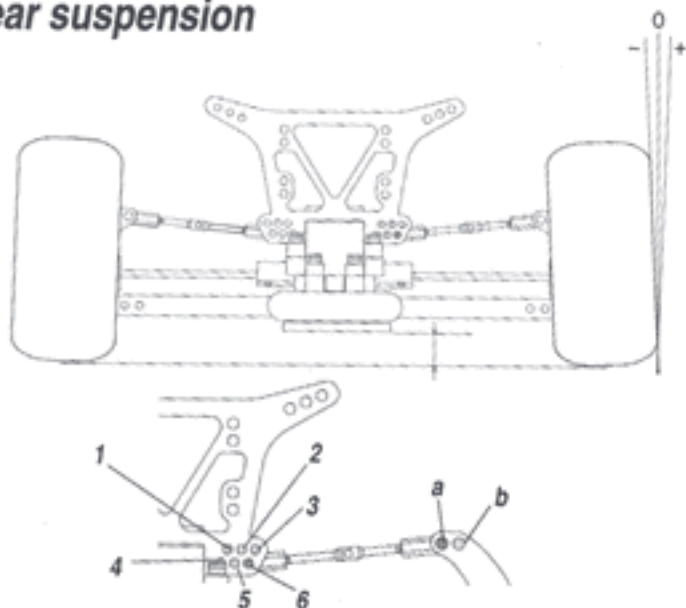

Ride height \_\_\_\_\_ mm  
 Camber angle \_\_\_\_\_ °  
 Anti-squat \_\_\_\_\_ °  
 Rebound \_\_\_\_\_ mm  
 Upper arm position \_\_\_\_\_  
 Anti-roll bar \_\_\_\_\_ ø  
 Toe angle 2° \_\_\_\_\_ °

## One way

Center  
 Yes  No

## Rear shocks

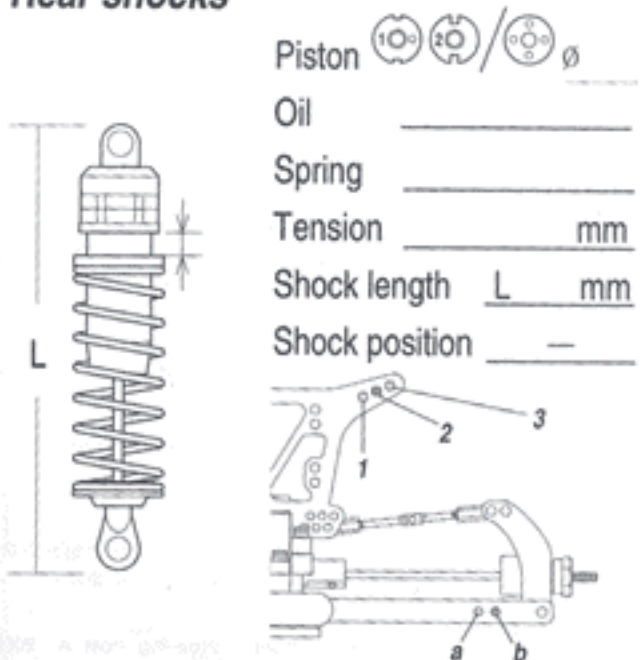

Piston  100  200 /  300 ø \_\_\_\_\_  
 Oil \_\_\_\_\_  
 Spring \_\_\_\_\_  
 Tension \_\_\_\_\_ mm  
 Shock length L mm  
 Shock position \_\_\_\_\_

## Steering

Steering rink position \_\_\_\_\_  
 Steering servo \_\_\_\_\_  
 Steering speed \_\_\_\_\_ %  
 Steering curve \_\_\_\_\_ %

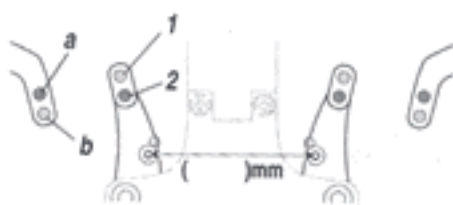

## Wing

Wing \_\_\_\_\_  
 Wing angle \_\_\_\_\_

## Slipper

Yes  No

## Tires & Wheels

Front Tire \_\_\_\_\_ Rear Tire \_\_\_\_\_  
 Insert \_\_\_\_\_ Insert \_\_\_\_\_  
 Wheel \_\_\_\_\_ Wheel \_\_\_\_\_

## Result

Race time / Lap \_\_\_\_\_  
 Best lap (1Lap) \_\_\_\_\_

Motor \_\_\_\_\_ T/ \_\_\_\_\_

ESC \_\_\_\_\_

Battery \_\_\_\_\_ mA

Drive ratio S T/P T x 2.75 = \_\_\_\_\_

Brake \_\_\_\_\_ %  
 ABS  Yes  No  
 Matched  Yes  No

## Overall drive ratio

Pinion	Sptr	62T	65T	67T	70T	72T
161						12.375
171						11.645
18T					10.69	11.00
19T					10.13	10.42
20T					9.62	9.90
21T				8.77	9.16	9.42
22T				8.375	8.75	9.00
23T			7.77	8.01	8.36	8.60
24T			7.44	7.67	8.02	8.25
25T			7.15	7.37	7.70	7.92
26T			6.87	7.08	7.40	7.61
27T	6.31	6.62	6.82	7.12	7.33	
28T	6.08	6.38	6.58	6.87	7.07	
29T	5.87	6.16	6.35	6.63	6.82	
30T	5.68	5.95	6.14	6.14	6.60	

## Comments

A WEB SITE FOR THE SERIOUS RACER