

COMPETITION GRADE HIGH PERFORMANCE RADIO CONTROL RACING CAR CHASSIS KIT

WILDFIRE

1/10 4WD ELECTRIC COMPETITION TOURING CAR KIT

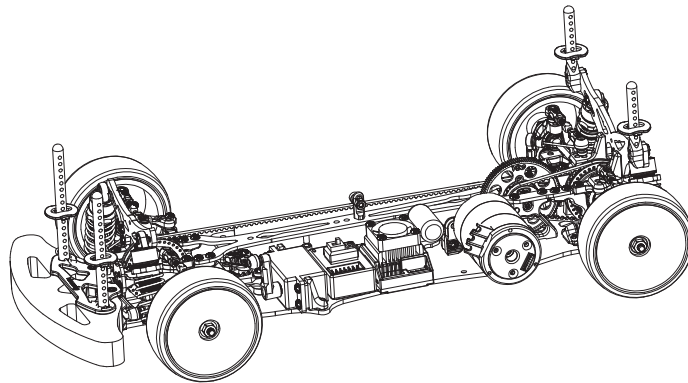

INSTRUCTIONS MANUAL

vbc racing

E

Thank you for purchasing VBC Racing product.

Things that we should remind you.

This VBC Racing kit is a high performance, racing grade car kit intended for experienced racers. The kit compose of VBC formulated composite materials, top quality full carbon fiber chassis and high grade 7075 material which will give you a competitive edge over the others.

Novice racer should seek advice from more experienced racer before assembly.

Always keep this instruction manual handy at all times for quick reference even after completing the assembly.

Before your assembly, sand the chassis edges.

Sand the chassis edges with #600 sand paper and apply CA glue to the edges and counter sink holes.

Need help or support.

If you need help or you would like to leave us a comment, please email to our support team: support@vbc-racing.com or visit our web site www.vbcrc.com

Competition X
A WEB SITE FOR THE SERIOUS RACER



1

Graphite Edges Protection Procedure



*Not included in this kit

Sand the chassis edges with #600 sand paper(not included) and apply CA glue(not included) to the edges of the chassis.

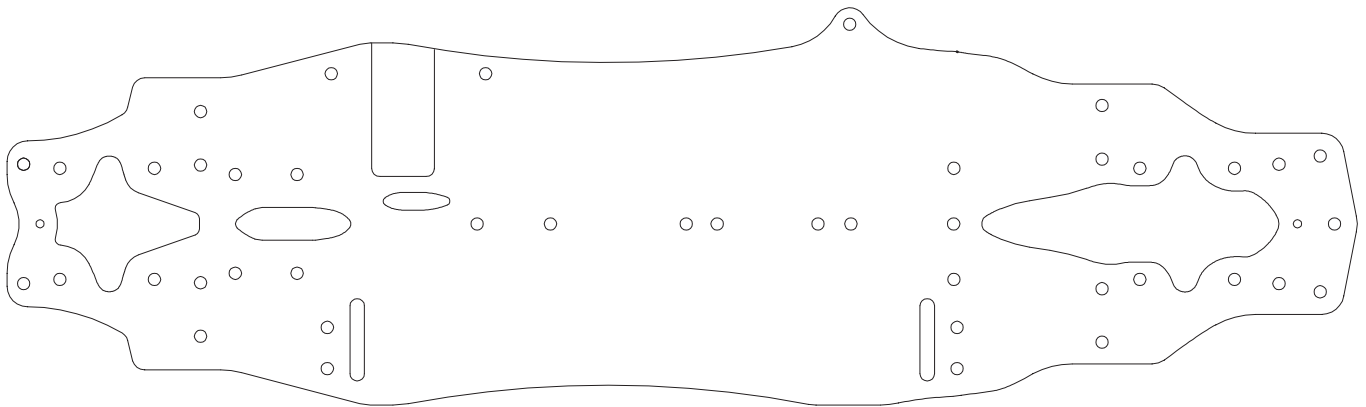

A-01-VBC-0035-25 WildFire Standard Graphite Chassis

Sand the below graphite edges with #600 sand paper and apply CA glue to the edges.

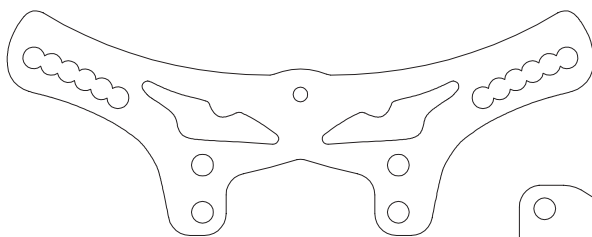

A-01-VBC-0027 WildFire Graphite Front Shock Tower

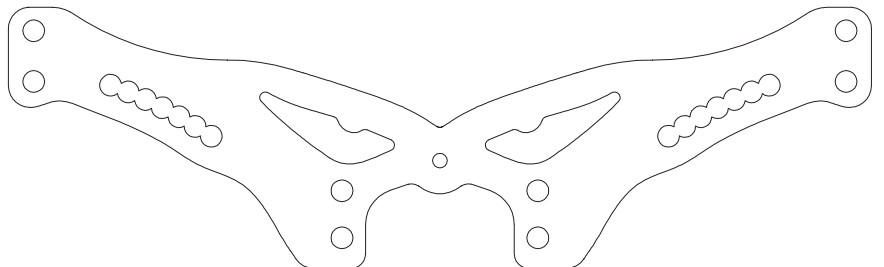

A-01-VBC-0028 WildFire Graphite Rear Shock Tower

Competition X
A WEB SITE FOR THE SERIOUS RACER

2

Rear Gear Diff Assembly

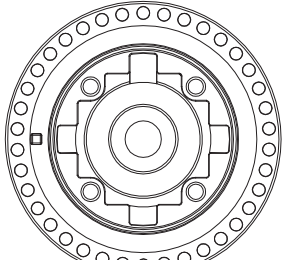

Gear Diff Housing A-03-VBC-0016 x 1

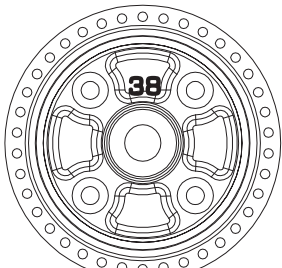

Gear Diff Pulley 38T A-03-VBC-0017 x 1

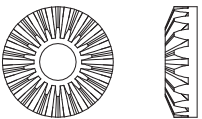

Diff Gear 18T A-03-VBC-0019 x 2



Diff Cup B-02-VBC-0022 x 2

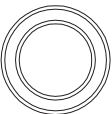

10x15 Ball Bearing C-02-BB-1510-B x 2

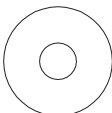

15x0.3 Shim B-02-VBC-0077 x 2



M2x10 Shaft Pin B-02-VBC-0020 x 2



Diff Shaft Sealer O-Ring B-03-VBC-0006 x 2

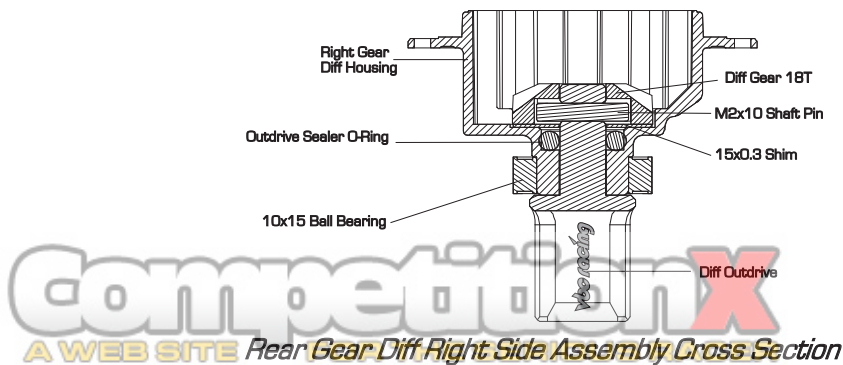
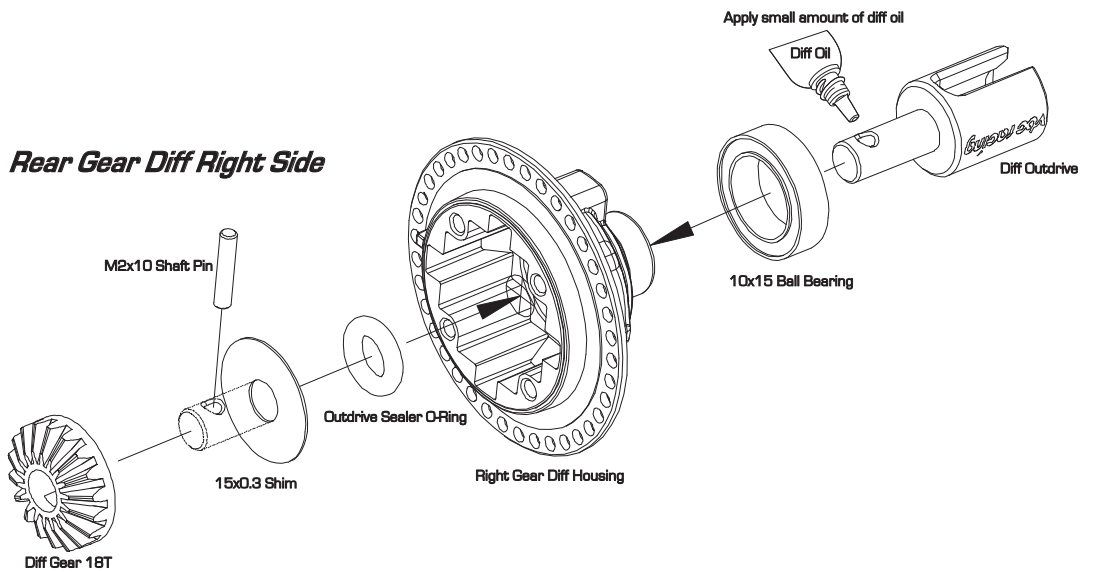
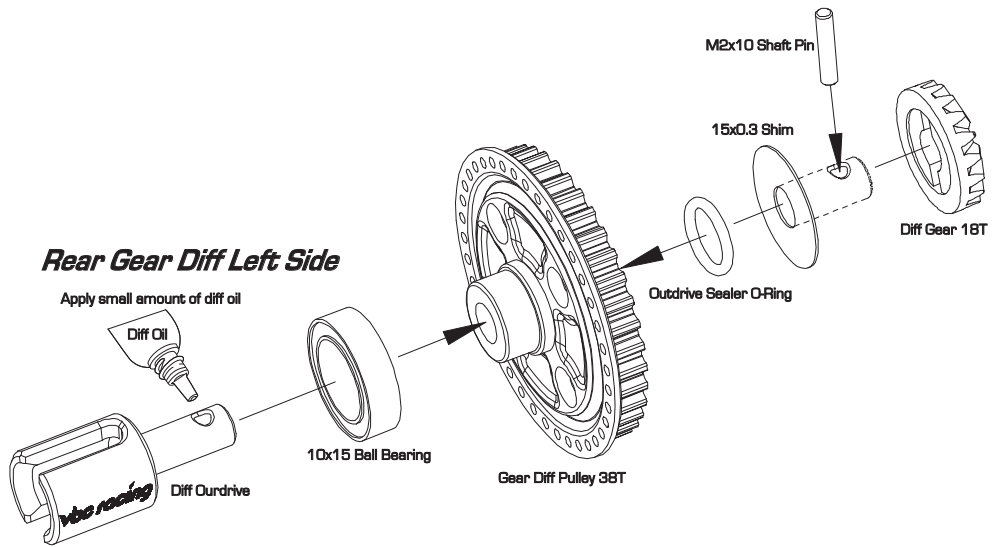

3

Rear Gear Diff Assembly Continue

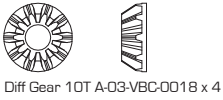

Diff Gear 10T A-03-VBC-0018 x 4



9.5x0.2mm Shim B-02-VBC-0078 x 4



M2.6x10 Flathead Screw C-02-SC-F2.6x10 x 4

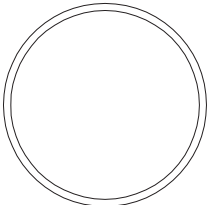

Diff Housing Sealer O-Ring B-03-VBC-0005 x 1

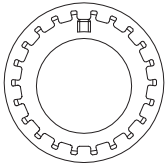

Belt Tension Adjuster Ring A-03-VBC-0047 x 2

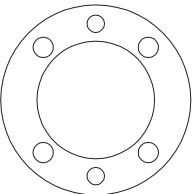

Seal Gasket B-03-VBC-0004 x 1

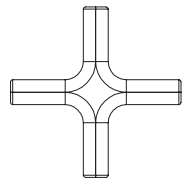

Diff Gear Shaft A-03-VBC-0020 x 1

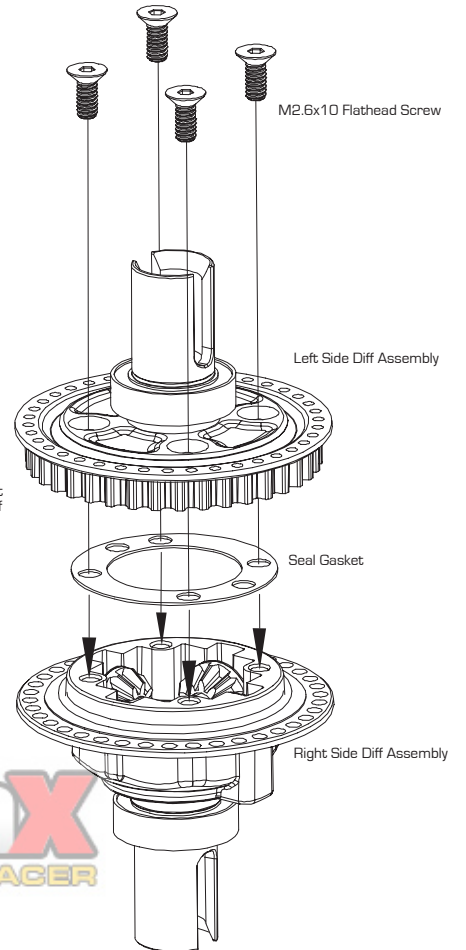
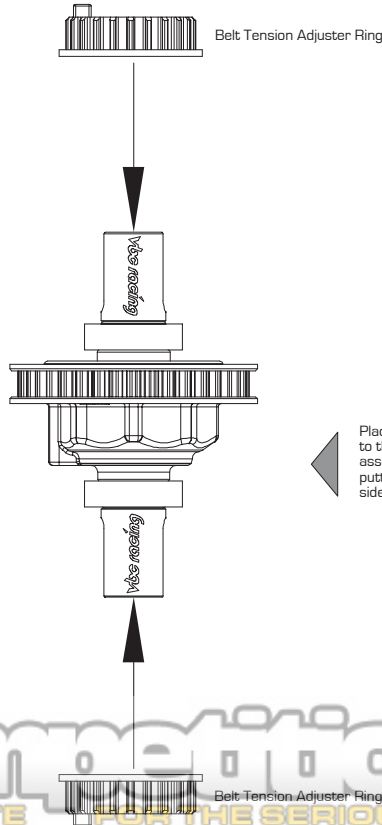
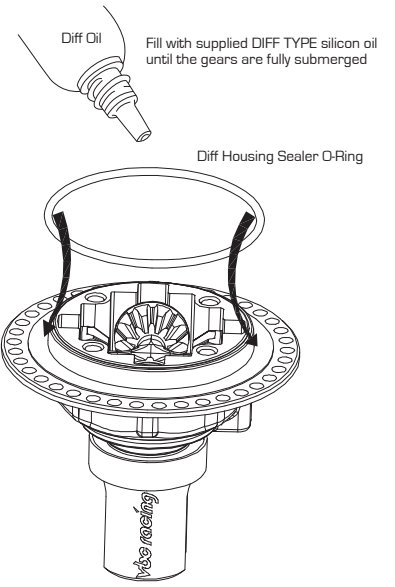
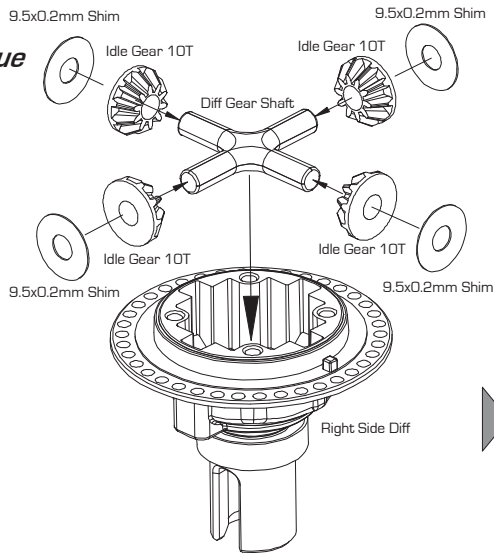

Competition X
A WEB SITE FOR THE SERIOUS RACER

4

Rear Drivetrain Assembly

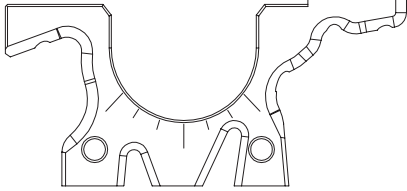

Lower Bulkhead A B-02-VBC-0057 x 1

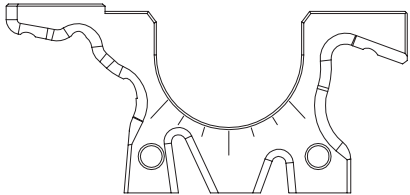

Lower Bulkhead B B-02-VBC-0090 x 1

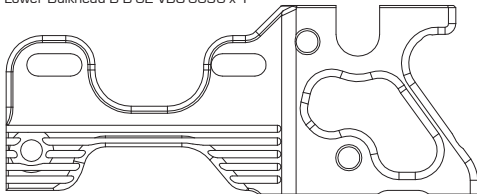

Motor Mount B-02-VBC-0058 x 1

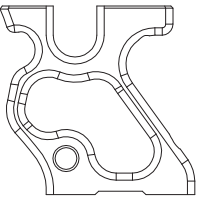

Main Gear Bulkhead B-02-VBC-0059 x 1



Center Suspension Mount x 2
B-02-VBC-0062



Motor Mount Support B-02-VBC-0067 x 1



Center Suspension Mount Shim(1mm) x 2
A-01-VBC-0038



M3x8 Flathead C-02-SC-F0308 x 1



M3x6 Flathead C-02-SC-F0306 x 13

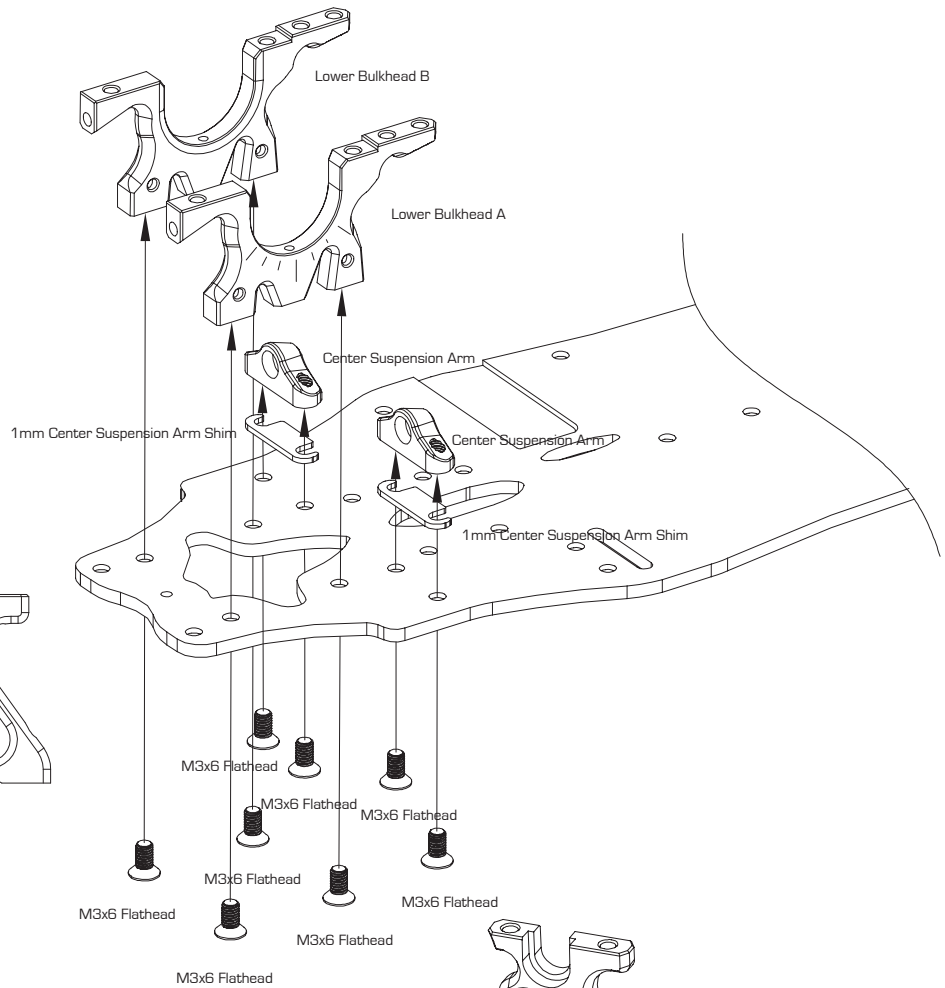

5

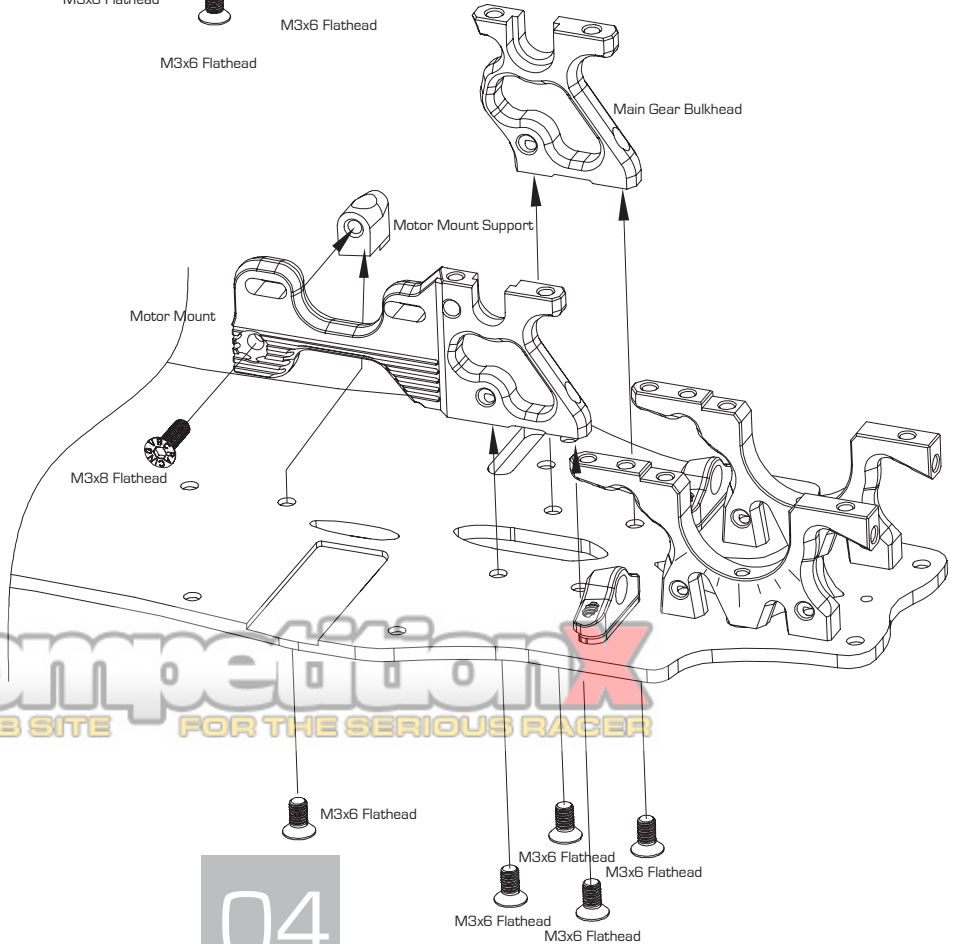

Competition
A WEB SITE FOR THE SERIOUS RACER

6

Front Drive Train Assembly

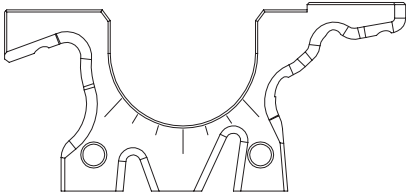

Lower Bulkhead A B-02-VBC-0057 x 1

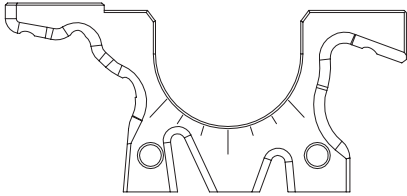

Lower Bulkhead B B-02-VBC-0090 x 1



Center Suspension Arm B-02-VBC-0062 x 2

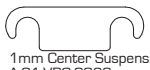

1mm Center Suspension Arm Shim x 2
A-01-VBC-0038



Battery Adjust Top Plate x 1
B-02-VBC-0072



M3x8 Flathead C-02-SC-F0308 x 2



M3x6 Flathead C-02-SC-F0306 x 8



Battery Position Slider A-01-VBC-0033 x 1

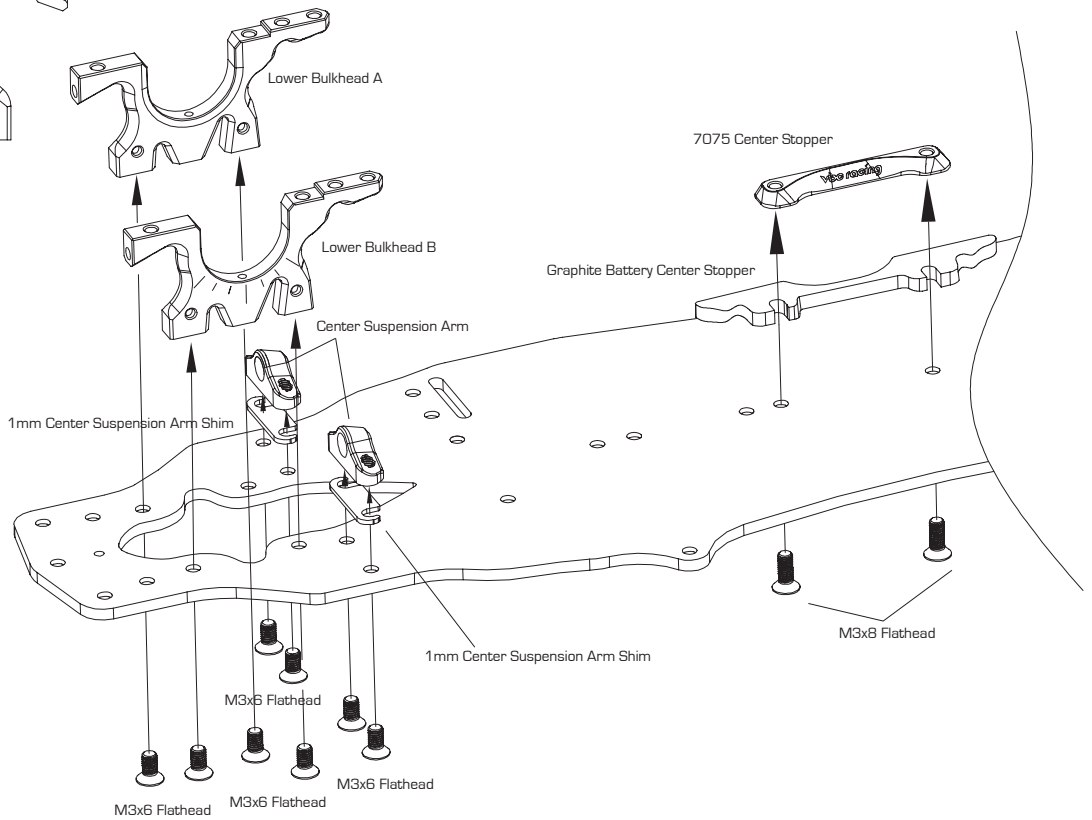

CompetitionX
A WEB SITE FOR THE SERIOUS RACER

7

Steering System Assembly

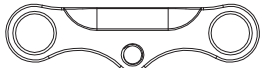

Steering Assembly Travel Plate B-02-VBC-0054 x 1

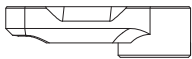

Steering Travel Arm B-02-VBC-0053 x 2



Steering Assembly Pole B-02-VBC-0055 x 2



Ball Connector B-02-VBC-0045 x 3



5x8 Ball Bearing C-02-BB-0805-B x 4



3x6 Ball Bearing C-02-BB-0603 x 2



Steering Cone Washer B-02-VBC-0089 x 2



T2 7075 Spacer B-02-VBC-0019-20 x 2



T1 7075 Spacer B-02-VBC-0019-10 x 2



M3x6 Roundhead C-02-SC-R0306 x 4



M3x6 Set Screw C-02-SC-SS-0306 x 1



M3x10 Set Screw C-02-SC-SS-0310 x 2



M3x42mm Turnbuckle B-02-VBC-0037 x 2



M3x18mm Turnbuckle B-02-VBC-0038 x 1



Turnbuckle Cup A-03-VBC-0039 x 6

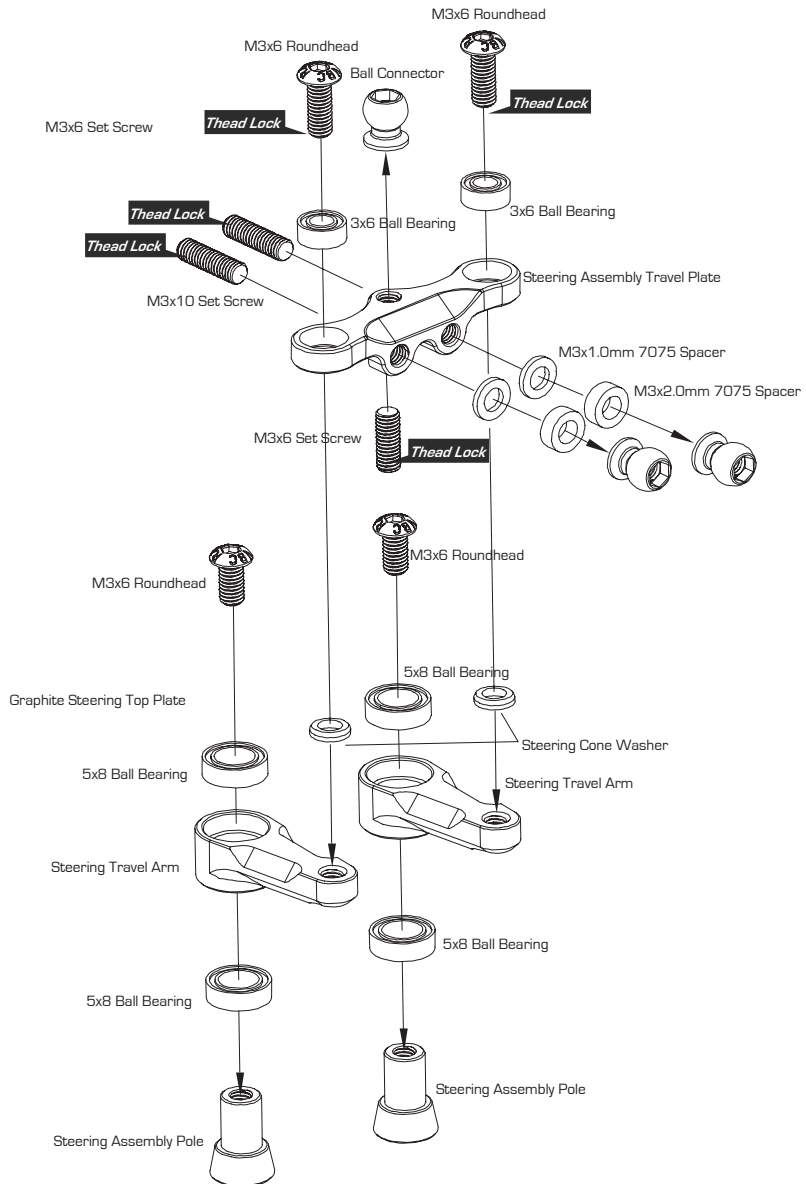

8

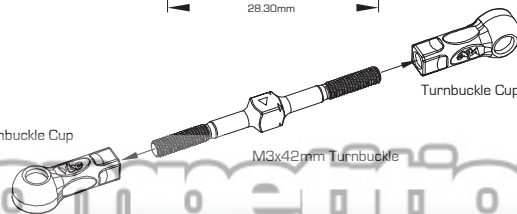
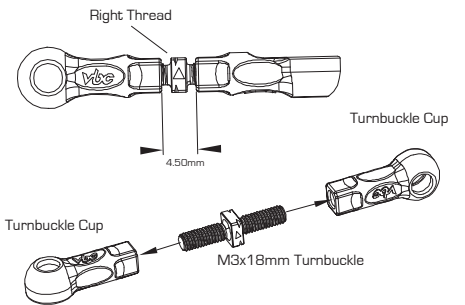
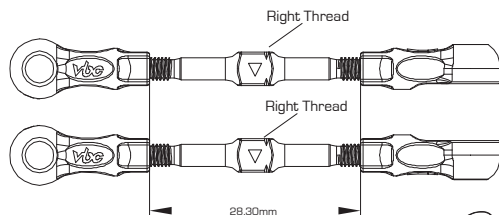

Make 1 servo link tie-rod, follow the connector cups directions as the above diagram. The connector cups edge to edge shall be 4.50mm. Please use a caliper to measure the exact measurement.

Make 2 steering link tie rods, follow the connector cups directions as the above diagram. The connector cups edge to edge shall be 28.20mm. Please use a caliper to measure the exact measurement.

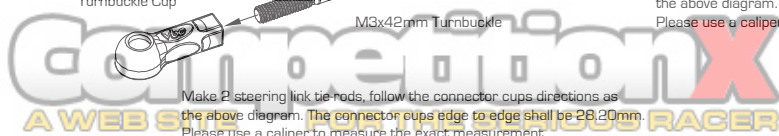

9

Steering System Assembly



M3x6 Flathead C-02-SC-F0306 x 2

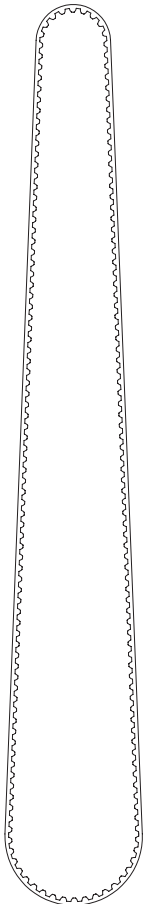

Front Belt Type SS A-03-VBC-0048-512 x 1

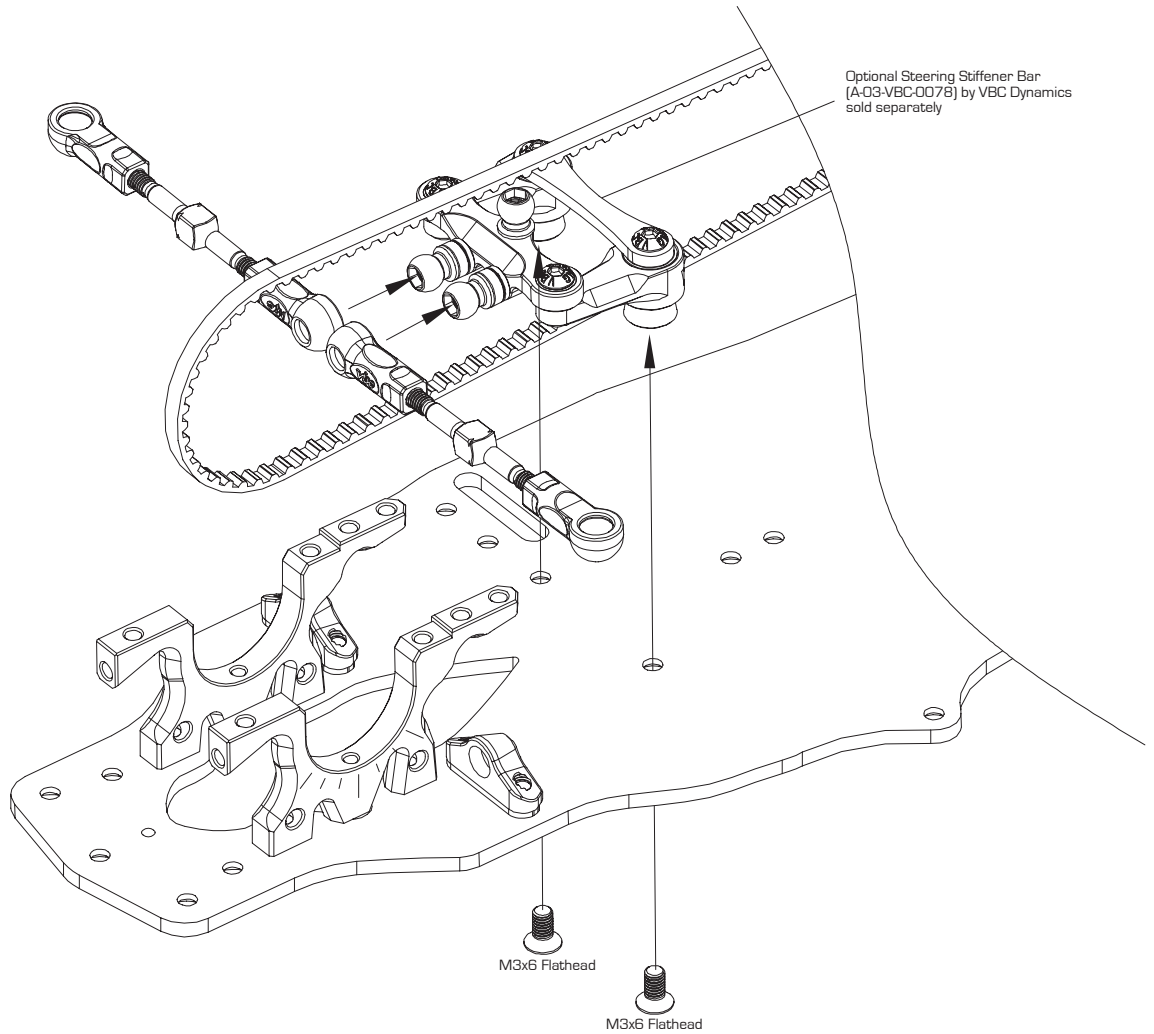

Install the steering unit onto the main chassis with two M3x6 Flathead Screws. Then attach the left and right tie rods to the steering unit. Make sure the front belt is between the two Steering Assembly Poles.

CompetitionX
A WEB SITE FOR THE SERIOUS RACER

10

Upper Deck Assembly



Belt Tensioner B-02-VBC-0069 x 1



3x6mm Ball Bearing C-02-BB-0603 x 2



3x5x0.5mm Shim B-02-VBC-0093 x 3



M3x12 Roundhead Screw C-02-SCR-0312 x 1



M3x4 Roundhead Screw C-02-SCR-0304 x 1



M3 Lock Nut C-02-SC-NN03 x 1

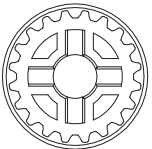

20T Center Pulley A-03-VBC-0023 x 2

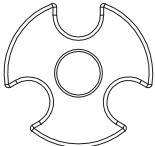

Center Pulley Spacer A-03-VBC-0060 x 1

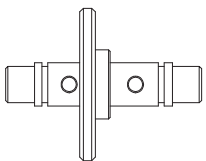

Center Pulley Drive Shaft B-02-VBC-0087 x 1



5x8mm Ball Bearing C-02-BB-0805-B x 2



M3x4 Round Head Screw C-02-SCR-0304 x 3



M3x6 Set Screw x 2
C-02-SS-0306



M2x12 Shaft Pin B-02-VBC-0020 x 2



M5x11 E-Clip B-02-VBC-0085 x 2

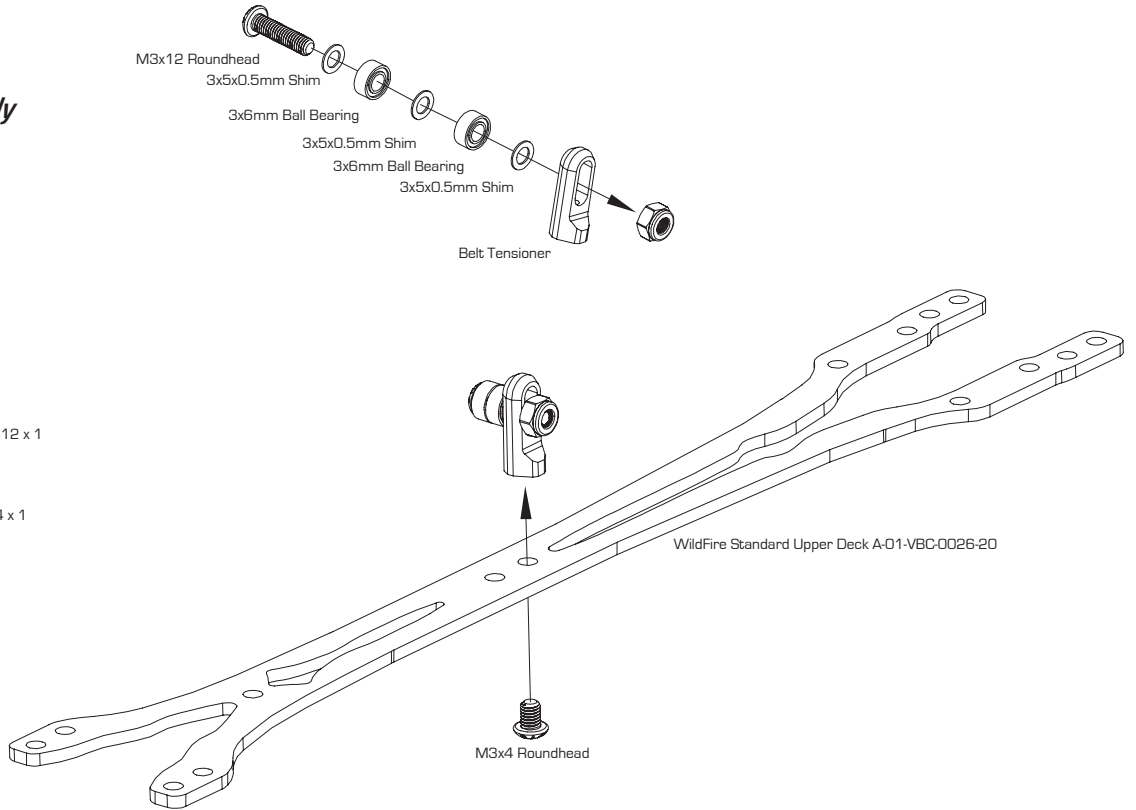

11

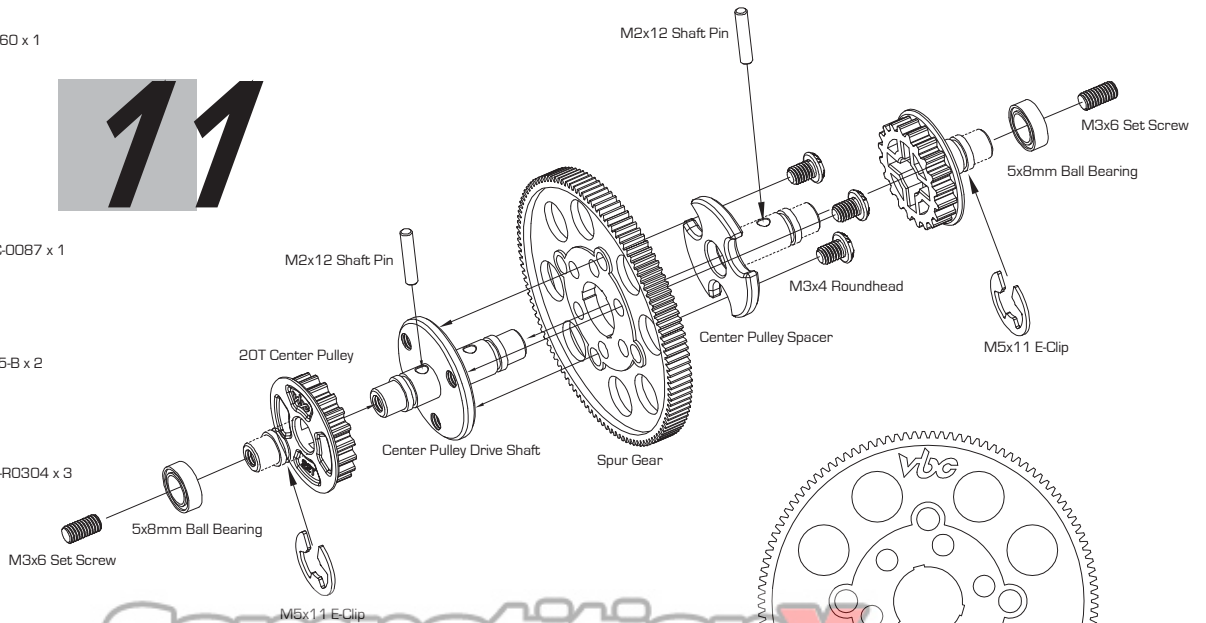

Competition
A WEB SITE FOR THE SERIOUS RACER

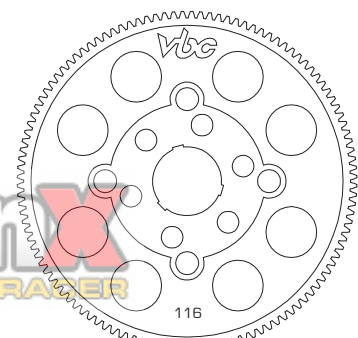

64P Spur Gear 116T A-03-VBC-SG-116 x 1

12

Upper Deck Assembly



M3x6 Roundhead C-02-SC-R0306 x 12



M3x8 Flathead C-02-SC-F0308 x 1

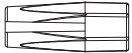

Antenna Stand A-03-VBC-0059 x 1

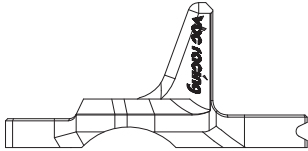

Upper Bulkhead A B-02-VBC-0063 x 1

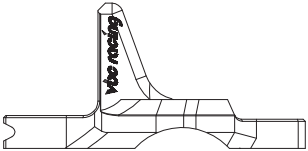

Upper Bulkhead B B-02-VBC-0064 x 1



Ball Connector B-02-VBC-0045 x 2



T2 7075 Spacer B-02-VBC-0019-20 x 2



M3x10 Set Screw C-02-SC-SS-0310 x 2

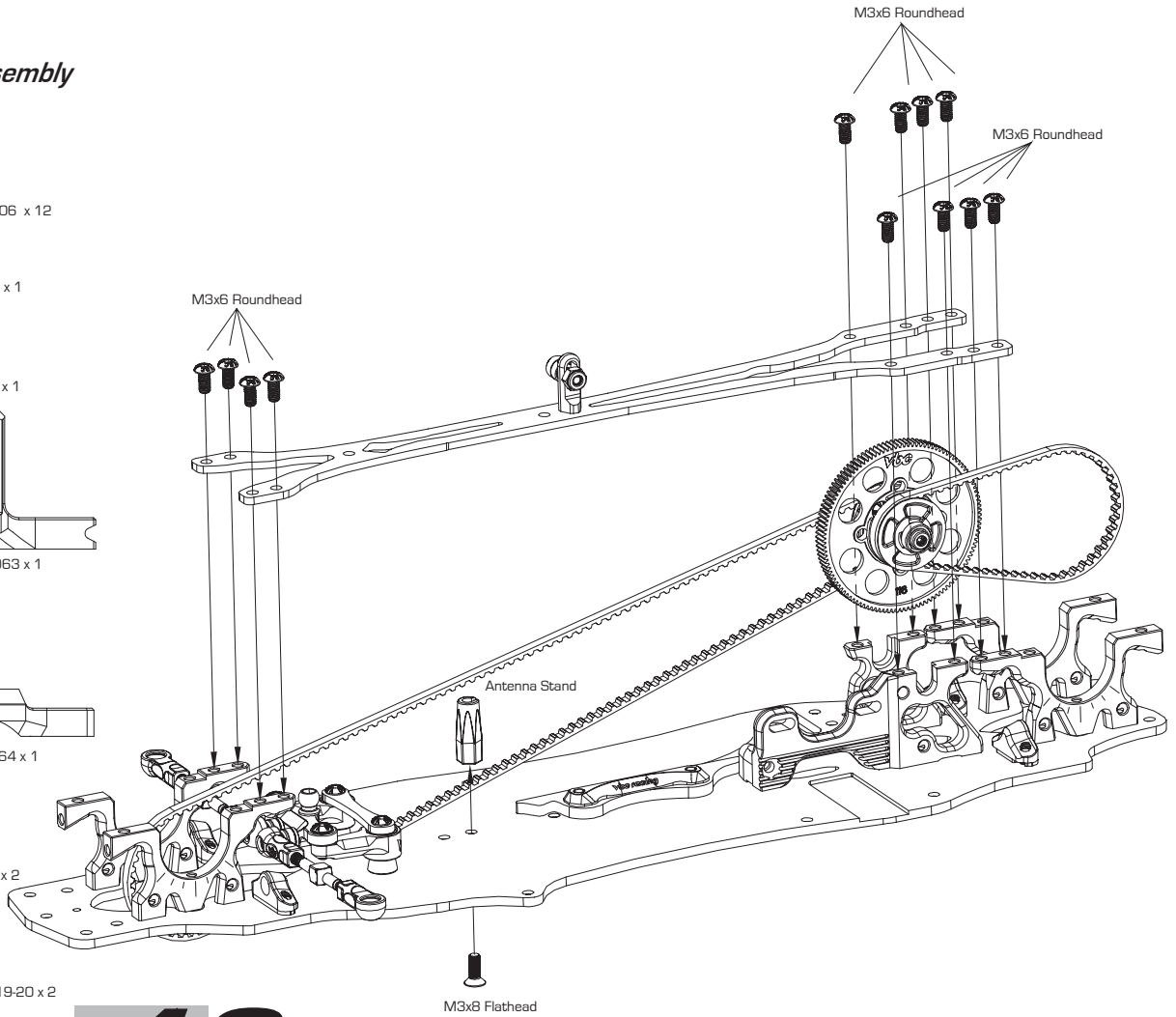

13

Rear Upper Bulkhead Assembly

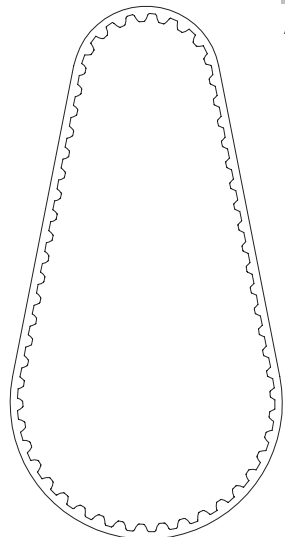

Rear Belt Type SS A-03-VBC-0048-177 x 1

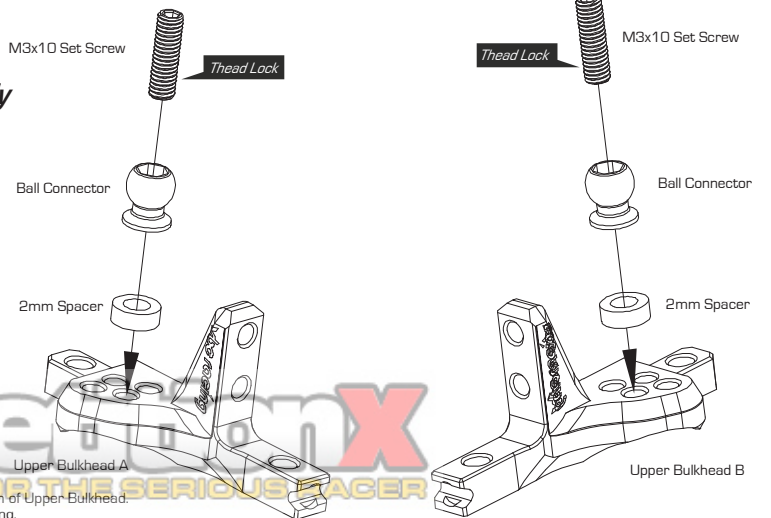

Be careful not to overthread the set screw.
 The set screw should not over the edge of the bottom of Upper Bulkhead.
 Overthreading may obstruct the drive hub from spinning.

14

Install Rear Drivetrain

 M3x8 Roundhead C-02-SC-R0308 x 4

 M2x10 Roundhead C-02-SC-R2.0x10 x 2

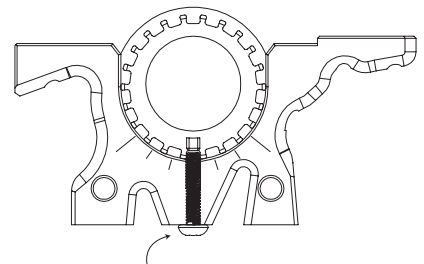
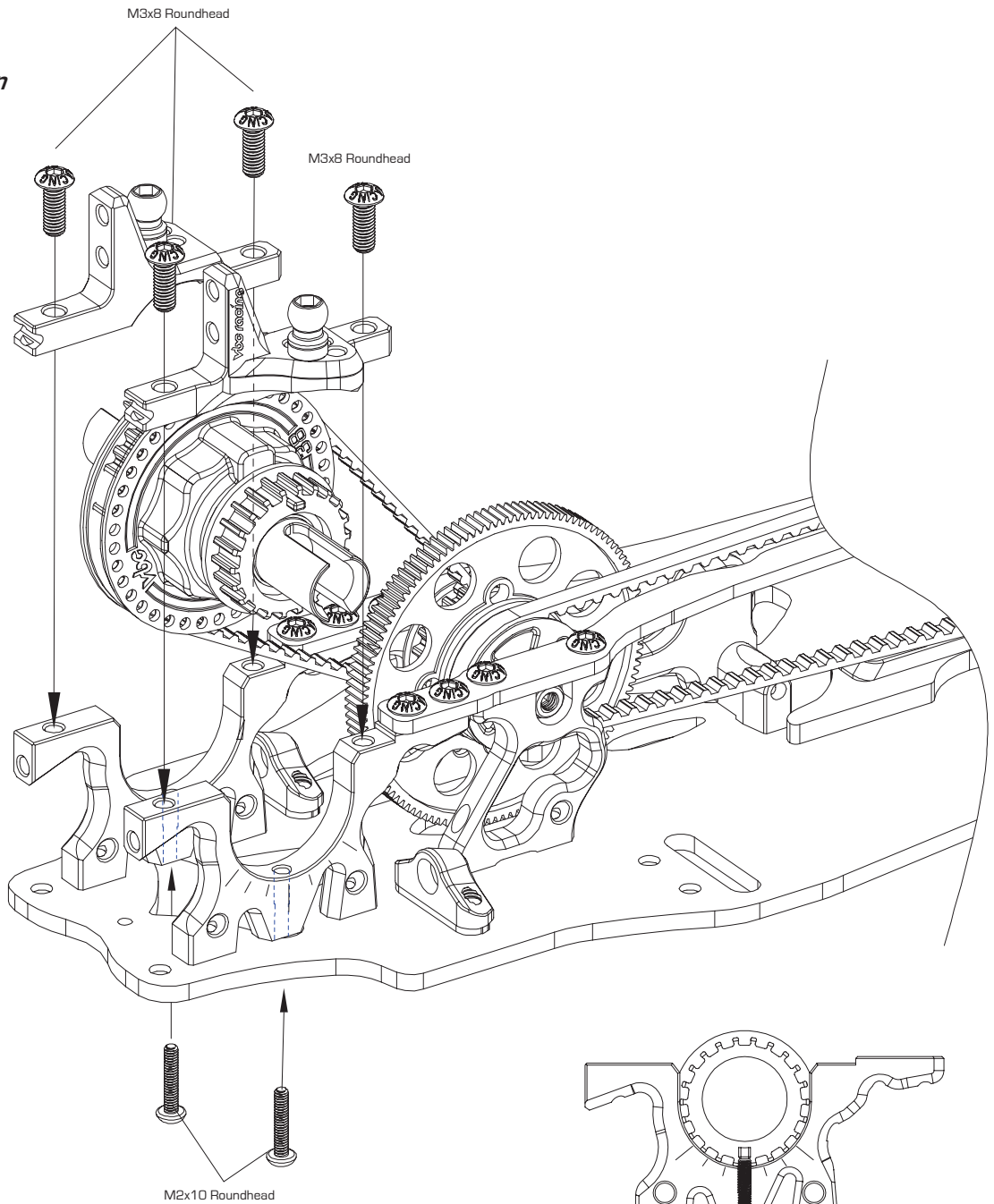

Tighten screw to lock the Belt Tension Adjuster Ring position

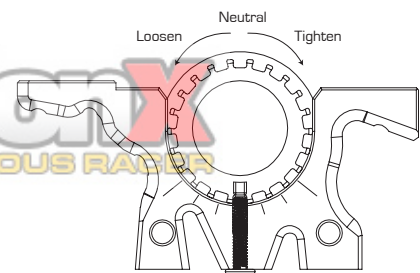

Tighten or loosen the belt tension by adjusting the Belt Tension Adjuster Ring dial

Competition
A WEB SITE FOR THE SERIOUS RACER

15

Front Drive Train Assembly - Spool Assembly

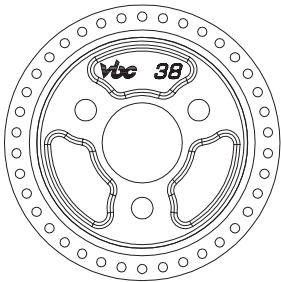

Front Spool 38T A-03-VBC-0021 x 1

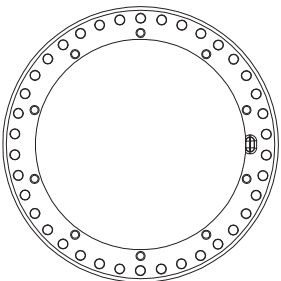

Pulley Belt Guide A-03-VBC-0022 x 1

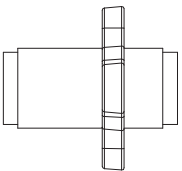

Spool Drive Shaft A-03-VBC-0049 x 1

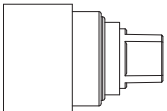

Front Spool Outdrive A-03-VBC-0055 x 2

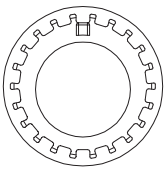

Belt Tension Adjuster Ring A-03-VBC-0047 x 2

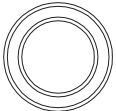

10x15 Ball Bearing C-02-BB-1510-B x 2



M3x12 Flathead C-02-SC-F0312 x 2



M3x6 Roundhead C-02-SC-R0306 x 3

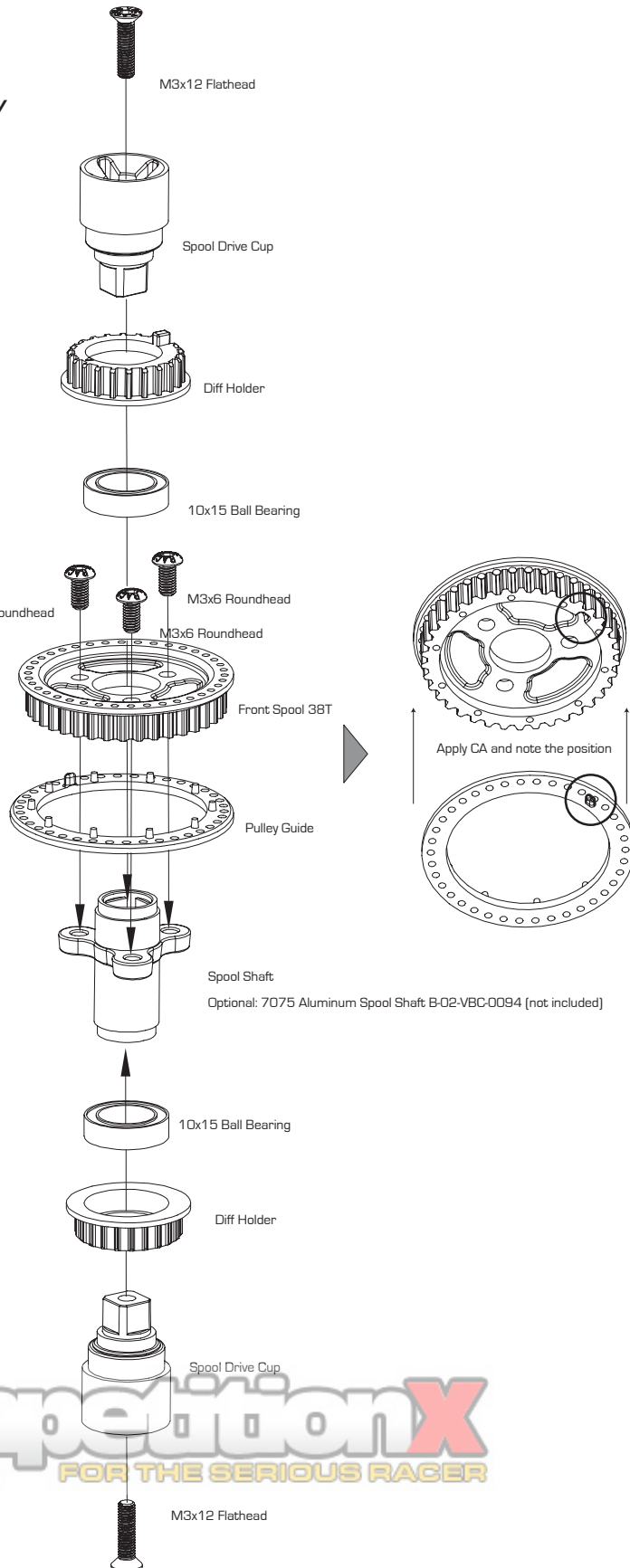

Competition X
A WEB SITE FOR THE SERIOUS RACER

16

Assemble Front Upper Bulkhead

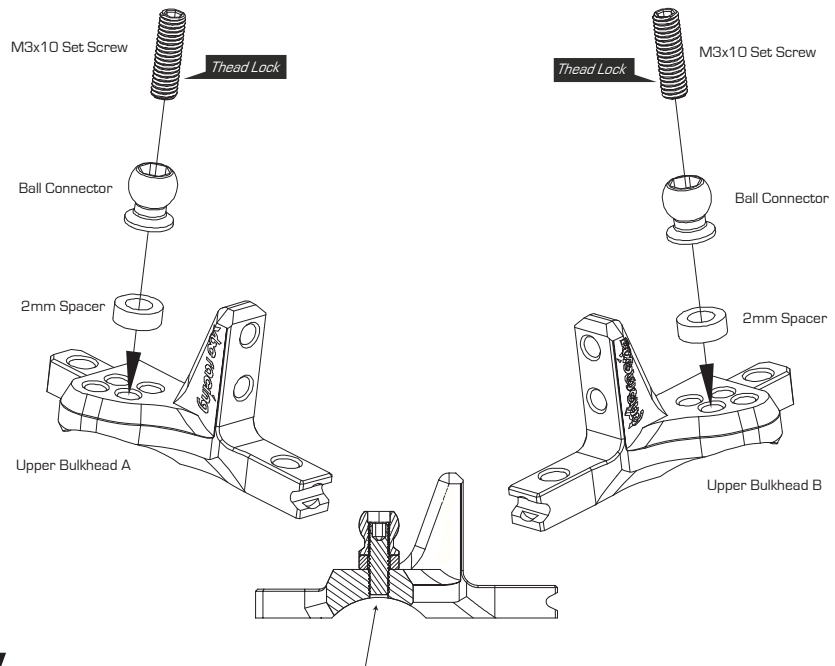
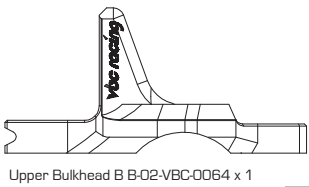
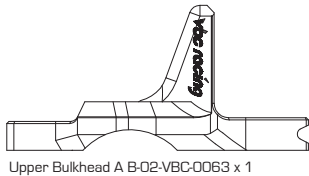

Be careful not to overthread the set screw. The set screw should not over the edge of the bottom of Upper Bulkhead. Overthreading may obstruct the drive hub from spinning.

17

Install Front Drivetrain

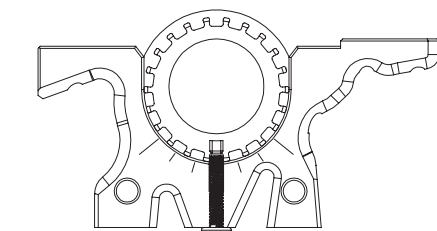

Tighten screw to lock the Belt Tension Adjuster Ring position

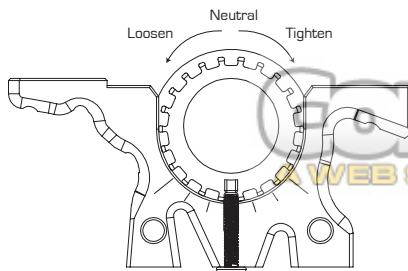

Tighten or loosen the belt tension by adjusting the Belt Tension Adjuster Ring dial

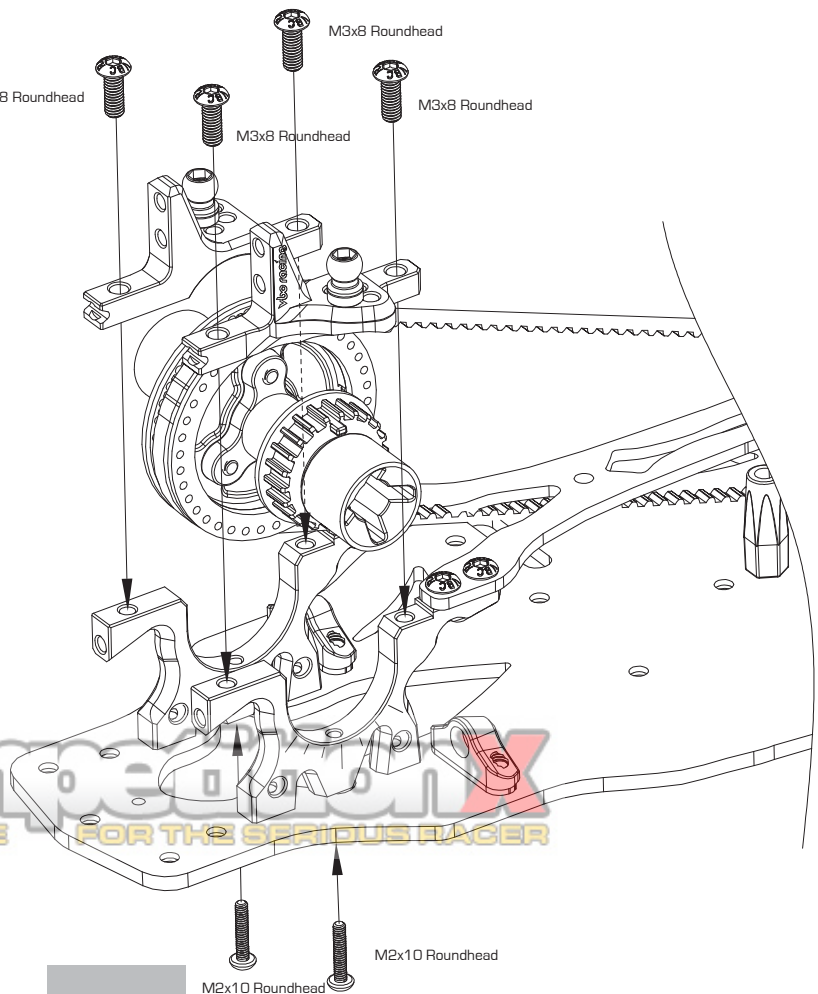

COMPETITION
WEB SITE FOR THE SERIOUS RACER

18

Rear Suspension Arm Assembly

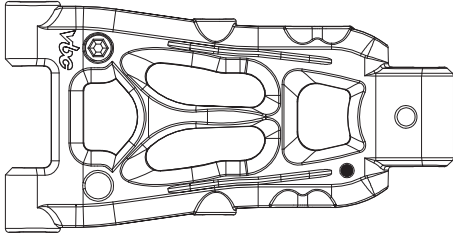

Rear Suspension Arm A-03-VBC-0050 x 2



Suspension Arm Spacer T2 Composite A-03-VBC-0052 x 2



Suspension Arm Spacer T1 Composite A-03-VBC-0051 x 4



Suspension Arm Pin B-02-VBC-0029 x 2



Ball Connector B-02-VBC-0045 x 4



Arm Pin Pivot Ball B-02-VBC-0035 x 2



M4x10 Set Screw C-02-SC-SS-0410 x 2



M3x10 Set Screw C-02-SC-SS-0310 x 4



E30 Suspension Mount B-02-VBC-0061-30 x 1



1mm Suspension Shim A-01-VBC-0037 x 1



M3x6 Flat Head Screw C-02-SC-F0306 x 2

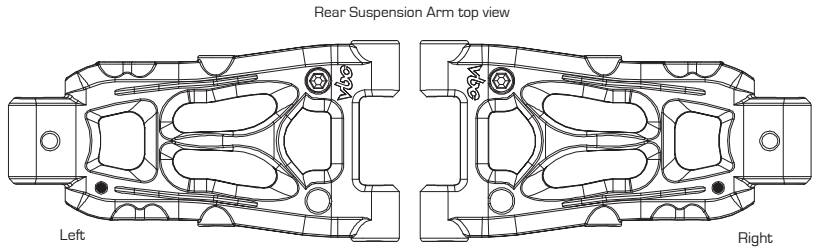

Left

Right

Make sure the black markings are in the same direction on the left and right suspension arms

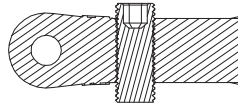

Top

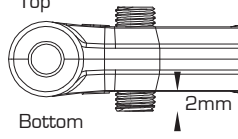

Bottom

2mm

Insert M4x10 Set Screw from the top of the suspension arm for adjusting down stop. Initial setting is 2mm measuring from the bottom part of the arm for both sides.

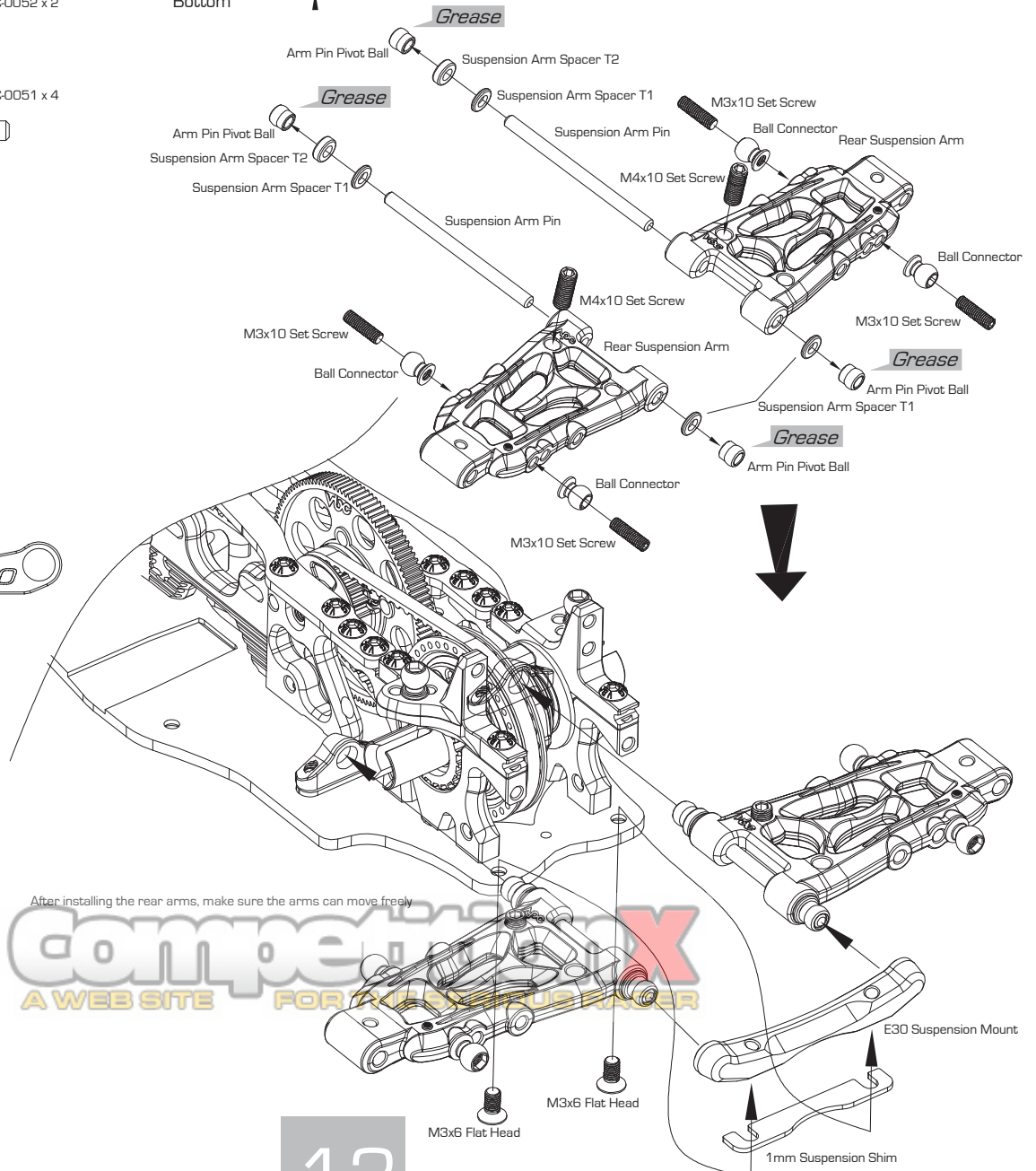

After installing the rear arms, make sure the arms can move freely



19

Rear Suspension Arm Assembly Part 2

Align the Shaft End Shoe to the Inner Axle Pin hole first and slide the 12mm Shaft Pin to the pin hole before securing the pin with M3x2 Set Screw

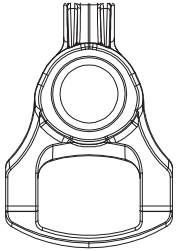

Rear Suspension Upright A-03-VBC-0037 x 2



Shaft End Shoe A-03-VBC-0038 x 2

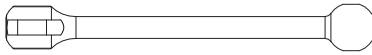

Inner Axle B-02-VBC-0024 x 2

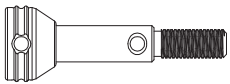

Wheel Axle B-02-VBC-0025 x 2



Axle Joint B-02-VBC-0026 x 2



Axle Lock Spring B-02-VBC-0027 x 2



5x10mm Ball Bearings x 4



M2x12 Shaft Pin B-02-VBC-0020-12 x 2



M2x10 Shaft Pin B-02-VBC-0020 x 4



M3x10 Set Screw C-02-SC-SS-0310 x 2



M3x2 Set Screw C-02-SC-SS-0302 x 2



M1.6x4 Screw C-02-SCR1.6x4 x 2



O Offset Hex Wheel Hub B-02-VBC-0051 x 2



Ball Connector B-02-VBC-0045 x 2



T1 7075 Spacer B-02-VBC-0019-10 x 2

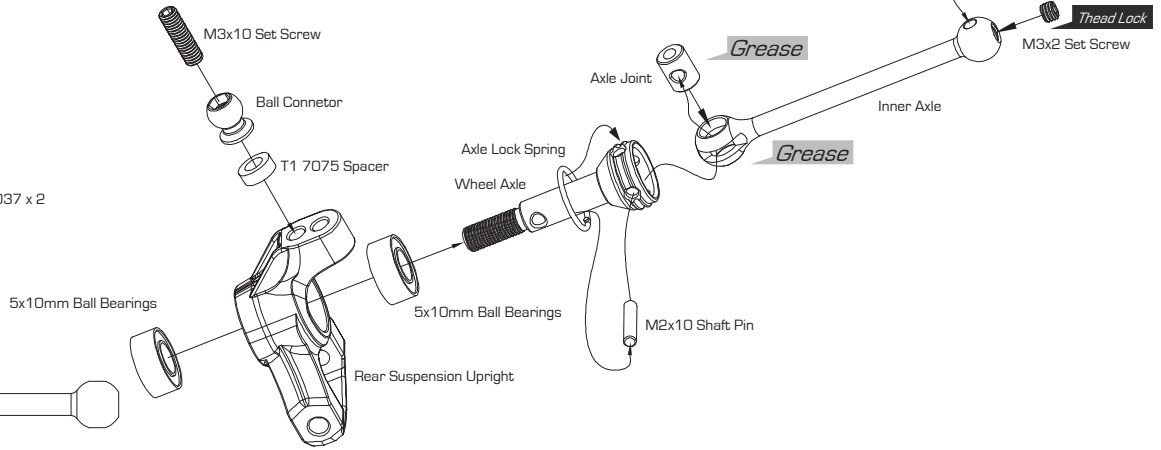

Joint cross section

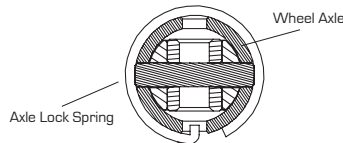

Make sure the Axle Lock Spring is place correctly onto the Wheel Axle

Align the Shaft End Shoe to the Inner Axle Pin hole first and slide the 12mm Shaft Pin to the pin hole before securing the pin with M3x2 Set Screw

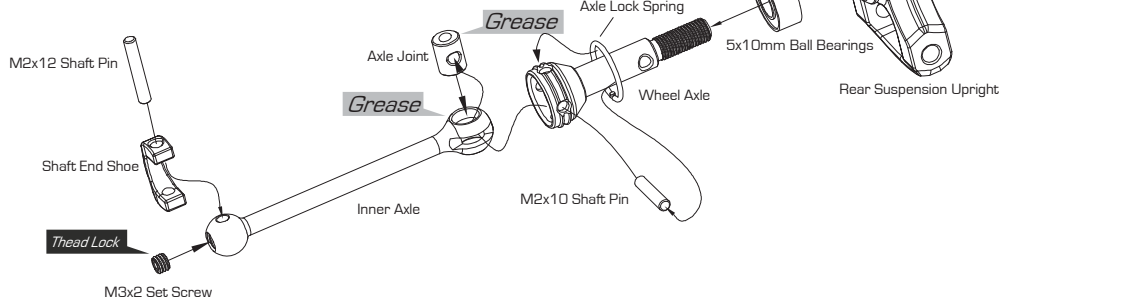

After assembling the drive shaft, make sure the joints are free swinging.

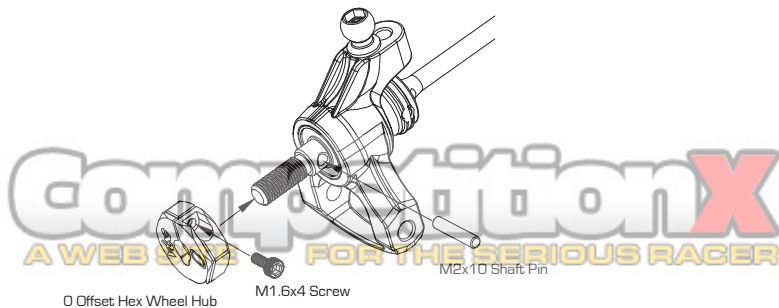

Do not over tighten the M1.6x4 screw to prevent stripping

20

Rear Suspension Arm Assembly Part 3



Turnbuckle Cup A-03-VBC-0039 x 2



Turnbuckle Cup S A-03-VBC-0056 x 2

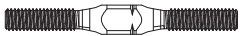

M3x32mm Turnbuckle B-02-VBC-0036 x 2



M3x23 Upright Pin B-02-VBC-0032 x 2



3x5x0.5mm Shim B-02-VBC-0093 x 2



M3x6 Set Screw C-02-SS-0306 x 2

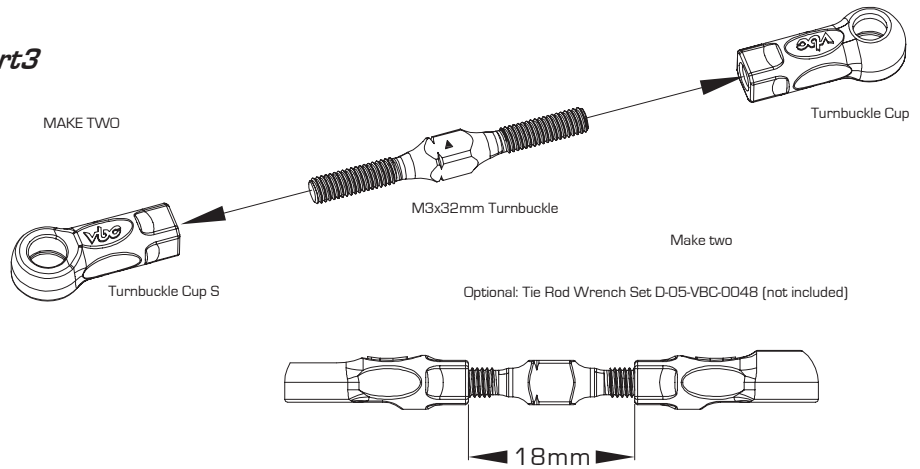

Make sure the turnbuckle caps move freely after snapped to the ball connector

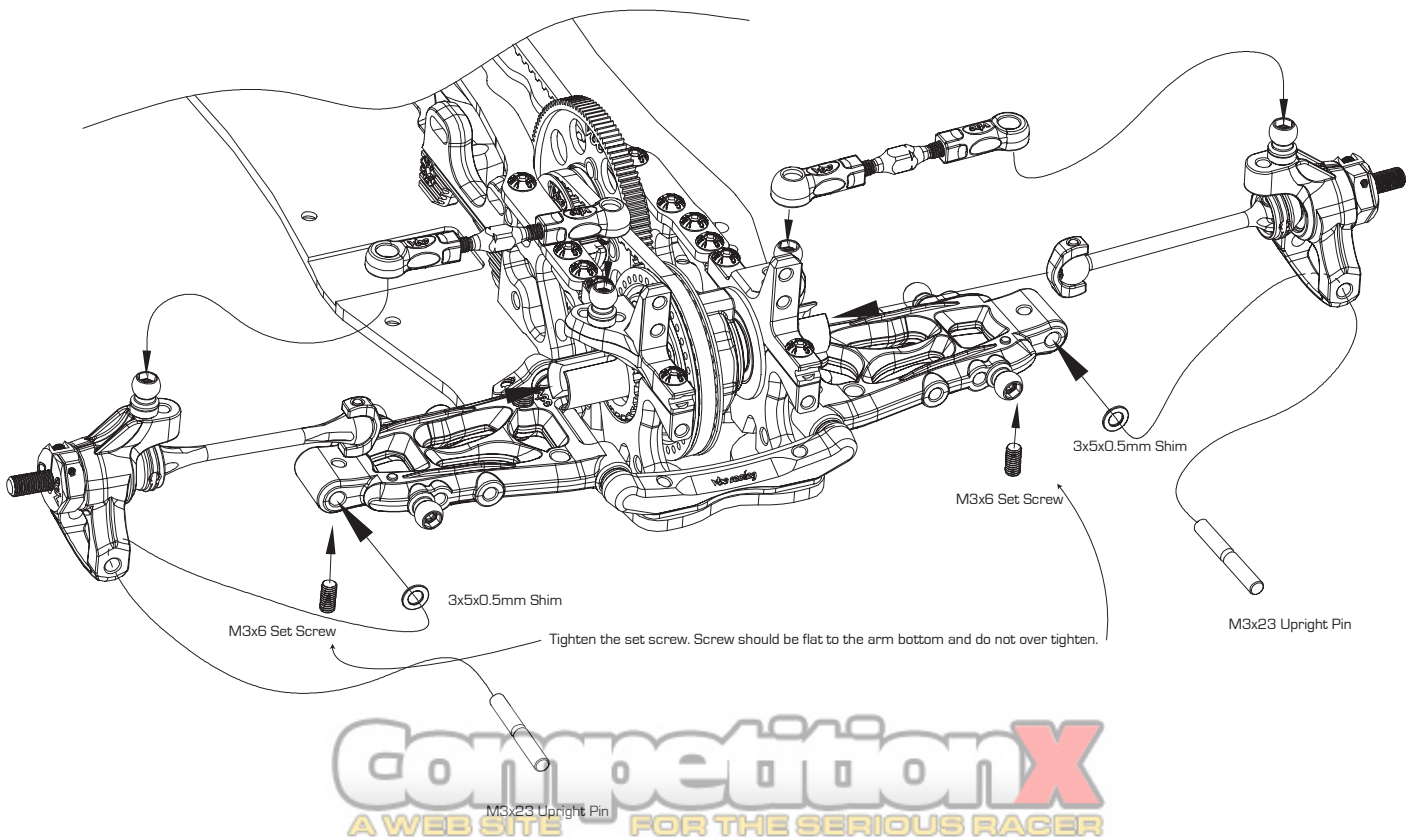

21

Front Suspension Assembly Part 1

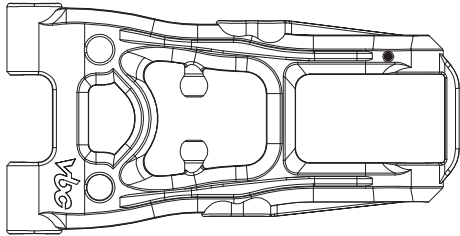

Front Suspension Arm A-03-VBC-0024 x 2

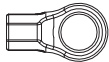
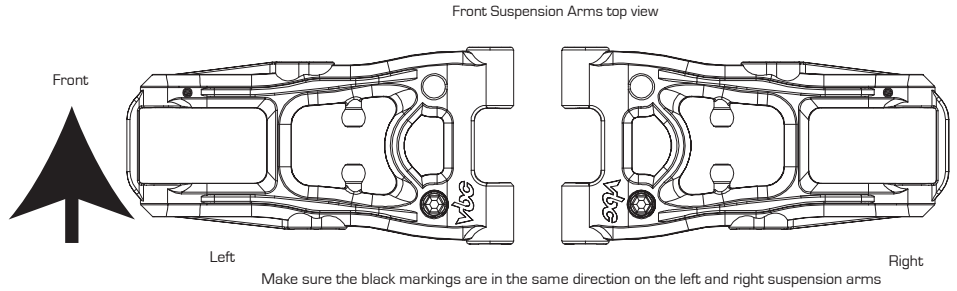

Turnbuckle Cup Open Type L A-03-VBC-0041 x 2



Turnbuckle Cup Open Type S A-03-VBC-0040 x 2



Suspension Arm Spacer T2 A-03-VBC-0052 x 2



Suspension Arm Spacer T1 A-03-VBC-0051 x 4

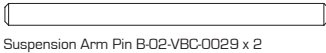

Suspension Arm Pin B-02-VBC-0029 x 2



Ball Connector B-02-VBC-0045 x 4



Arm Pin Pivot Ball B-02-VBC-0035 x 4



M4x10 Set Screw C-02-SC-SS-0410 x 2



M3x10 Set Screw C-02-SC-SS-0310 x 4

Ball Connector Open Type S

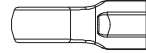

Ball Connector Open Type L

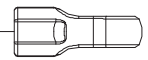

M3x10 Set Screw

Make 2 sets

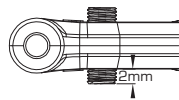

Insert M4x10 Set Screw from the top of the suspension arm for adjusting down stop. Initial setting is 2mm measuring from the bottom part of the arm for both sides.

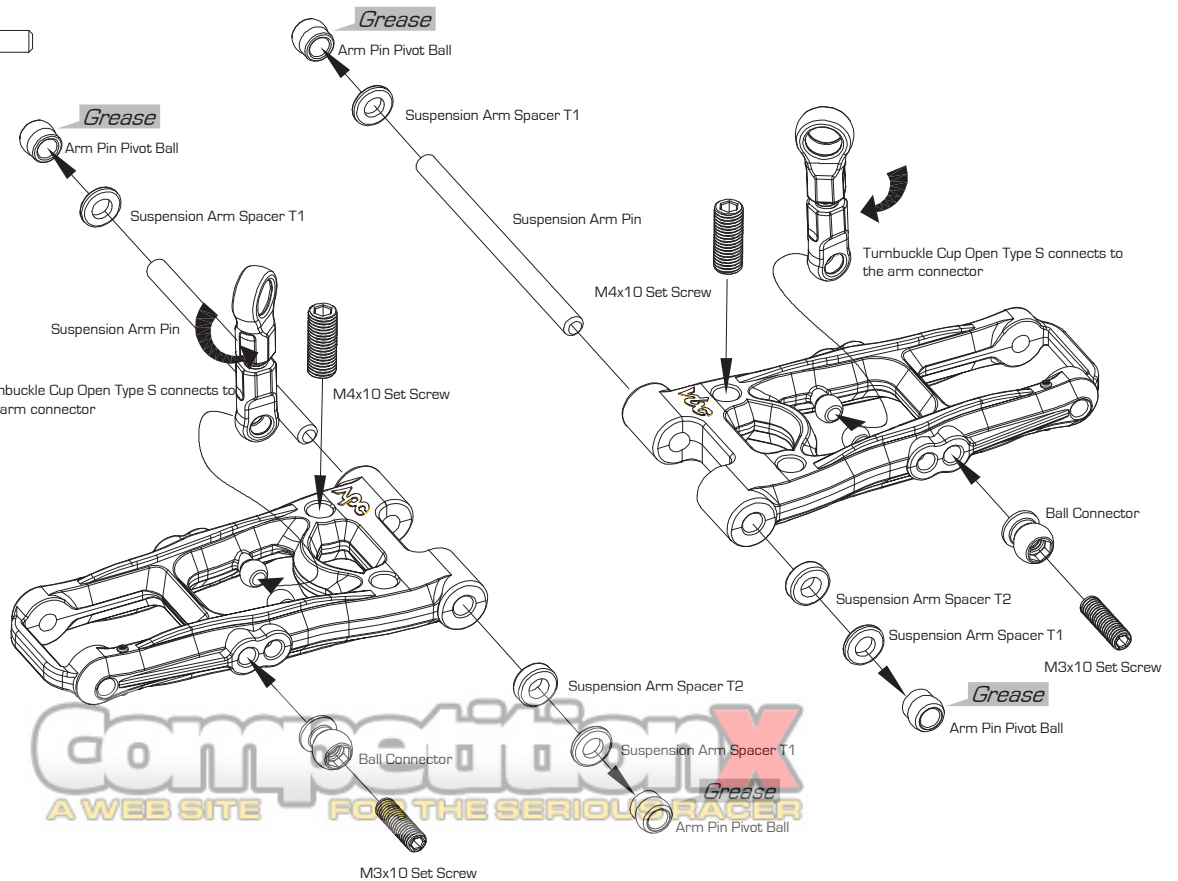
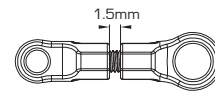

22

Front Suspension Assembly Part 2

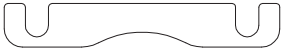

1mm Suspension Shim A-01-VBC-0037 x 1



F00 Suspension Mount B-02-VBC-0060-00 x 1



M3x6 Flat Head Screw C-02-SC-F0306 x 2

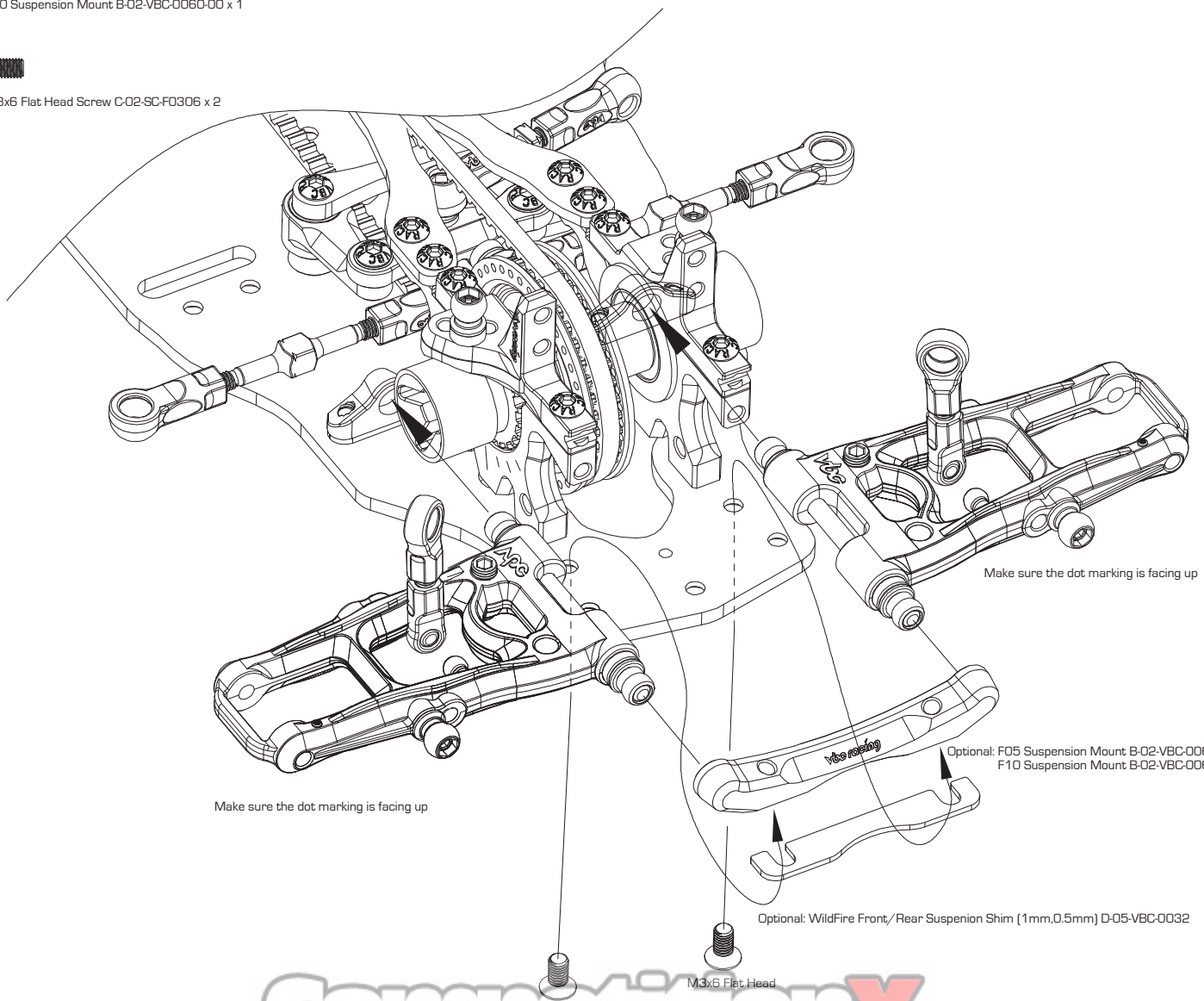

23

Front Suspension Assembly Part 3

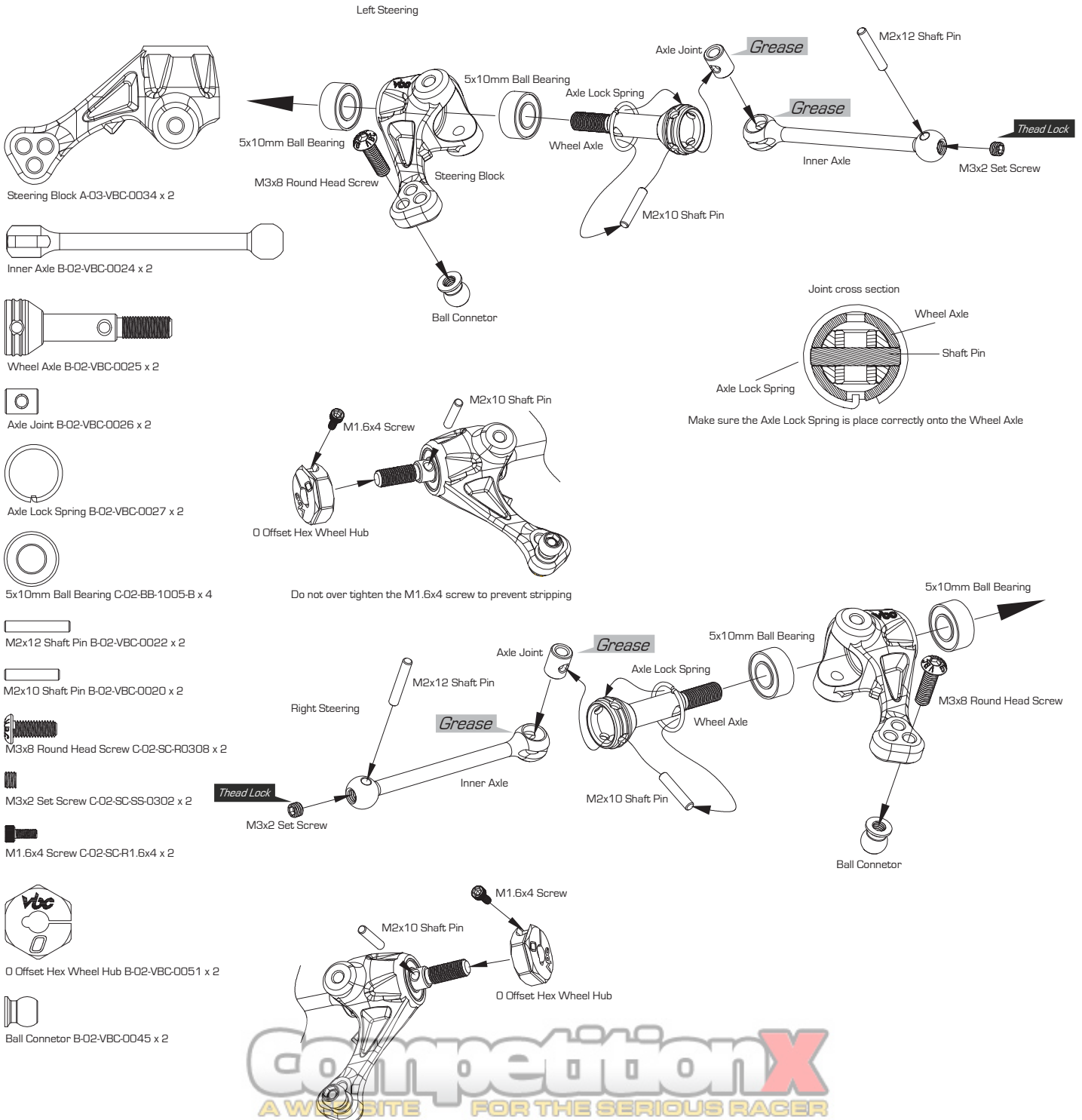

24

Front Suspension Assembly Part 4

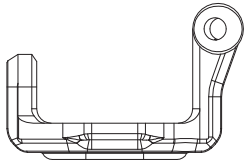

Right C-Hub A-03-VBC-0031 x 1

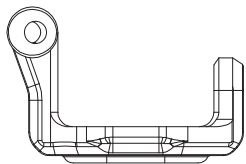

Left C-Hub A-03-VBC-0030 x 1



Turnbuckle Cup A-03-VBC-0039 x 2



Turnbuckle Cup S A-03-VBC-0056 x 2



Ball Connector B-02-VBC-0045 x 2



M3x32mm Turnbuckle B-02-VBC-0036 x 2

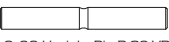

3x23 Upright Pin B-02-VBC-0032 x 2



Steering Swivel Tube B-02-VBC-0033 x 4



M3x12 Set Screw C-02-SC-SS-0312 x 2



M3x6 Set Screw C-02-SC-SS-0306 x 2



M3x9 Round Head Screw C-02-SC-R0308 x 2

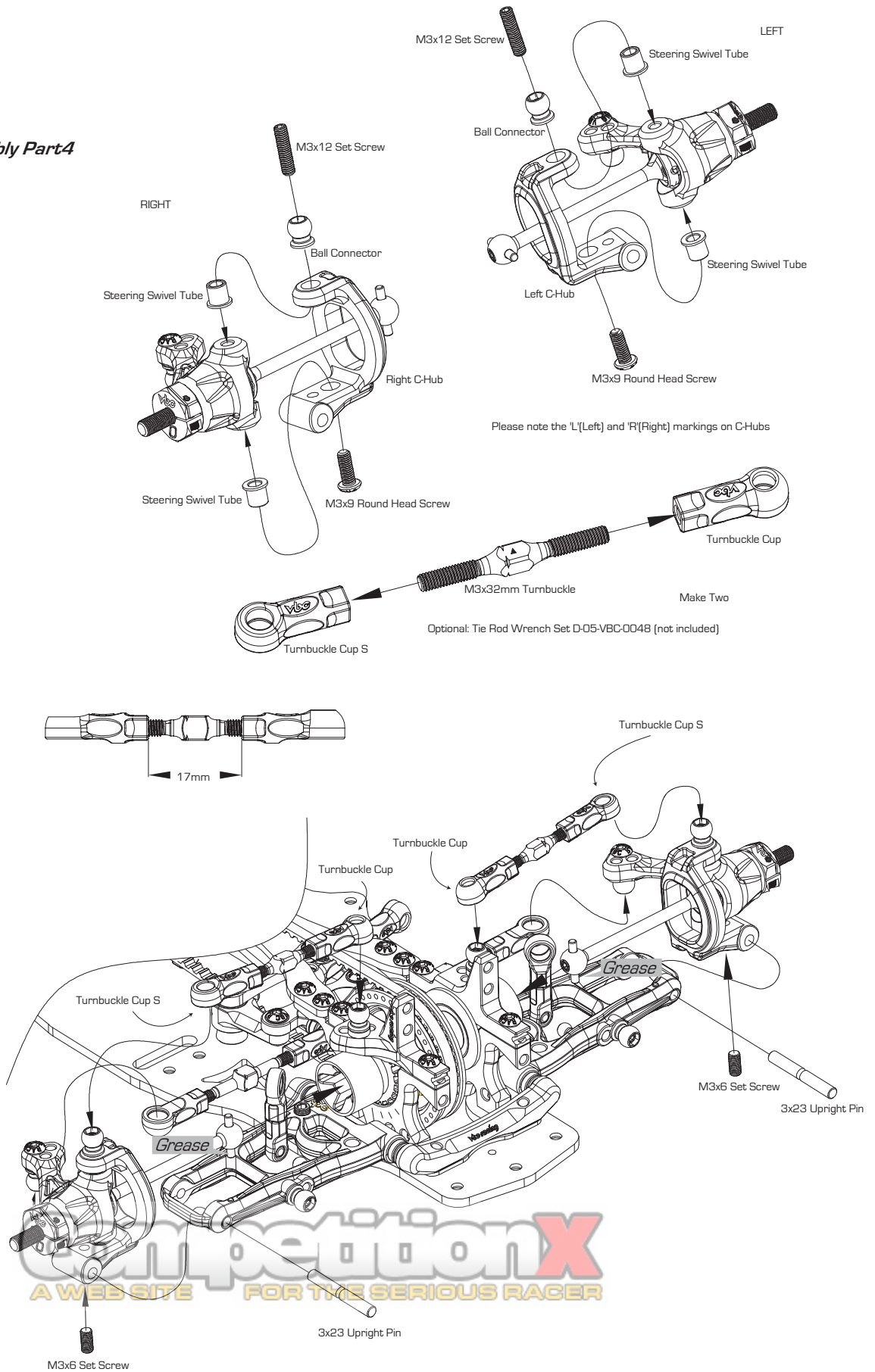

CompetitionX
A WEB SITE FOR THE SERIOUS RACER

25

Front and Rear Stabilizers

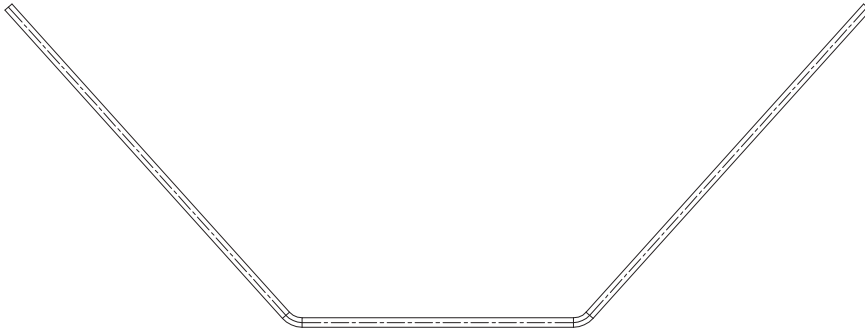

Rear Stabilizer 1.3 B-02-VBC-0075-13 x 1



Front Stabilizer 1.3 B-02-VBC-0074-13 x 1



Stabilizer Connector B-02-VBC-0047 x 4



M3x3mm Set Screw C-02-SC-SS-0303 x 6



Stabilizer Collar B-02-VBC-0070 x 2

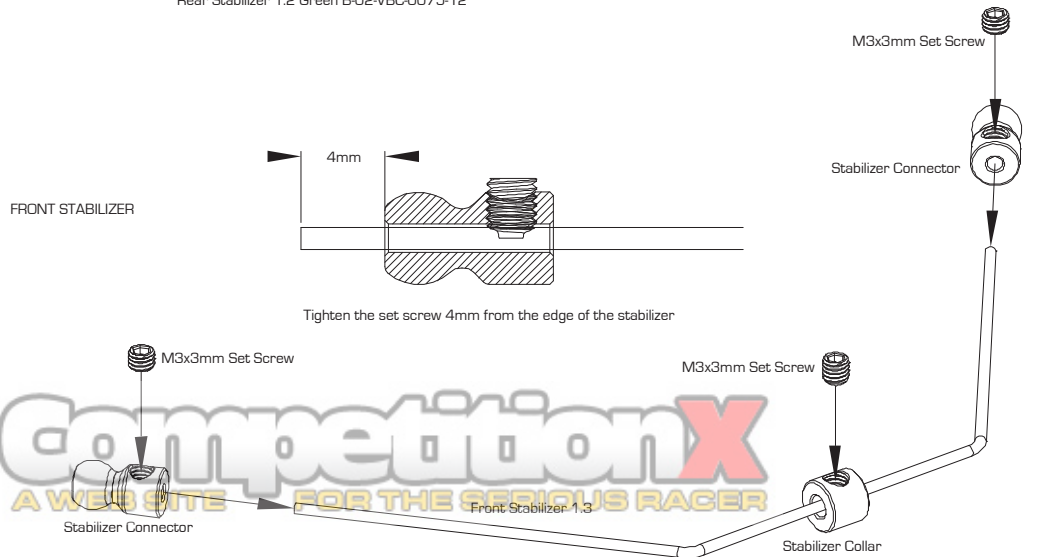
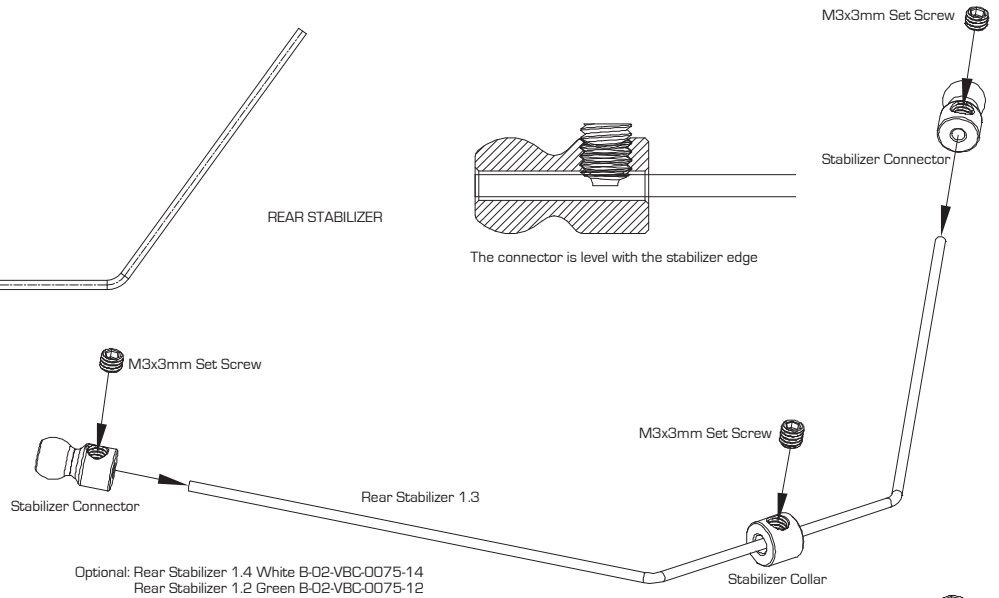

Competition X
A WEB SITE FOR THE SERIOUS RACER

26

Install Front and Rear Stabilizers

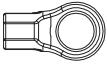

Turnbuckle Cup Open Type L A-03-VBC-0041 x 4

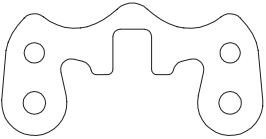

Graphite Stabilizer Mount B-02-VBC-0071 x 2



M3x3mm Set Screw C-02-SC-SS-0303 x 4



M3x10mm Set Screw C-02-SC-SS-0310 x 2



M3x6mm Flat Head Screw C-02-SC-F0306 x 4

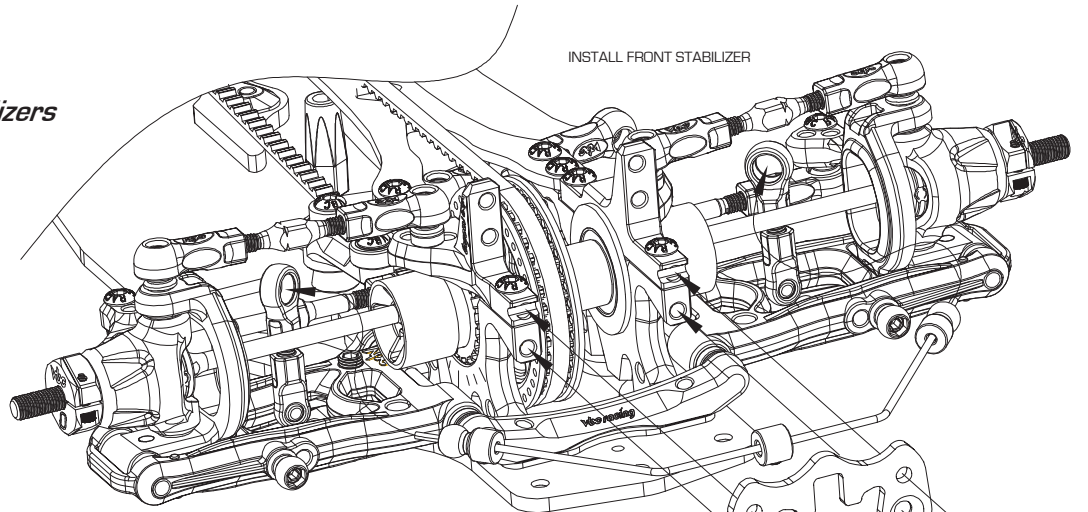

INSTALL FRONT STABILIZER

Graphite Stabilizer Mount

M3x3mm Set Screw

M3x6mm Flat Head

M3x6mm Flat Head

INSTALL FRONT STABILIZER

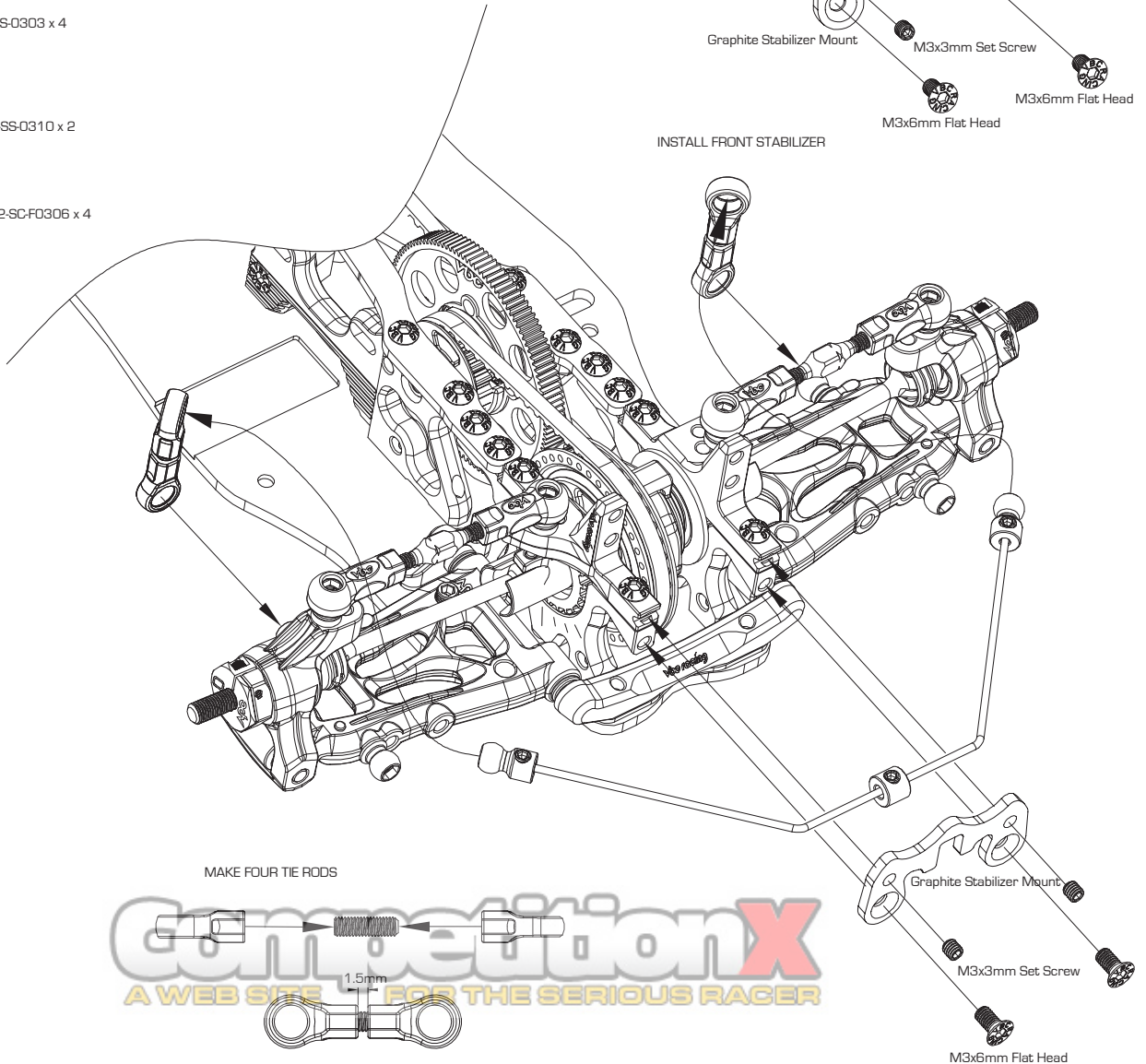

INSTALL FRONT STABILIZER

Graphite Stabilizer Mount

M3x3mm Set Screw

M3x6mm Flat Head

MAKE FOUR TIE RODS

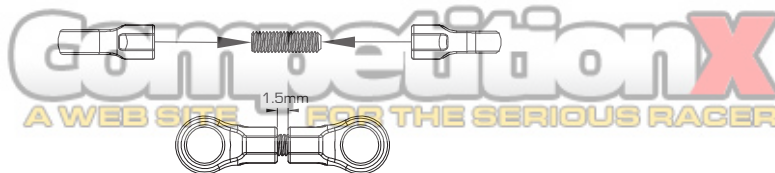

1.5mm

Note the double ring face to ball connector

27

Assemble Oil Shocks

MAKE 4 SHOCKS

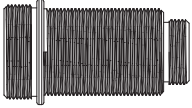

Shock Body B-02-VBC-0039 x 4

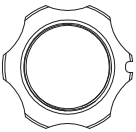

Shock Height Adjuster B-02-VBC-0042 x 4



Shock Bottom Cap B-02-VBC-0041 x 4

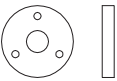

Shock Piston (3 holes) A-03-VBC-0045 x 4

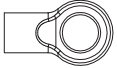

Shock Bottom Connector A-03-VBC-0066 x 4



Shaft Cap A-03-VBC-0046 x 4



Shaft Guide A-03-VBC-0058 x 4

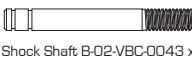

Shock Shaft B-02-VBC-0043 x 4

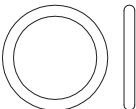

Sealer O-Ring B-03-VBC-0002 x 4



Shaft Sealer O-Ring B-03-VBC-0012 x 4



M3 E-Clip B-02-VBC-0044 x 8

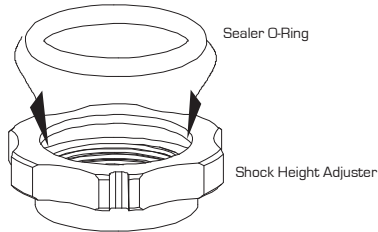

Insert Sealer O-Ring inside the Shock Height Adjuster groove

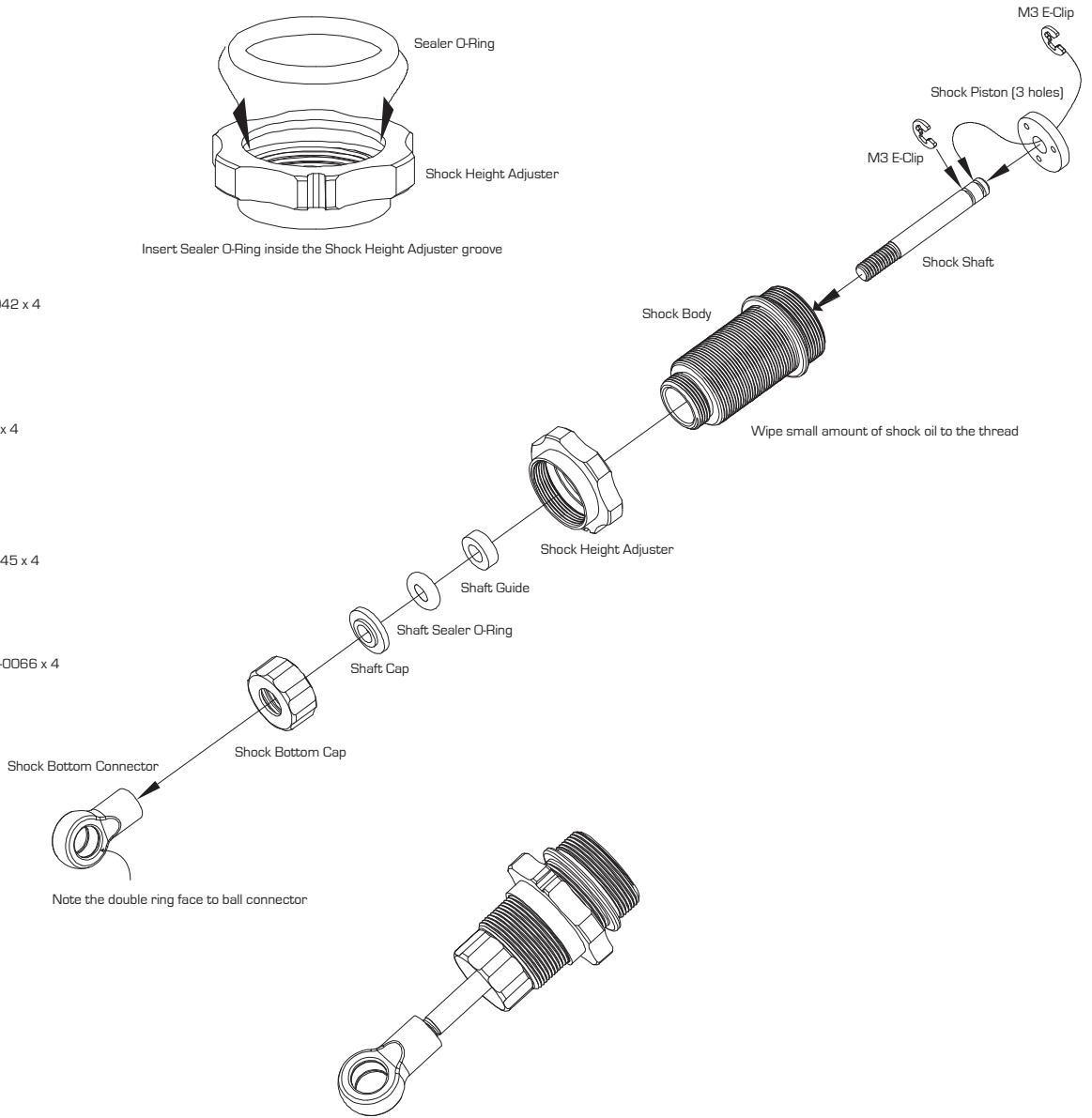

Make sure the shock shaft can move up and down freely

CompetitionX
 A WEB SITE FOR THE SERIOUS RACER

28

Assemble Oil Shocks Part 2



Shock Top Connector A-03-VBC-0042 x 4



Spring Bottom Support A-03-VBC-0043 x 4



Oil Sealer Cap B-03-VBC-0011 x 4



Shock Body Cap B-02-VBC-0040 x 4

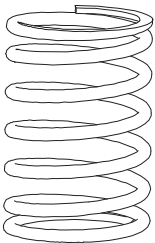

Shock Spring White (For Front) x 2

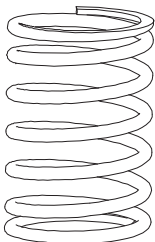

Shock Spring Red (For Rear) x 2

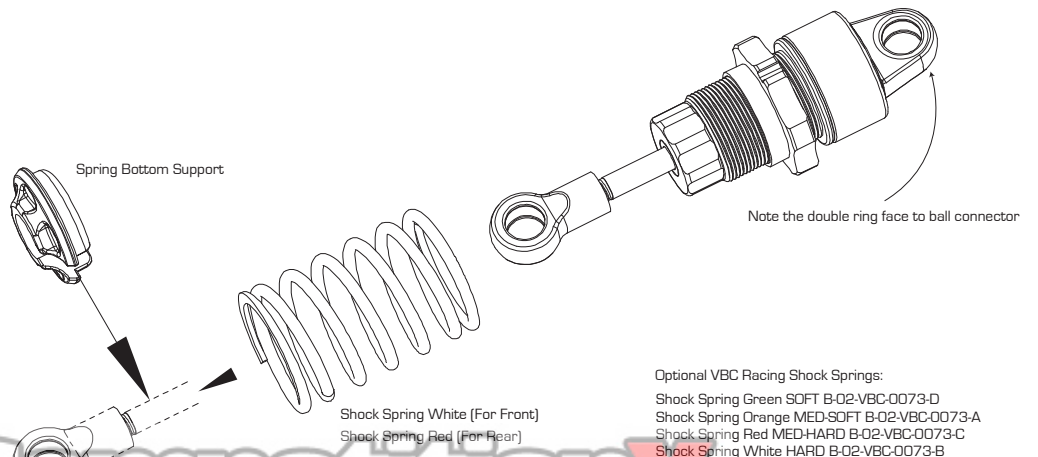
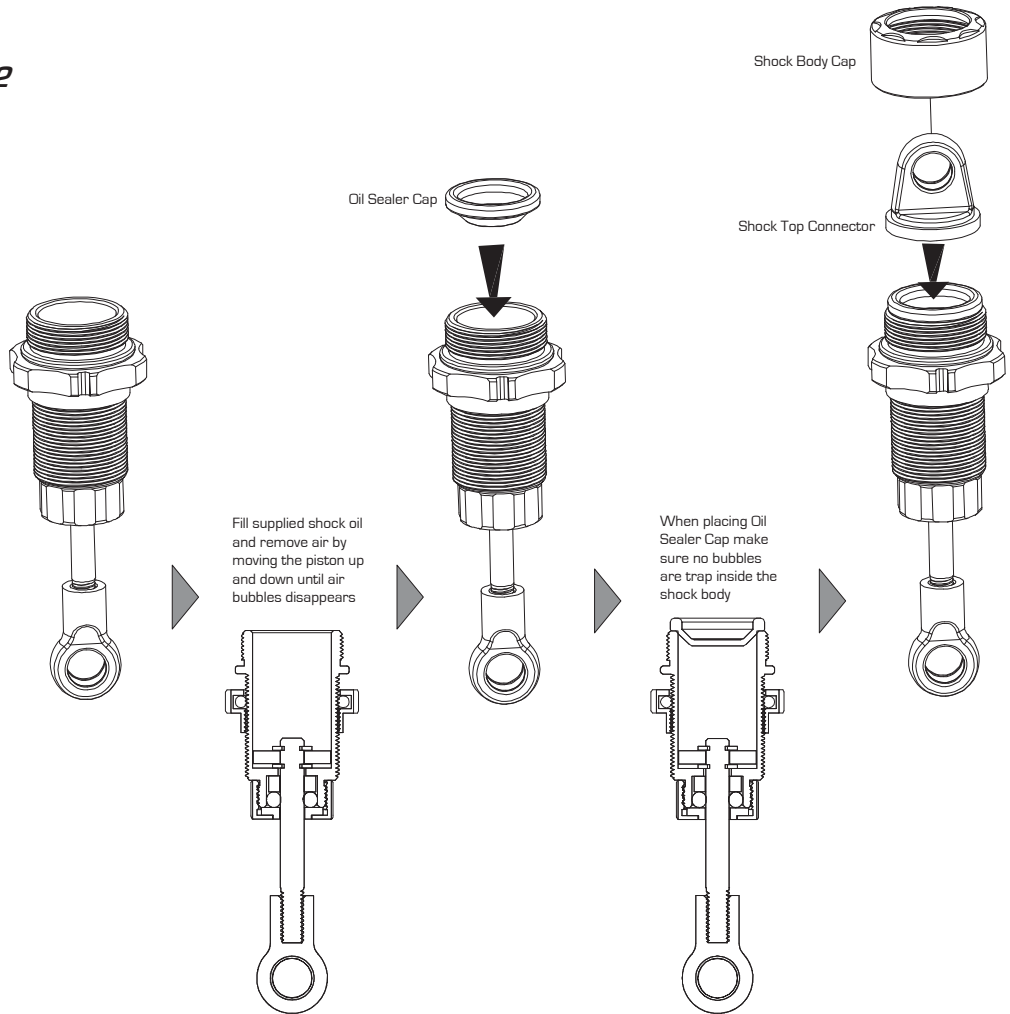

- Optional VBC Racing Shock Springs:
- Shock Spring Green SOFT B-02-VBC-0073-D
 - Shock Spring Orange MED-SOFT B-02-VBC-0073-A
 - Shock Spring Red MED-HARD B-02-VBC-0073-C
 - Shock Spring White HARD B-02-VBC-0073-B

Competition X
A WEB SITE FOR THE SERIOUS RACER

29

Install Front Shocks

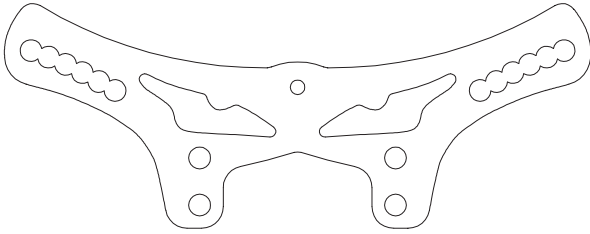

Graphite Front Shock Tower A-01-VBC-0027 x 1



Ball Connector B-02-VBC-0045 x 2



M3x6 Round Head Screw C-02-SC-SS-0306 x 6

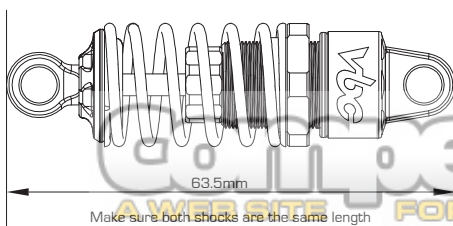
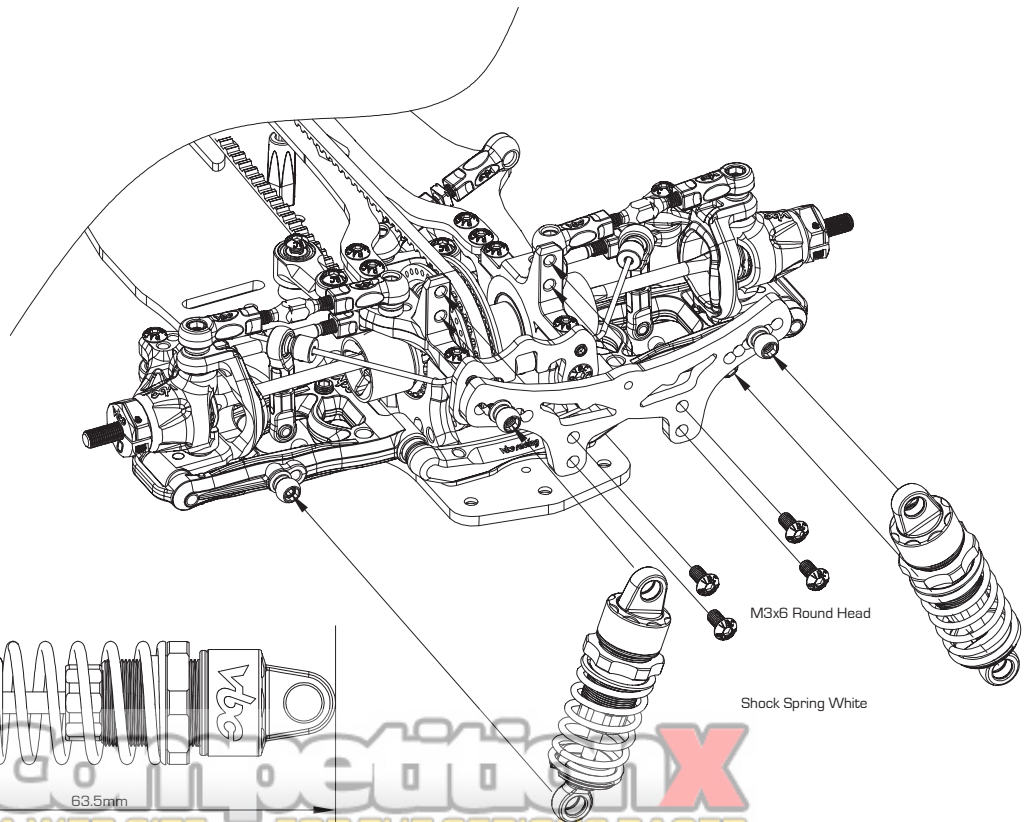
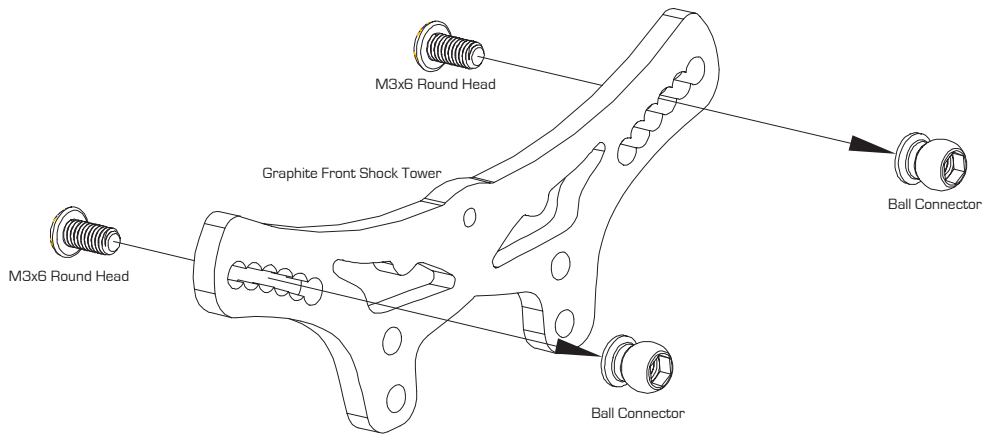

Make sure both shocks are the same length
Note the double ring face to ball connector

30

Install Rear Shocks

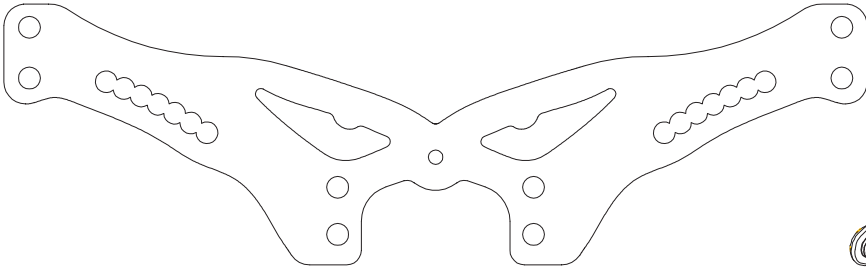

Graphite Rear Shock Tower A-01-VBC-0028 x 1



M3x6 Round Head



Ball Connector B-02-VBC-0045 x 2



M3x6 Round Head

Graphite Rear Shock Tower



M3x6 Round Head Screw C-02-SC-R0306 x 6



Ball Connector



Ball Connector

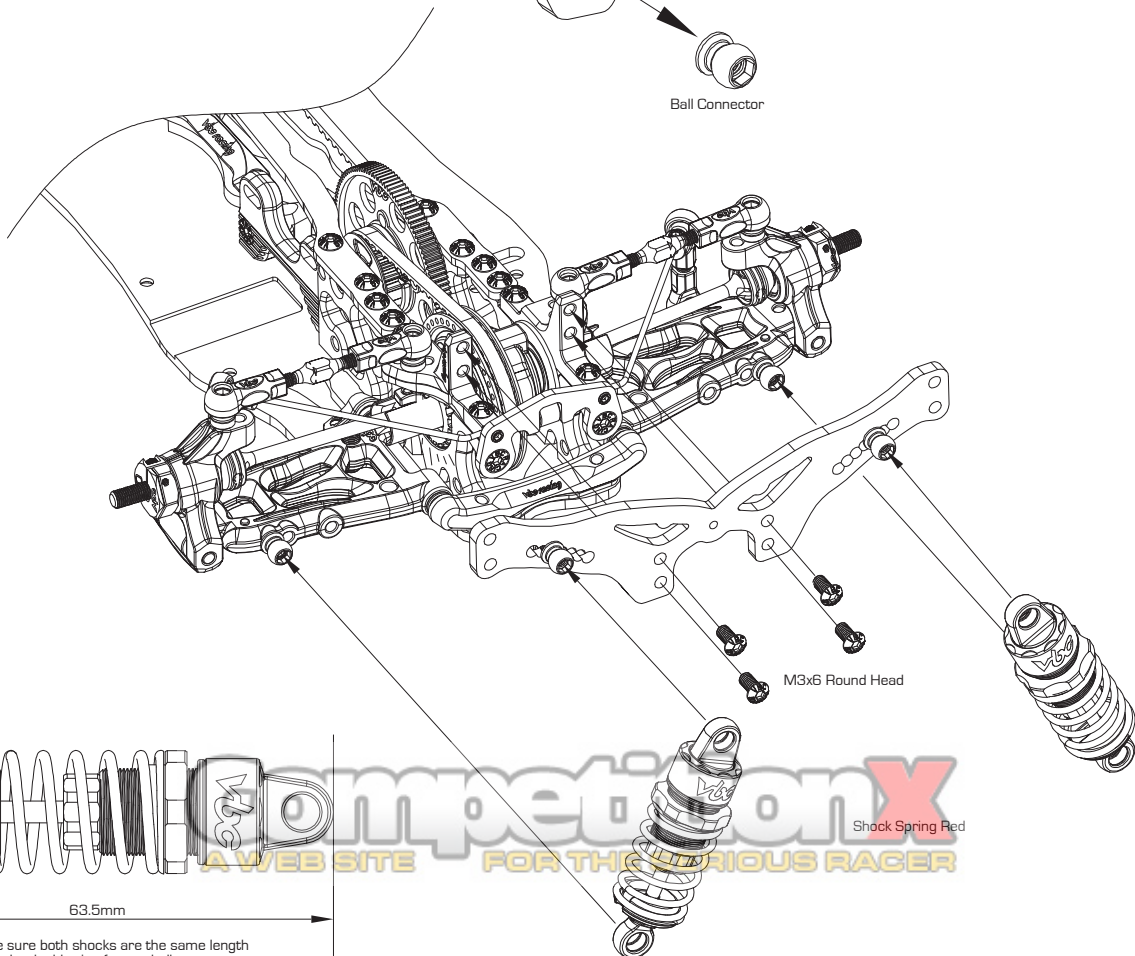

M3x6 Round Head

Shock Spring Red

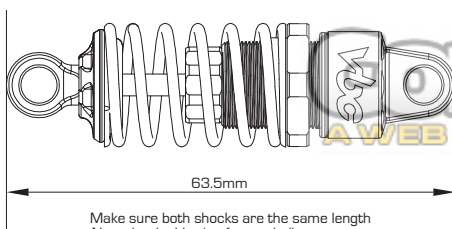

Make sure both shocks are the same length
Note the double ring face to ball connector

31

Install Motor



M3x8 Round Head Screw C-02-SC-R0308 x 2

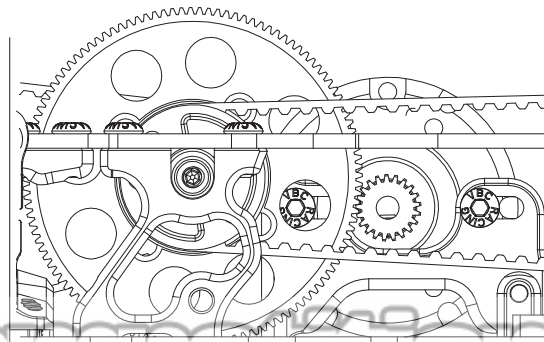
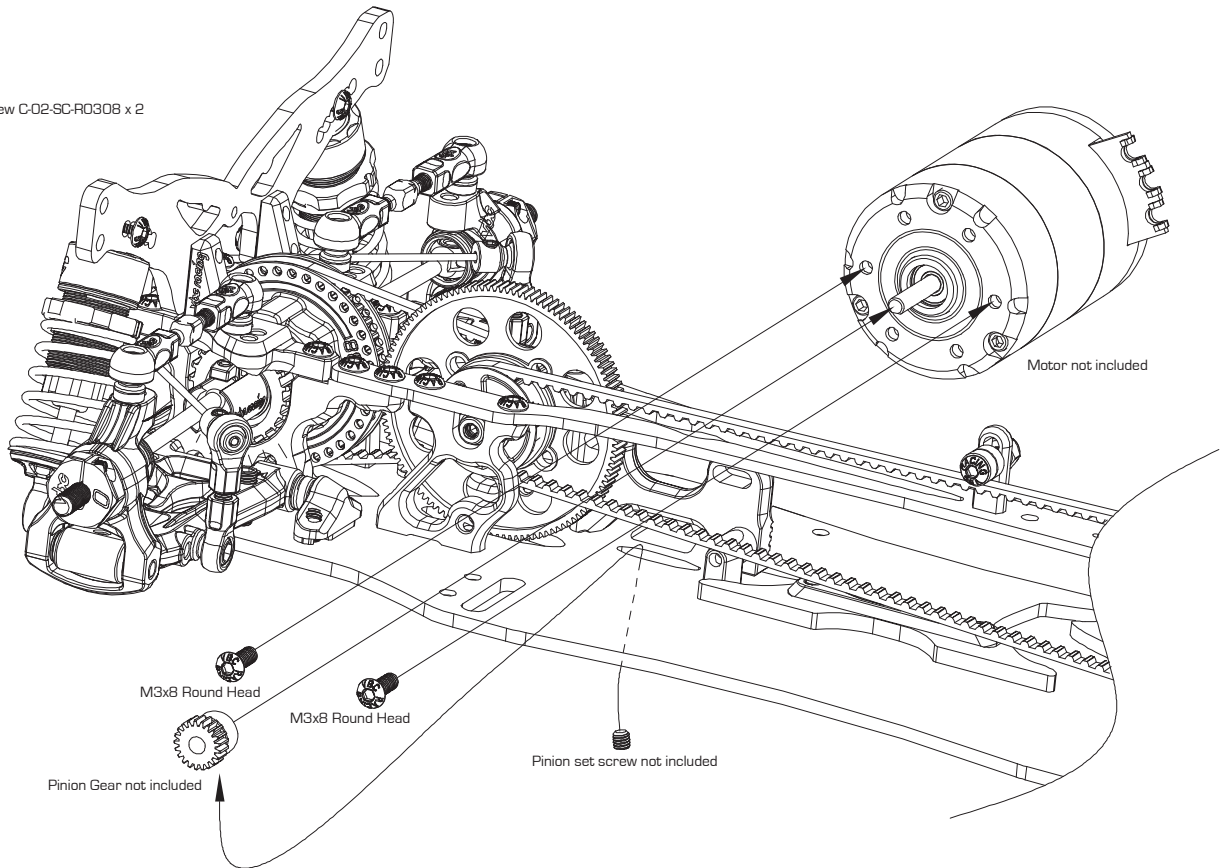

Please make sure there is enough clearance for the gears to run smoothly

COMPETITION X
A WEB SITE FOR THE SERIOUS RACER

32

Install Steering Servo

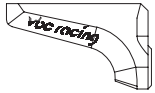

Servo Mount A B-02-VBC-0065 x 1

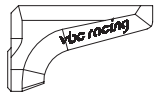

Servo Mount B B-02-VBC-0091 x 1



Servo Spacer 2mm A-03-VBC-0033 x 2
Optional Servo Spacer 1mm A-03-VBC-0032 x 2 included

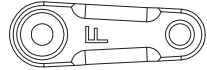

Servo Horn Type F A-03-VBC-0053 x 1

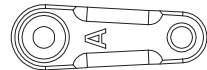

Servo Horn Type A A-03-VBC-0054 x 1



M3x8mm Round Head Screw C-02-SC-R0308 x 6



M3x6 Flathead C-02-SC-F0306 x 2



Ball Connector B-02-VBC-0045 x 1



Servo Washer [not included] x 4

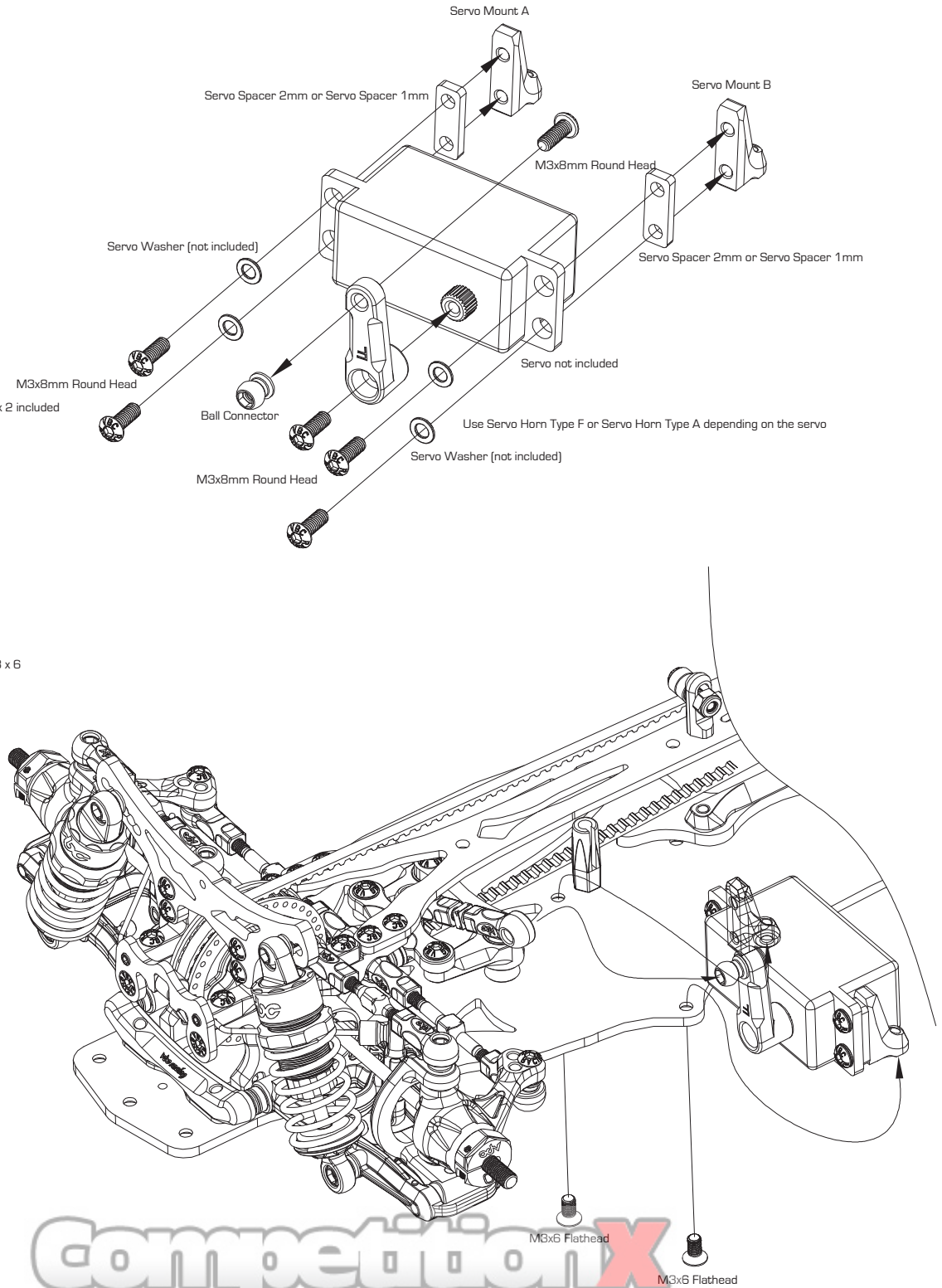

Competition X
A WEB SITE FOR THE SERIOUS RACER

33

Install Front Bumper and Body Posts



5mm Flanged Wheel Nut B-02-VBC-0086 x 4



M3x10mm Flat Head Screw C-02-SC-F0310 x 2



M3x8mm Flat Head Screw C-02-SC-F0308 x 3



5mm Flanged Wheel Nut



M3 Lock Nut C-02-SC-NN03 x 1

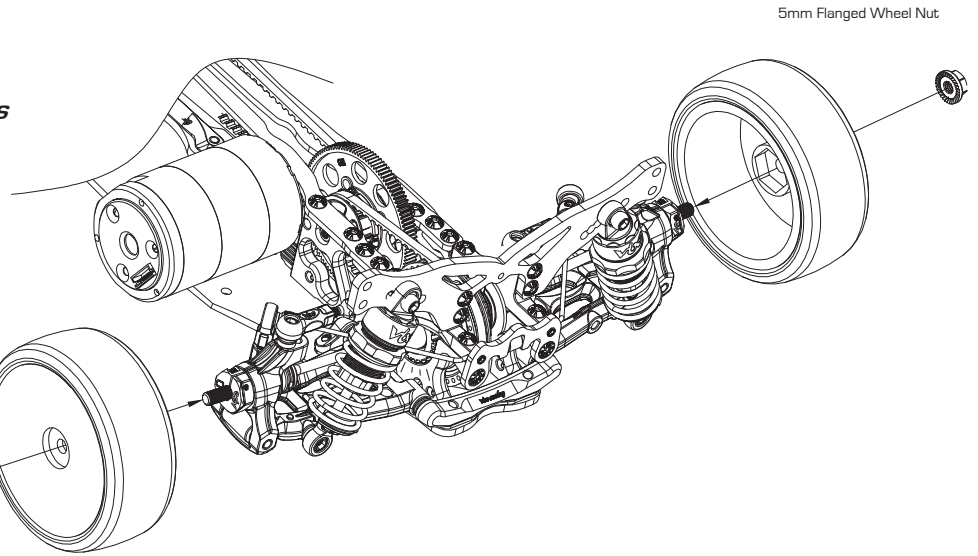

WHEELS AND TIRES NOT INCLUDED

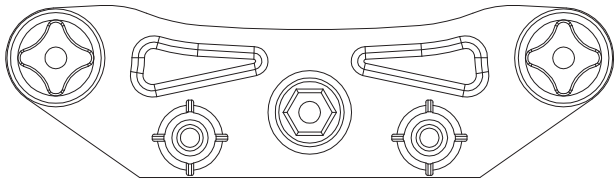

Front Bumper Bottom Support A-03-VBC-0011 x 1

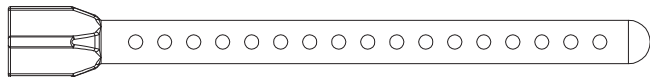

Front Body Post A-03-VBC-0013 x 2

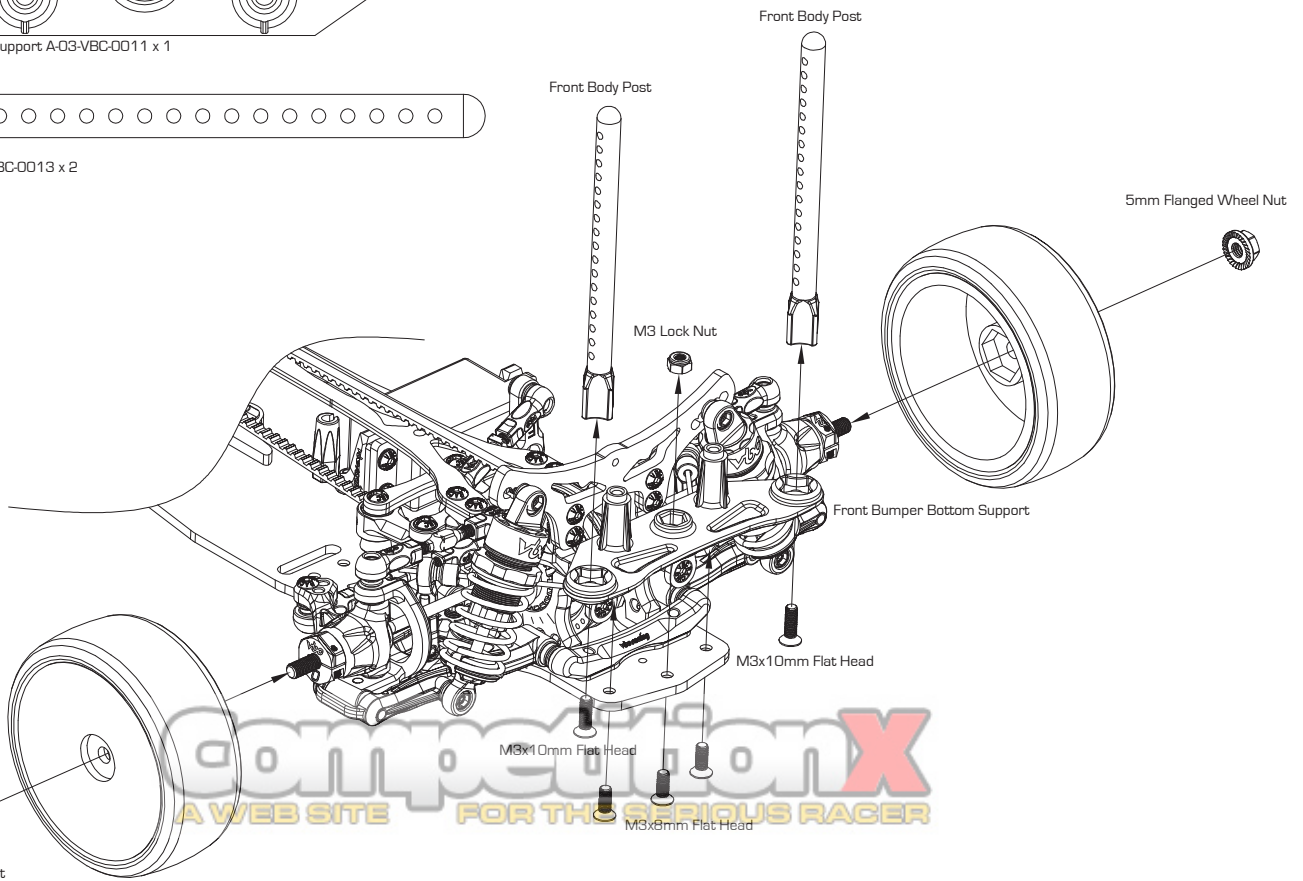

WHEELS AND TIRES NOT INCLUDED

competitionX
A WEB SITE FOR THE SERIOUS RACER

34

Install Front Bumper Part 2

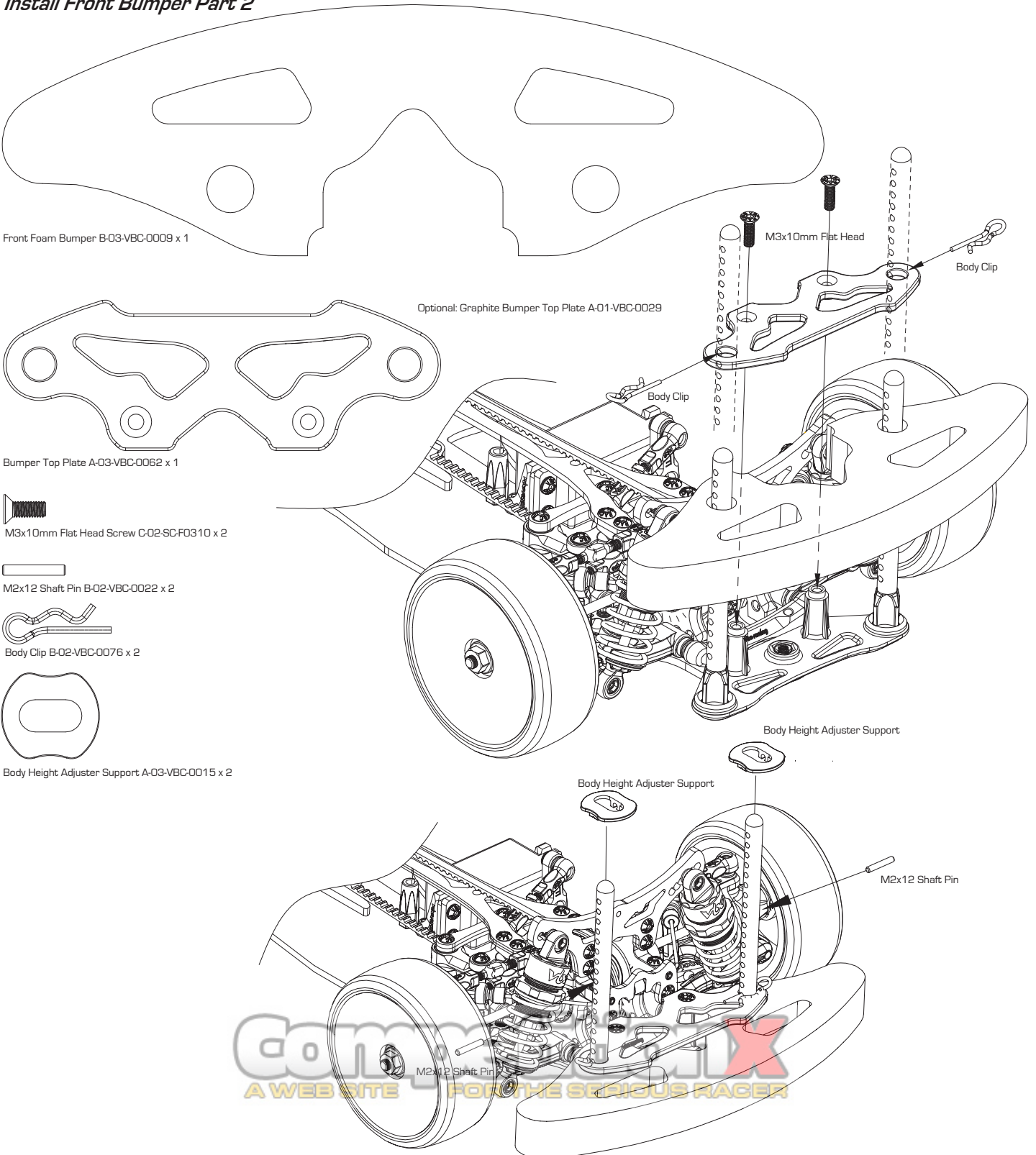

COMPONENTS
A WEB SITE FOR THE SERIOUS RACER

35

Install Rear Body Posts and Electronics

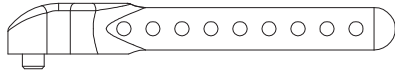

Rear Body Post A-03-VBC-0014 x 2



M3x8mm Round Head Screw C-02-SC-R0308 x 2

M2x12 Shaft Pin



M2x12 Shaft Pin B-02-VBC-0022 x 2

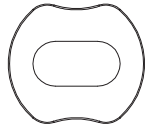

Body Height Adjuster Support A-03-VBC-0015 x 2

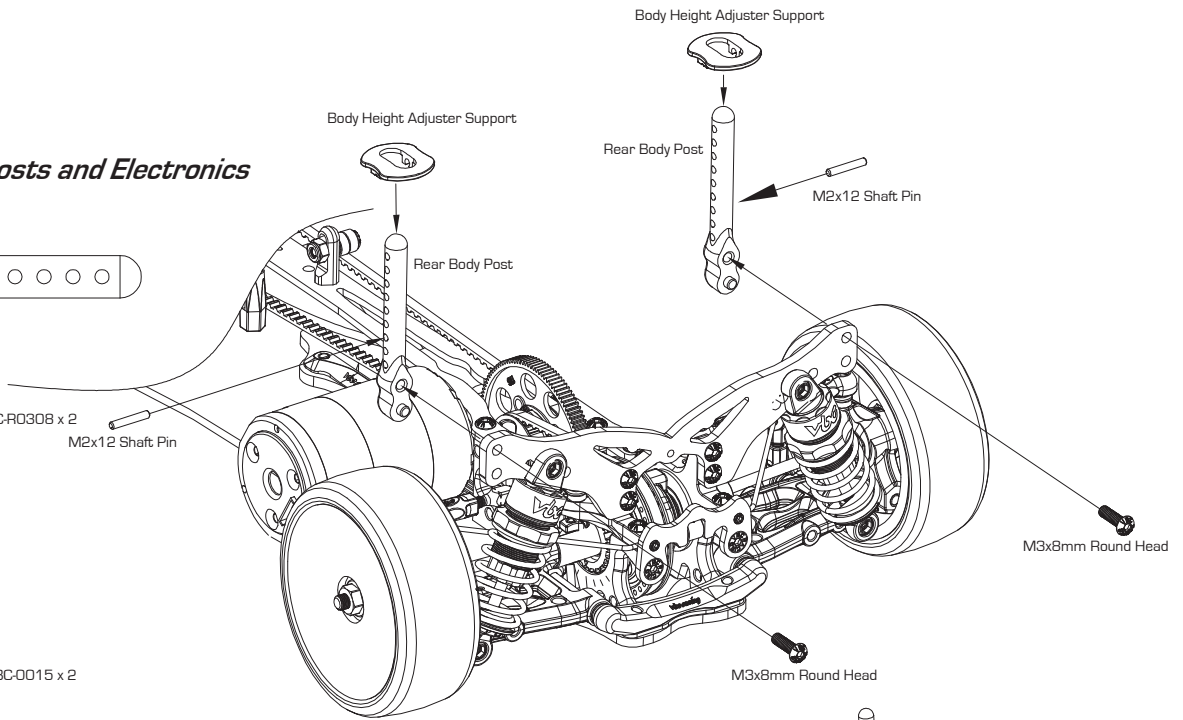

INSTALL ESC, RECEIVER AND ANTENNA TUBE
(these items are not included in this kit)

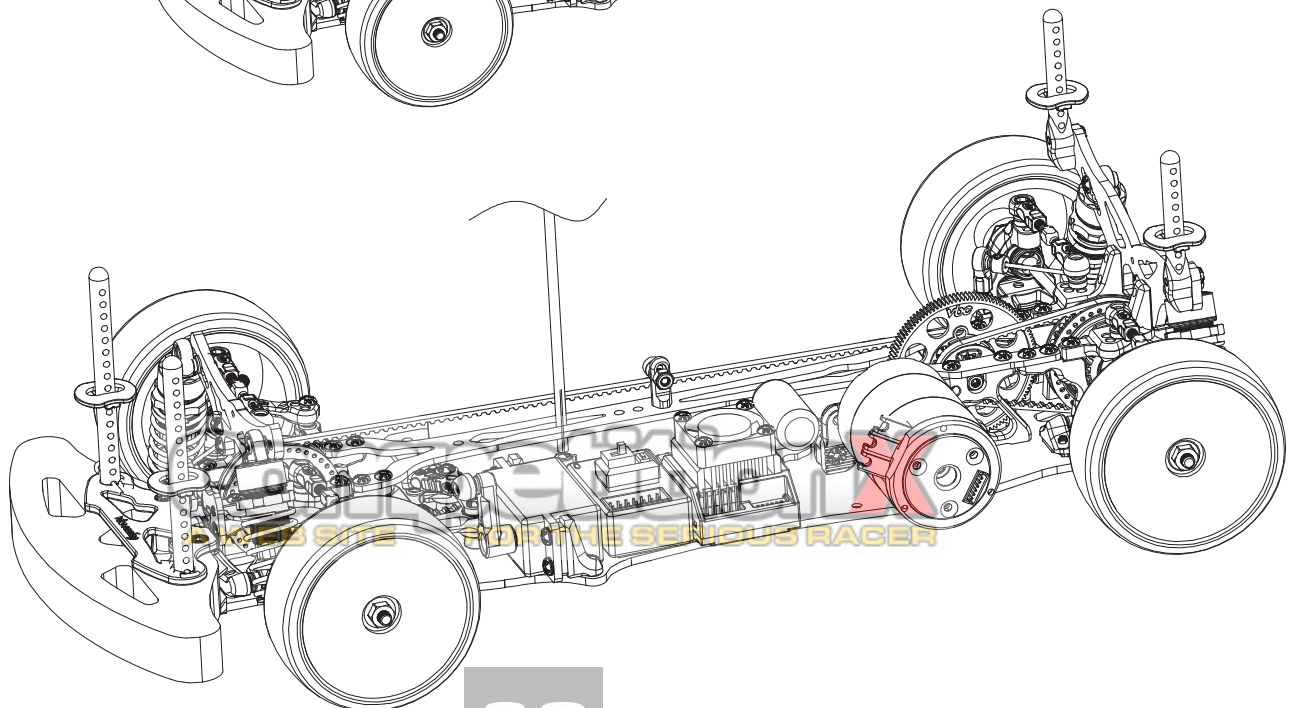
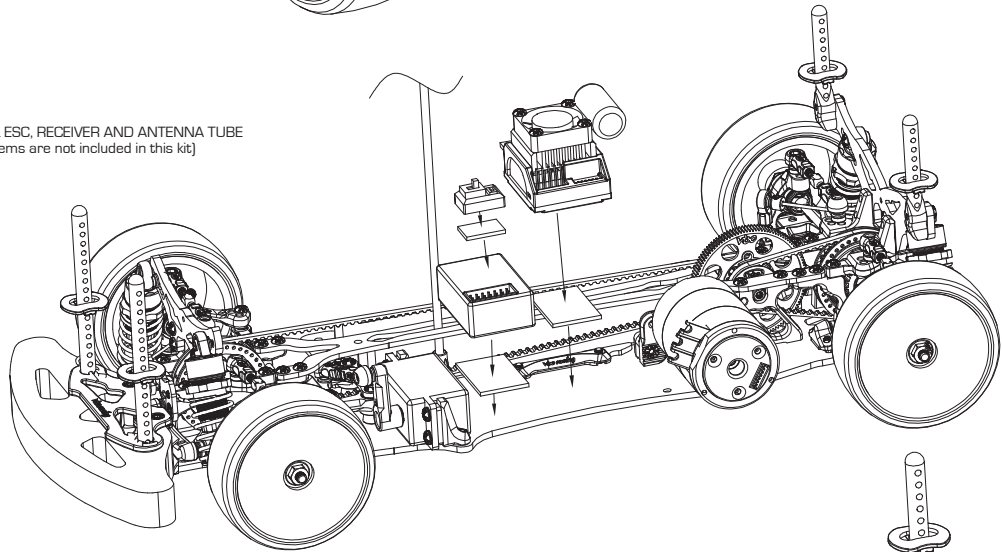

35

Continue
Install Battery Guards

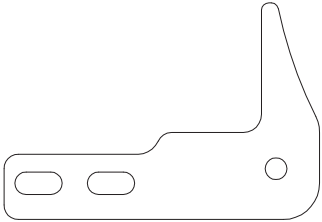

Graphite Adjustable Battery Guard A-01-VBC-0031 x 2

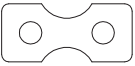

Graphite Battery Guard Spacer A-01-VBC-0032 x 2



M3x12mm Flat Head Screw x 4
C-02-SC-F0312



M3 Lock Nut C-02-SC-NN03 x 4

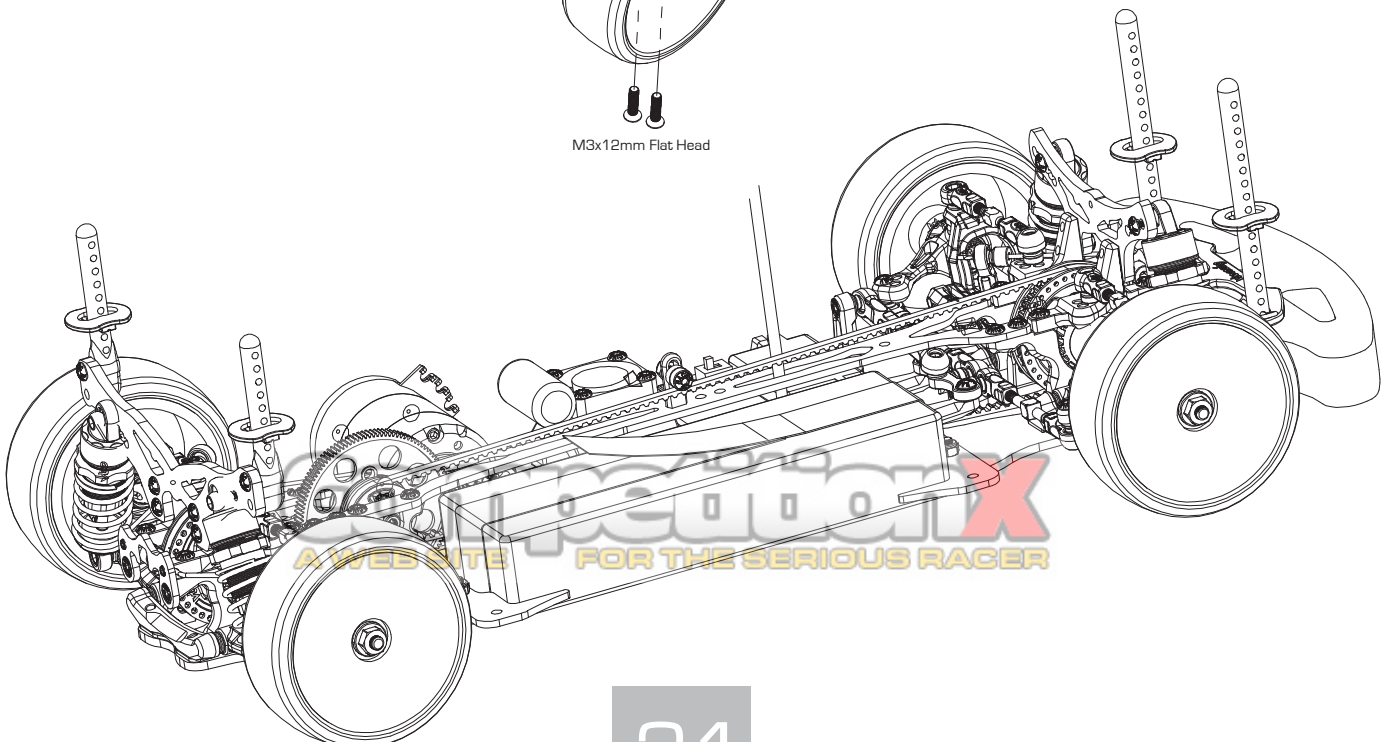
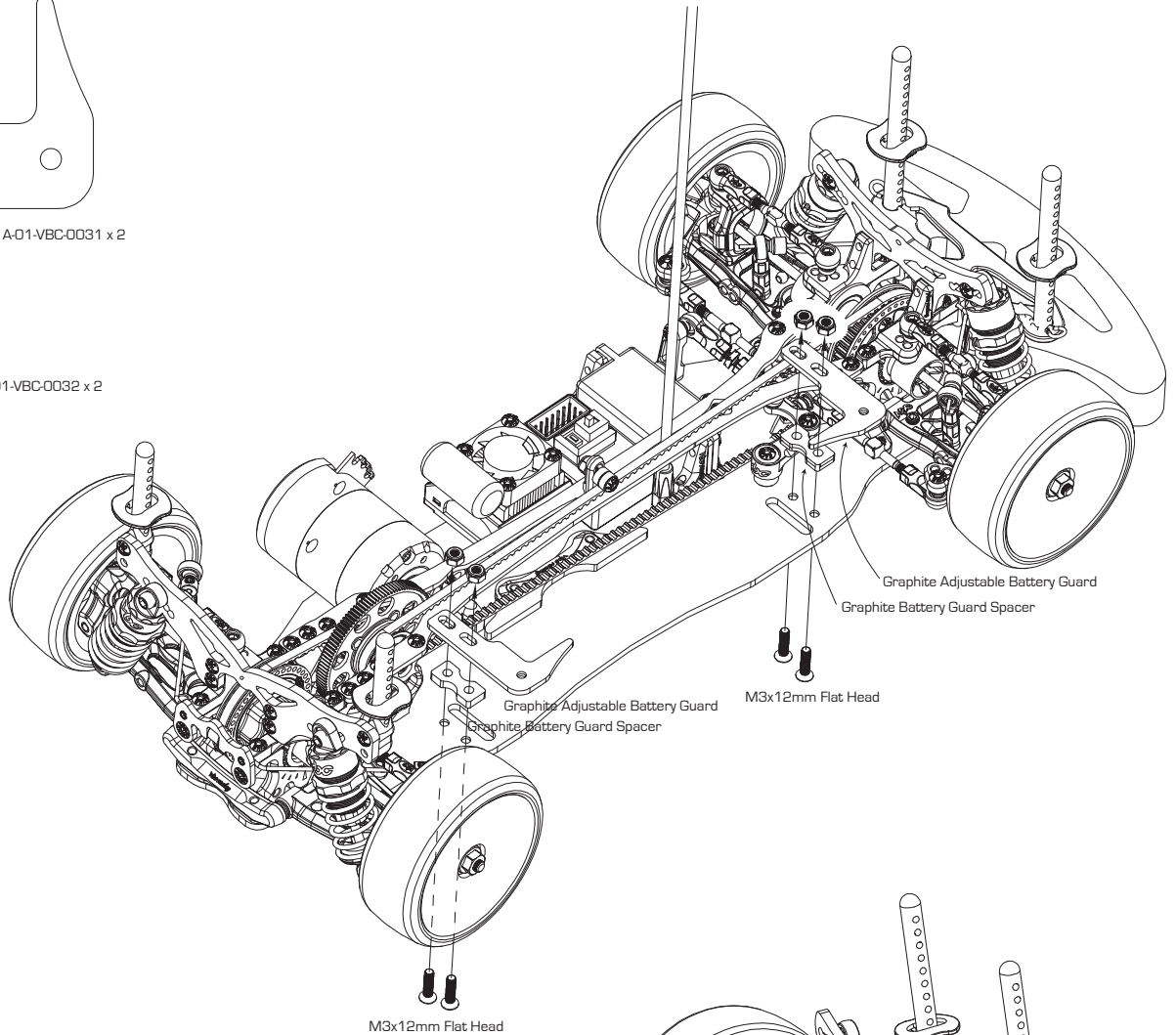

PARTS LIST



FOR ONLINE ORDERS, PLEASE VISIT OUR WEBSITE WWW.VBCRACING.COM OR VISIT YOUR NEAREST HOBBY STORE. PLEASE VISIT OUR WEBSITE FOR THE LATEST VBC WILDFIRE OPTION PARTS.

Order Number	Package Descriptions	Parts Number	Parts Descriptions	Order Number	Package Descriptions	Parts Number	Parts Descriptions
D-05-VBC-0014	WildFire Gear Differential 38T	A-03-VBC-0016	Gear Diff Housing	D-05-VBC-0042	WildFire Drive Axle Set for Front/F	B-02-VBC-0024	Inner Axle
		A-03-VBC-0017	Gear Diff Pulley 38T			B-02-VBC-0025	Wheel Axle
		A-03-VBC-0018	Diff Gear 10T			B-02-VBC-0026	Axle Joint
		A-03-VBC-0019	Diff Gear 18T			B-02-VBC-0027	Axle Lock Spring
		A-03-VBC-0020	Diff Gear Shaft			B-02-VBC-0020	M2x10 Shaft Pin
		B-03-VBC-0004	Seal Gasket			B-02-VBC-0020-12	M2x12 Shaft Pin
		B-03-VBC-0006	Diff Shaft Sealer O-Ring			C-02-SC-SS-0302	M3x2 Set Screw
		B-03-VBC-0005	Diff Housing Sealer O-Ring			C-02-BB-1005-B	5x10 Ball Bearing
		C-02-SC-F2.6x10	M2 6x10 Flathead Screw			D-05-VBC-0043	Inner Axle/Axle Joint Set
		B-02-VBC-0022	Diff Cup			B-02-VBC-0024	Inner Axle
		B-02-VBC-0020	M2x10 Shaft Pin			B-02-VBC-0026	Axle Joint
		B-02-VBC-0077	15x0.3mm Shim			B-02-VBC-0025	Wheel Axle
		B-02-VBC-0078	9.5x0.2mm Shim			B-02-VBC-0027	Axle Lock Spring
		D-05-VBC-0034	Differential Gear Set			B-02-VBC-0020	M2x10 Shaft Pin
A-03-VBC-0020	Diff Gear Shaft	B-02-VBC-0020-12	M2x12 Shaft Pin				
B-02-VBC-0022	Diff Cup	B-02-VBC-0051	0 Offset Hex Wheel Hub				
B-03-VBC-0005	Diff Housing Sealer O-Ring	C-02-SC-R1.6x4	M1.6x4 Screw				
B-03-VBC-0004	Seal Gasket	B-02-VBC-0019-10	T1 7075 Spacer				
D-05-VBC-0035	Gear Differentials Shims Set	B-02-VBC-0036	M3x32mm Turnbuckle				
B-02-VBC-0020	M2x10 Shaft Pin	B-02-VBC-0032	M3x23 Upright Pin				
C-02-BB-1510-B	10x15 Ball Bearing (2pcs)	D-05-VBC-0044	Turnbuckle Cup Open Type Set				
D-05-VBC-0022	WildFire Adjuster Ring Set	B-02-VBC-0060-00	F00 Suspension Mount				
D-05-VBC-0036	WildFire Lower Bulkhead (A+B)	A-03-VBC-0034	Steering Block (Composite)				
D-05-VBC-0026	WildFire Motor Mount Set	A-03-VBC-0017	WildFire C-Hub Set (Composite)				
B-02-VBC-0059	WildFire Main Gear Bulkhead	B-02-VBC-0033	Steering Swivel Tube				
B-02-VBC-0062	Center Suspension Mount (C0)	D-05-VBC-0045	WildFire Front Stabilizer Set				
D-05-VBC-0033	WildFire Center Suspension Shim	D-05-VBC-0046	WildFire Rear Stabilizer Set				
D-05-VBC-0030	WildFire Battery Center Position	D-05-VBC-0047	Stabilizer Connector/Collar Set				
		B-02-VBC-0071	Graphite Stabilizer Mount				
		C-02-SC-SS-0303	M3x3 Set Screw				
		A-03-VBC-0066	Shock Bottom Connector				
		A-03-VBC-0042	Shock Top Connector				
		A-03-VBC-0043	Spring Bottom Support				
		A-03-VBC-0057	Shock Piston (1 hole)				
		A-03-VBC-0044	Shock Piston (2 holes)				
		A-03-VBC-0045	Shock Piston (3 holes)				
		A-03-VBC-0046	Shaft Cap				
		A-03-VBC-0058	Shaft Guide				
		B-02-VBC-0039	Shock Body				
		B-02-VBC-0042	Shock Height Adjuster				
		B-02-VBC-0041	Shock Bottom Cap				
		A-03-VBC-0057	Shock Piston (1 hole)				
		A-03-VBC-0044	Shock Piston (2 holes)				
		A-03-VBC-0045	Shock Piston (3 holes)				
		A-03-VBC-0066	Shock Bottom Connector				
		A-03-VBC-0046	Shaft Cap				
		A-03-VBC-0058	Shaft Guide				
		B-02-VBC-0043	Shock Shaft				
		B-03-VBC-0002	Sealer O-Ring (Shock)				
		B-03-VBC-0012	Shaft Sealer O-Ring				
		B-02-VBC-0044	M3 E-Clip				
		A-03-VBC-0042	Shock Top Connector				
		A-03-VBC-0043	Spring Bottom Support				
		B-03-VBC-0011	Oil Sealer Cap				
		B-02-VBC-0040	Shock Body Cap				
		B-02-VBC-0073-C	Shock Spring (Medium Soft)				
		B-02-VBC-0043	Shock Shaft				
		B-02-VBC-0073-A	Shock Spring A				
		B-02-VBC-0073-B	Shock Spring B(Optional)				
		B-02-VBC-0073-C	Shock Spring C				
		B-02-VBC-0073-D	Shock Spring D(Optional)				
		A-01-VBC-0027	WildFire Graphite Front Shock Tower				
		A-01-VBC-0028	WildFire Graphite Rear Shock Tower				
		B-02-VBC-0065	Servo Mount A				
		B-02-VBC-0091	Servo Mount B				
		A-03-VBC-0053	Servo Horn Type F (Composite)				
		A-03-VBC-0054	Servo Horn Type A (Composite)				
		A-03-VBC-0032	Servo Spacer 1mm				
		A-03-VBC-0033	Servo Spacer 2mm				
		A-03-VBC-0011	Front Bumper Bottom Support				
		A-01-VBC-0062	Bumper Top Plate				
		A-03-VBC-0013	Front Body Post				
		A-03-VBC-0014	Rear Body Post				
		A-03-VBC-0015	Body Height Adjuster Support				
		B-02-VBC-0076	Body Clip				
		B-02-VBC-0020-12	M2x12 Shaft Pin				
		B-03-VBC-0009	Front Foam Bumper				
		A-01-VBC-0031	Graphite Adjustable Battery Guard				
		A-01-VBC-0032	Graphite Battery Guard Spacer				
		C-02-SC-F0312	M3x12 Flathead Screw				
		C-02-SC-NN03	M3 Lock Nut				
		A-01-VBC-0035-25	WildFire Standard Graphite Chassis				
		C-02-SC-F0306	M3x6 Flathead Screw				
		C-02-SC-F0308	M3x8 Flathead Screw				
		C-02-SC-F0310	M3x10 Flathead Screw				
		C-02-SC-F0312	M3x12 Flathead Screw				
		C-02-SC-R0304	M3x4 Roundhead Screw				
		C-02-SC-R0306	M3x6 Roundhead Screw				
		C-02-SC-R0308	M3x8 Roundhead Screw				
		C-02-SC-R0309	M3x9 Roundhead Screw				
		C-02-SC-R0310	M3x10 Roundhead Screw				
		C-02-SC-R-0312	M3x12 Roundhead Screw				
		C-02-SC-R-0316	M3x16 Roundhead Screw				
		A-03-VBC-0021	Front Spool Pulley 38T				
		A-03-VBC-0022	Pulley Belt Guide				
		A-03-VBC-0049	Spool Drive Shaft				
		A-03-VBC-0055	Front Spool Outdrive				
		C-02-SC-R0306	M3x6 Roundhead Screw				
		C-02-SC-F0312	M3x12 Flathead Screw				
		A-03-VBC-0055	Front Spool Outdrive				
		A-03-VBC-0049	Spool Drive Shaft				
		A-03-VBC-0021	Front Spool Pulley 38T				
		A-03-VBC-0022	Pulley Belt Guide				
		A-03-VBC-0024	Front Suspension Arm (Composite)				
		A-03-VBC-0050	Rear Suspension Arm (Composite)				
		A-03-VBC-0051	Suspension Arm Spacer T1 (Composite)				
		A-03-VBC-0052	Suspension Arm Spacer T2 (Composite)				
		B-02-VBC-0029	Suspension Arm Pin				
		B-02-VBC-0035	Arm Pin Pivot Ball				
		B-02-VBC-0061-30	E30 Suspension Mount				
		A-01-VBC-0037	1mm Suspension Shim				
		A-01-VBC-0041	0.5mm Suspension Shim(Optional)				
		A-03-VBC-0037	Rear Suspension Upright (Composite)				
		A-03-VBC-0038	Shaft End Shoe				



COMPETITION GRADE HIGH PERFORMANCE RADIO CONTROL RACING CAR CHASSIS KIT



1/10 4WD ELECTRIC COMPETITION TOURING CAR KIT