



Driver: _____
 Date: _____
 Event: _____
 Class: _____

Track: _____ Length: _____
 carpet asphalt concrete
 Flat Banked True Oval Tri-Oval
 Traction: high medium low

FRONT SUSPENSION

Camber: _____ Caster: _____
 Toe IN / OUT _____

Camber Rate Shims: _____
 Axle Spacing Shims: _____

Spring: _____
 Lube: _____
 Pre-Load: _____

LEFT

RIGHT

Camber Rate Location
 Ride Height Spacers
 Trac Width Location

Camber Rate Shims: _____
 Axle Spacing Shims: _____

Spring: _____
 Lube: _____
 Pre-Load: _____

SHOCKS

Left Shock _____ Right Shock _____
 Spring _____
 Oil _____
 Angle _____

Center Shock
 Spring _____ Angle _____
 Oil _____ Length _____
 Piston _____ Droop _____

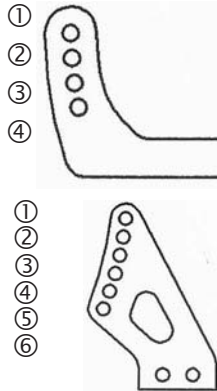

TIRES

Compound:	Front	Left	Right	Shade in Area
	Rear			Traction
				Compound:
Diameter:	Front	Left	Right	<input type="checkbox"/>
	Rear			<input type="checkbox"/>
				LF RF
Width:	Front	Left	Right	<input type="checkbox"/>
	Rear			<input type="checkbox"/>
				LR RR

Tire Traction Type: _____

MAIN CHASSIS - MARK AREAS OF BATTERIES, RADIO GEAR, AND WEIGHTS

Chassis Height by Location

① _____
 ② _____
 ③ _____
 ④ _____
 ⑤ _____

Measured From:
 Top of Chassis
 Bottom of Chassis

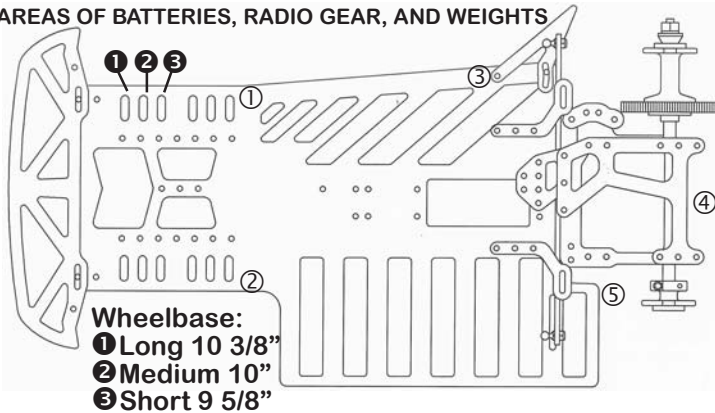

Rear Steer: 0° 1/2°
 Diff Hub: Wide Standard
 Axle Shims: _____
 Pod Length: Long Standard
 Pod: Off-set Center
 Axle Shims: _____
 T-plate: Off-set Center
 T-plate Type: F-Glass Steel
 T-plate Cut: _____

MISC...

Car Body: _____
 Wing On Body On Pod
 Wing Type: _____
 Distance from Body Posts to Leading Edge of Wing: _____
 Wing Angle: _____
 Spoiler Height: _____

Motor: _____
 Turns: _____ Winds: _____
 Pinion: _____ Spur: _____
 Roll Out: _____
 Battery: _____
 4 Cell 6 Cell
 Tire LF: _____ RF: _____
 Weights LR: _____ RR: _____
 Overall Weight: _____

Driver Comments / Key Areas of Track: _____

