



**CIRCUITO \ CIRCUIT:** .....

**DATA \ DATE:** .....

**CONDIZIONI PISTA \ TRACK CONDITION:** .....

**TEMPERATURA \ TEMPERATURE:** .....

**AUTOMODELLO \ CAR :** .....

**CARROZZERIA \ BODYSHELL:** .....

**GOMME \ TYRES:** .....

**MOTORE \ MOTOR:** .....

**SERVOCOMANDI \ SERVOS:** .....

**RADIO \ TRANSMITTER:** .....

**CARBURANTE \ FUEL MIX:** .....





**1) BASE CHASSIS STATIC POSITION**

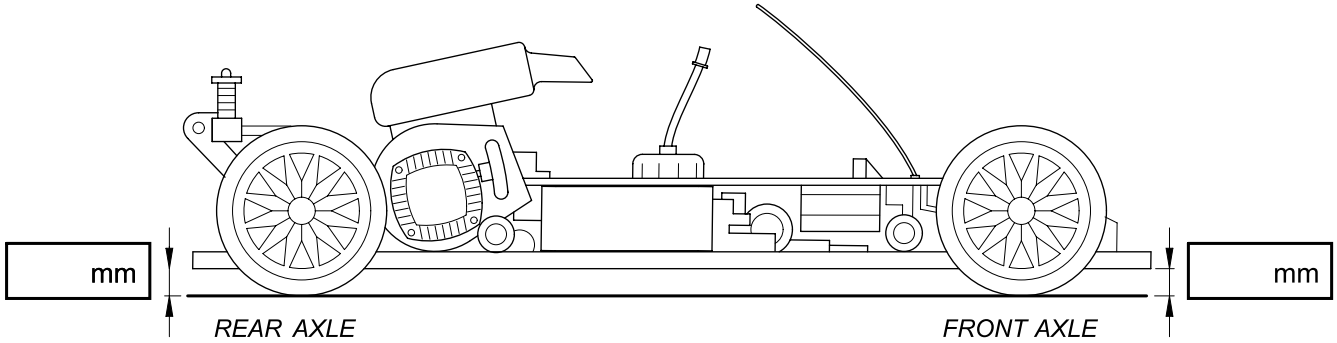

**2) FRONT CAMBER STATIC POSITION**

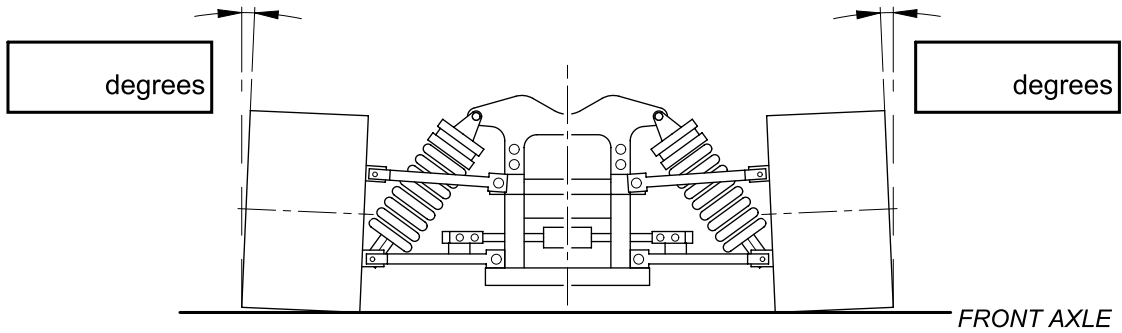

**3) DINAMIC REAR CAMBER**

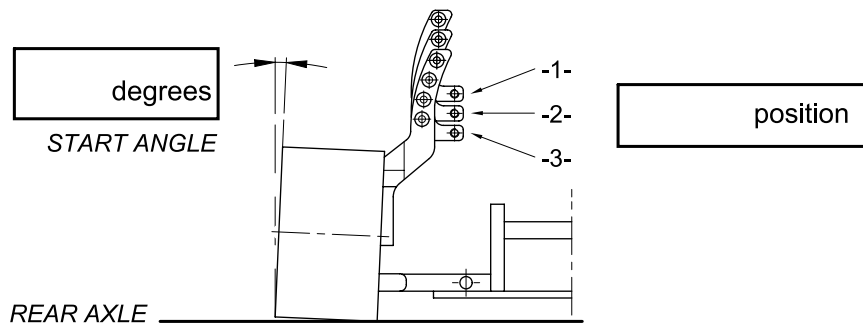

**4) HAKERMAN ANGLE**

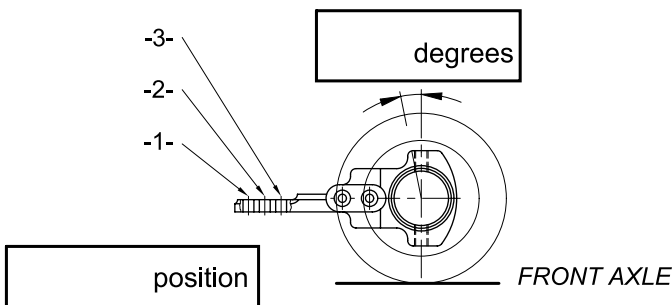

**5) SERVO SAVER**

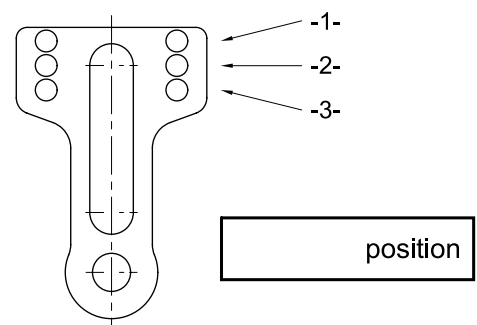



6) REAR ROLL-BAR

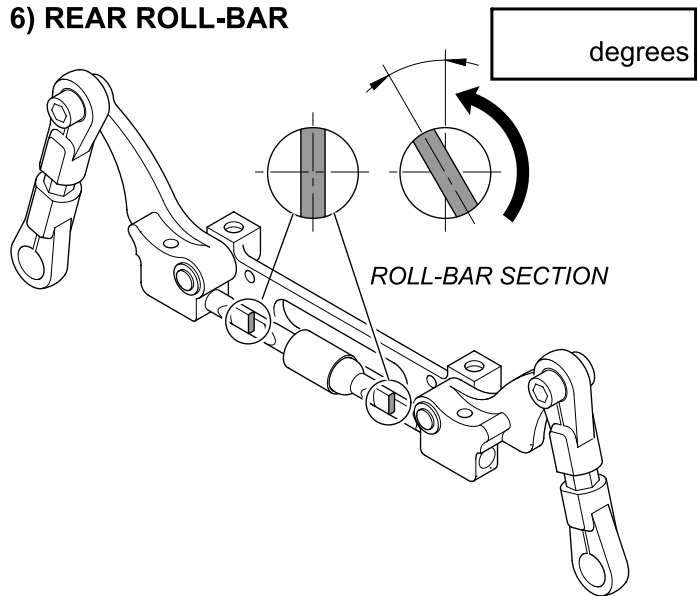

7) FRONT ROLL-BAR

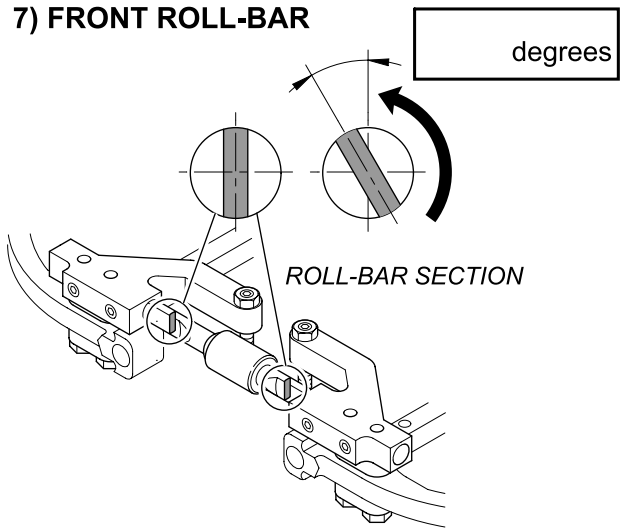

8) REAR SHOCK ABSORBER

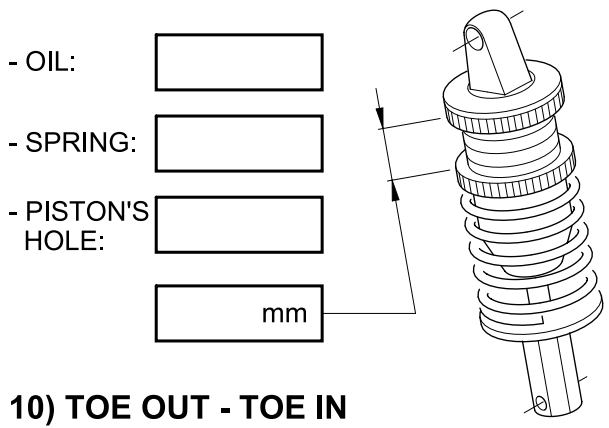

9) FRONT SHOCK ABSORBER

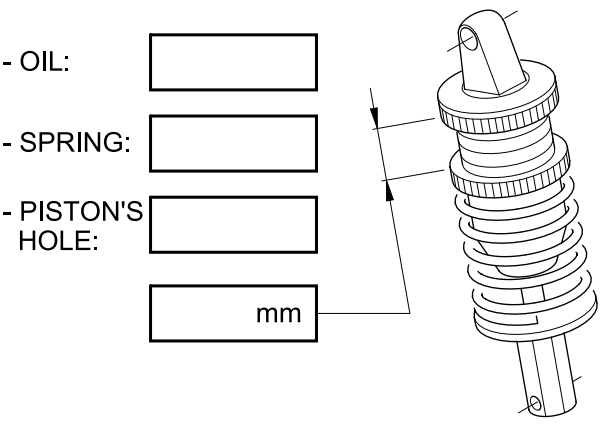

10) TOE OUT - TOE IN

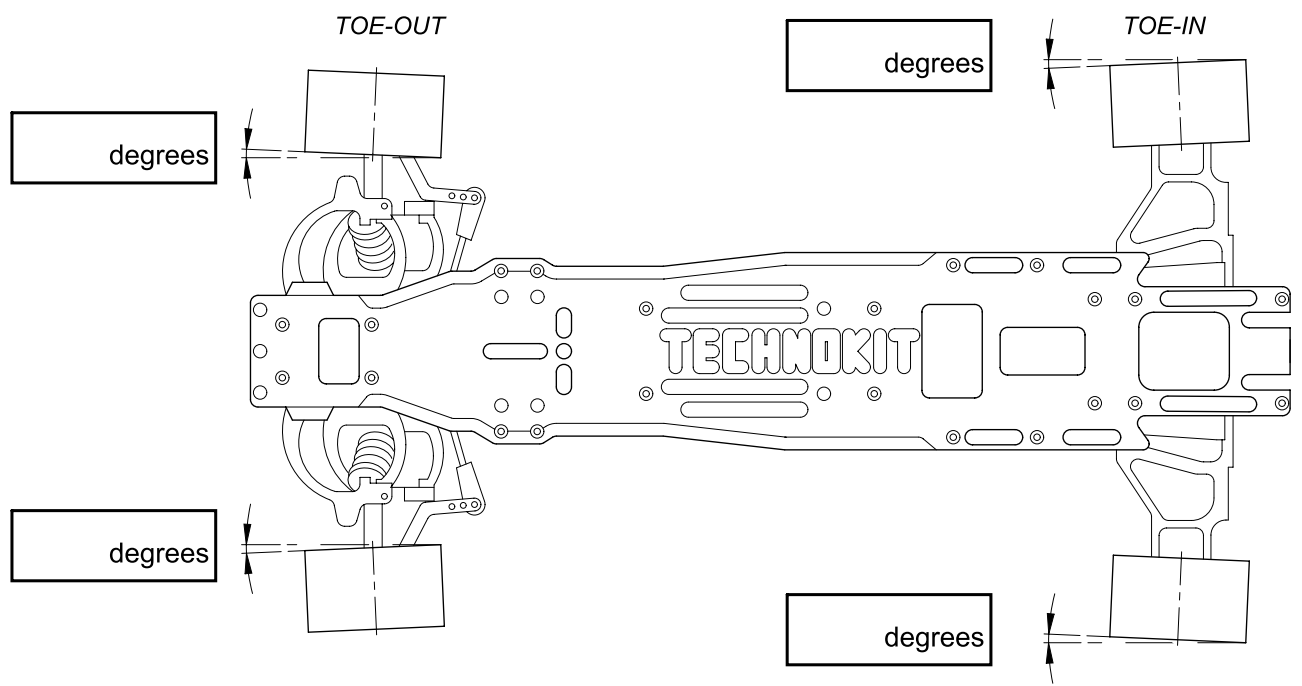



**CAR SET-UP FOR TKT99 E**

**11) DIFFERENTIAL**

**12) DINAMIC FRONT CAMBER**

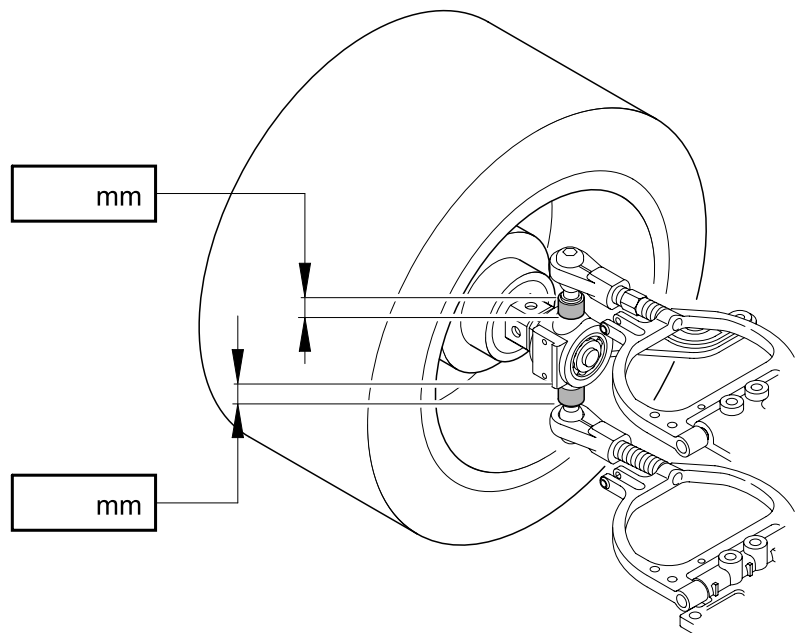
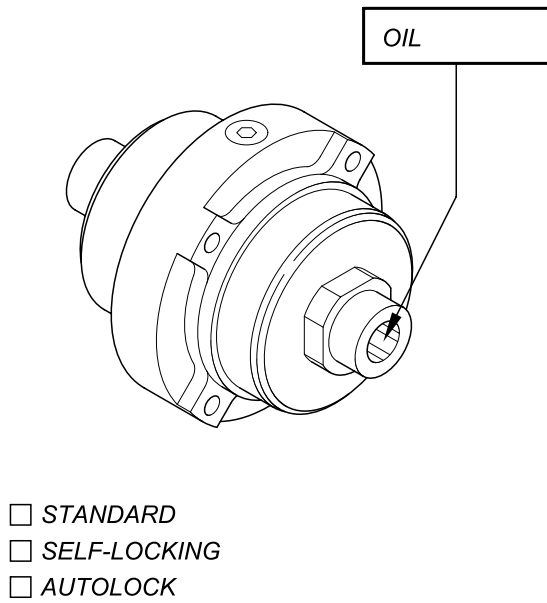

**13) MOTOR-WHEELS GEAR RATIO**

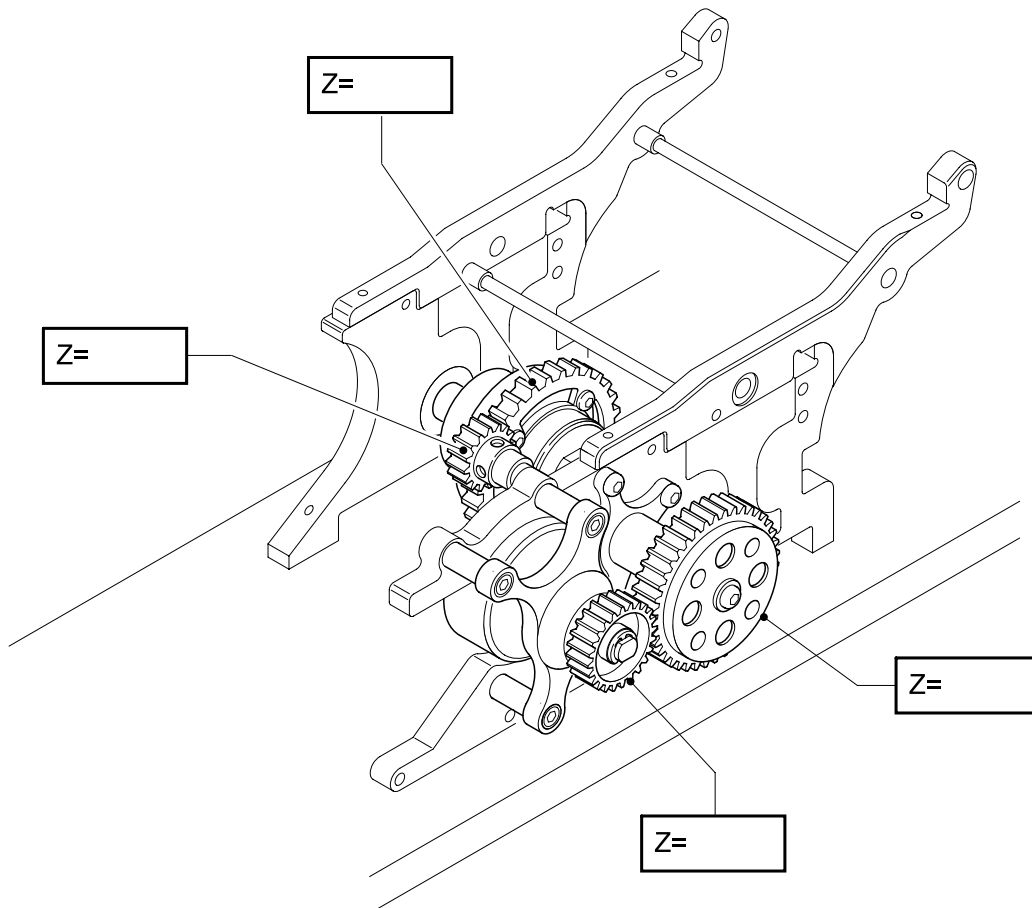



**14) REAR RANGE MAX.**

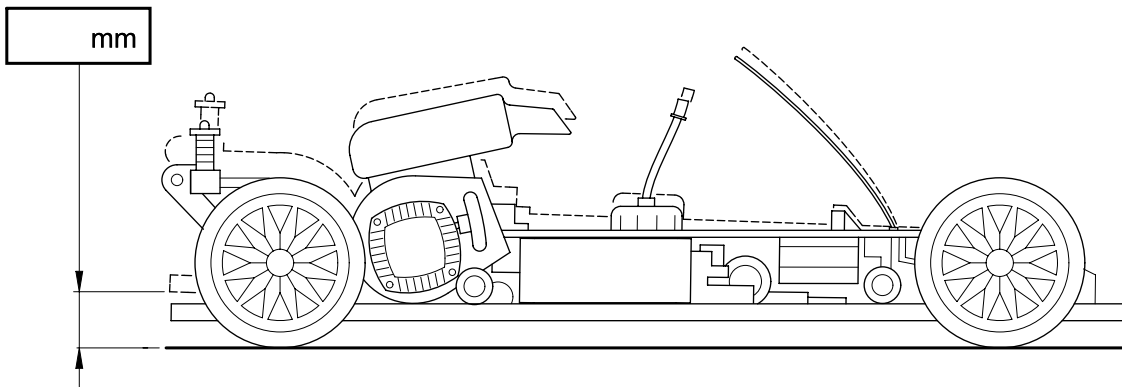

**15) FRONT RANGE MAX.**

